

ELETTROMANDRINI
ELECTROSPINDLES



Componenti ad **alta tecnologia** per produttori di macchine utensili.

--
High-tech components for machine tool manufacturers.

Hiteco è specializzata nella progettazione e realizzazione di componenti elettromeccanici industriali ad alta tecnologia per le macchine utensili.

Elettromandrini A.T.C., elettromandrini M.T.C, teste birotative, teste di foratura ed aggregati.

--
Hiteco is specialized in design and manufacture of high technology industrial electromechanical components for machine tools. **A.T.C. electrospindles, M.T.C. electrospindles, birotary heads, boring units and aggregates.**



Hiteco si propone sul mercato internazionale con un'ampia gamma di prodotti per la lavorazione di: **legno, plastica, materiali avanzati, vetro, pietra e metallo.**

--
Hiteco offers a wide range of products on international market for **wood, plastic, advanced materials, glass, stone and metal processing.**



Hiteco nasce nel 1977 come divisione interna di **SCM Group**, azienda leader mondiale nella costruzione di macchine utensili per la lavorazione di una vasta gamma di materiali, realizzando un percorso di crescita esponenziale. Diventa nel 2008 **un'unità di profitto per servire il mercato terzi**. Oggi realizza prodotti di riferimento nel mercato dei componenti, diventando uno tra i più importanti player mondiali nel settore.

--
Hiteco founded in 1977 as an internal division of the **SCM Group**, leading company in machine tools construction for processing a wide range of materials, had an increasingly exponential growth. In 2008 it become **a profit unit for external customers**. Today Hiteco offers key products for the components market, becoming one of the most important world players in the sector.



Una **presenza capillare** per un **servizio best-in-class e worldwide.**

--
A capillary presence for a **best-in-class** and **worldwide service.**

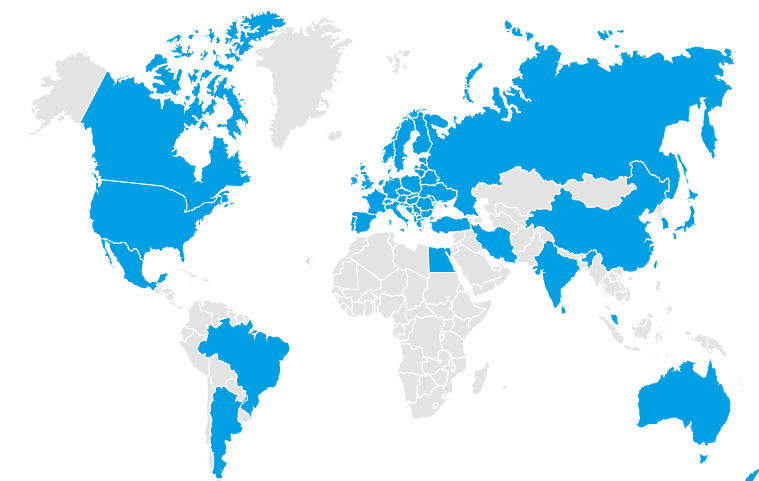

La distribuzione capillare dell'azienda risponde alla volontà di Hiteco di essere vicina al cliente con la presenza sul territorio di **tecnici specializzati** che sono garanzia di una risposta estremamente rapida e professionale: non solo per ridurre fermi macchina e problemi alla produzione, ma anche per creare valore aggiunto con la proposta di soluzioni efficaci ed innovative. Questa attenzione, oltre ai ridotti tempi di consegna, è uno dei motivi che ha portato Hiteco ad avere la più alta **customer satisfaction** nel mercato internazionale.

--
The widespread distribution of the company responds to the desire of Hiteco to be close to the customer with the presence of **specialized technicians** on the territory who guarantee an extremely rapid and professional response: not only to reduce machine downtimes and production problems, but also to create added value with the proposal of effective and innovative solutions. Such care, in addition to reduced delivery times, is one of the reason that led Hiteco to have the highest **customer satisfaction** on the international market.



INDICE INDEX



Hiteco si riserva il diritto di apportare migliorie sulle tecnologie e i modelli presentati nel catalogo
Hiteco reserves the right to make improvements to the technologies and models presented in the catalog

IDENTIFICAZIONE ELETTROMANDRINI / ELECTROSPINDLE IDENTIFICATION KEY

Example **QE 1F 10/TI 24 63F NC CB EN BT OQ IS**

MODELLO (DIMENSIONE CARCASSA) / MODEL (HOUSING DIMENSION)	
QD	102 X 119,5 mm
	110 X 111 mm
QE	130 X 140 mm
QF	150 X 160 mm
QM	215 X 245 mm, 230x230 mm
QX	130 X 130 mm
PX	150 X 150 mm
HX	150 X 150 mm
QT	150 X 150 mm
HT	150 X 150 mm
HD	130 X 130 mm
KX	Ø 202 mm
ML/MA	Ø 158, Ø 166, 135 x 137, 157 x 165
MG	200 X 200 mm
QN	102 X 119,5 mm
MQH1	205 X 175 mm
XS	70 X 65 mm

RAFFREDDAMENTO / COOLING TYPE	
1F= ELETTOVENTOLA/ ELECTROFAN	
1C= ARIA COMPRESSA/ PRESSED AIR	
2= LIQUIDO/LIQUID	
1= VENTOLA SU ALBERO/ FAN ON SHAFT	

POTENZA NOMINALE (S1) @ VELOCITÀ / RATED POWER (S1) @ SPEED
MAX POTENZA @ VELOCITÀ / MAX POWER @ SPEED

VELOCITÀ MAX / MAX SPEED

ATTACCO UTENSILE / TOOL HOLDER
63F = HSK63F
32E = HSK32E
40E = HSK40E
63E = HSK63E
85S = HSK85S
80F = HSK80F
63A = HSK63A
130 = ISO30
140 = ISO40
ER25
ER32
ER40
ALBERO/SHAFT, D=12, 16, 30, 40, 50

NASO MANDRINO / SPINDLE NOSE
NC= NASO CORTO/SHORT NOSE
NL= NASO LUNGO/LONG NOSE
CH = COMPACT SHORT NOSE
LH = COMPACT LONG NOSE

CONNESSIONE ELETTRICA / ELECTRIC CONNECTION
CB= CONNESSIONE BASE/ BASIC CONNECTION
CC= CONNESSIONE CIRCOLARE/ CIRCULAR CONNECTION
PP= CONNESSIONE RAPIDA/ PLUG AND PLAY CONNECTION
SC= SENZA CONNETTORE/ FLYING CABLE

ENCODER
ES= ENCODER 1 VPP (SYNUSOIDAL WAVE)
EN= ENCODER TTL (SQUARE WAVE)

VOLTAGGIO / VOLTAGE
BT= BITENSIONE / DUAL VOLTAGE 220V/380V
220 V

OPTIONAL
OQ=OIL MIST+MQL (Minimal Quantity Lubrication)
AT= AIR TOOL
OM= OIL MIST
CTS= LUBRIFICAZIONE CTS/ COOLANT THROUGH THE SHAFT

ALTRE VARIANTI/ OTHER VARIANTS	
SENSORE DI VIBRAZIONE/ VIBRATION SENSOR	
MONITORAGGIO TEMPERATURA CUSCINETTI/ BEARING TEMPERATURE MONITORING	
MISURATORE DI VELOCITÀ/ SPEED MONITORING	
SS - SENSORE RITORNO PISTONE/ PISTON BACK SENSOR	
SENSORE DI TEMPERATURA/ TEMPERATURE SENSOR	
iSPINDLE - DIGITAL COMMUNICATION ON FIELDBUS/ COMUNICAZIONE DIGITALE SENSORI SU FIELDBUS	

INDICE POTENZE / POWER INDEX

POWERTECH	POWERTECH 200	POWERTECH 250	POWERTECH 300 COMPACT	POWERTECH 300	POWERTECH 400 HS	POWERTECH 400	POWERTECH 500	POWERTECH 600
POWER @RPM - MAX SPEED								
4/12 24	p. 9		p. 15					
5.5/6 20 (HT)						p. 23		
5.5/12 24			p. 15	p. 17				
6.5/12 36 (HS)		p. 11						
6.5/12 40 (HS)		p. 12						
6.6/12 24				p. 17				
7.5/6 24 (HT)						p. 23		
8/9 18 (HT)							p. 31	
8/12 24				p. 18 - 19				
8/12 28 (HS)					p. 21			
8/12 36 (HS)		p. 11						
8/12 40 (HS)		p. 12						
8.5/6 24 (HT)						p. 24		
8.5/12 24						p. 25		
9/6 24 (HT)						p. 27		
9.5/12 24				p. 19				
10/11 24						p. 25		
11/6 10 (HT)								p. 35
11/6 24 (HT)						p. 27		
11/12 20							p. 32	
12/6 18 (HT)							p. 33	
12/12 24						p. 26		
13/7 15 (HT)							p. 31	
13/12 24						p. 28		
16/12 24						p. 28		
18/6 12 (HT)								p. 35
18/12 20							p. 33	

HS= HIGH SPEED
HT= HIGH TORQUE

INDICE POTENZE / POWER INDEX

ROBOTECH	ROBOTECH QX	ROBOTECH QX HS	ROBOTECH PX-HX	ROBOTECH HX 3C	ROBOTECH HD	ROBOTECH QT	ROBOTECH HT	ROBOTECH QM
5.6/18 20					p. 51			
8/15 36 (HS)		p. 41						
8/15 40 (HS)		p. 41						
8.5/12 24	p. 37							
10/7 24 (HT)			p. 43	p. 47				
10/12 24	p. 37							
11/12 24	p. 38							
12/12 24			p. 43	p. 47				
13/6 16 (HT)						p. 53		
15/12 24			p. 44	p. 48				
18/12 24			p. 44	p. 48				
20/10 24			p. 45	p. 49				
25/7 16 (HT)						p. 53		
25/10 24							p. 55	
30/6 13 (HT)								p. 57

CUSTOMTECH	CUSTOMTECH KX	CUSTOMTECH MG
9/6 15		p. 61
13.5/6 15		p. 61
30/7.5 12		p. 62
31/3 15	p. 59	
32/4.5 24	p. 59	

MULTITECH	MULTITECH MA	MULTITECH ML	MULTITECH XS	MULTITECH S	MULTITECH QN	MULTITECH MQH
0.19/12 12				p. 79		
0.35/12 12			p. 75			
0.55/12 12			p. 76			
0.65/12 12			p. 77			
1.5/12 12				p. 80		
1.8/12 12				p. 81		
4/14 24						
4.5/18 18					p. 83	
4.5/18 24					p. 83	
6/18 18					p. 84	
6/18 24					p. 84	
7.5/12 24	p. 65	p. 67 - 69				
8/6 9						p. 87
9.5/12 24		p. 71 - 73				
10/12 24		p. 67 - 69				
13/6 9						p. 87

ADDITIONAL EQUIPMENT	
C-AXIS FOR POWERTECH 300-400	p. 88
REFERENCE SLEEVE	p. 88
TOOL HOLDER	p. 89
TOOL FINGER	p. 89
HEAT EXCHANGER	p. 89

POWERTECH 200



SUITABLE FOR MACHINING WOOD, PLASTICS AND COMPOSITES
 REDUCED SPACE REQUIRED AND FIXING FLEXIBILITY (AVAILABLE ON 2 SIDES)
 AVAILABLE WITH ISO 30, HSK 63F AND DUAL VOLTAGE
 CERAMIC BEARINGS
 EASY MAINTENANCE

QD-1F 4/12 24

PRESTAZIONI / PERFORMANCES

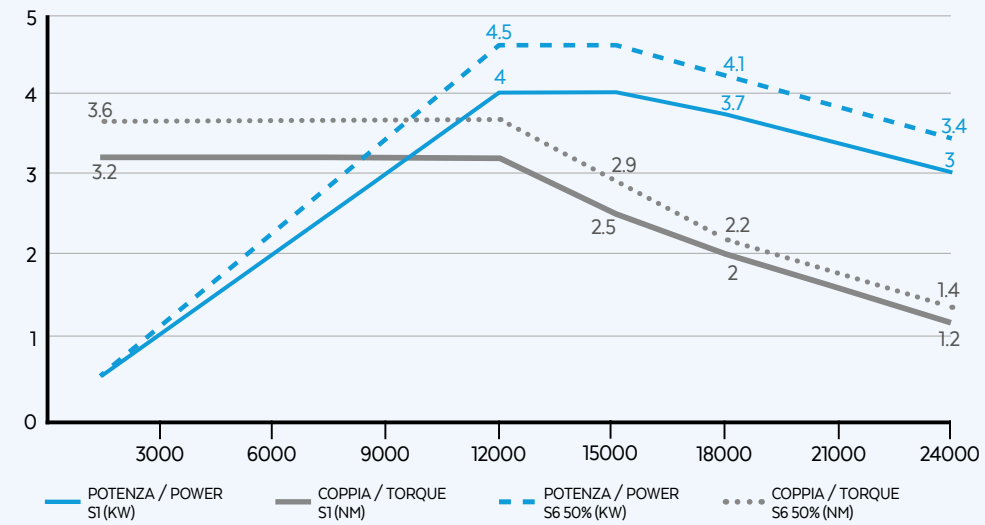

OPZIONALI / OPTIONALS

- Circular connector CC
- HSK 63F
- Plug & Play
- COM-PRESSED AIR
- Bearings temperature monitoring
- Speed monitoring
- Vibration sensor
- Pressed air cooling

SPECIFICHE TECNICHE / TECHNICAL SPECIFICATIONS

- S1-S6 kW 4/4.5
- S1-S6 A 9/10.7
- Pol es 4
- S1-S6 Nm 3.2/3.6
- Volt 380
- Supply inverter
- rpm 24000
- kg 18
- Dual voltage 220V-380V

EQUIPAGGIAMENTO / EQUIPMENT

- ISO 30
- Electrofan cooling
- Double effect pneumatic cylinder
- Automatic tool changer
- Ceramic ball bearings
- Grease lubrication
- Sensors s1, s2, s3
- Taper cleaning
- Labyrinth with air seal

LAYOUT HSK 63F CB

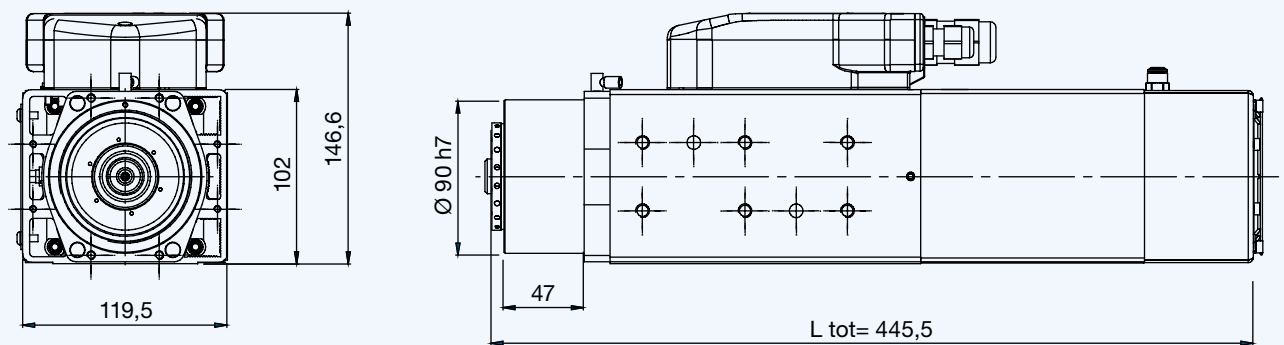

ALTRI LAYOUT / OTHER LAYOUTS

	ΔL	L tot
ISO 30	+6,9 mm	452,40 mm
Aria compressa / Air compressed	ISO30= -29,1 mm	416,4 mm
	HSK63F= -36,0 mm	409,5 mm



POWERTECH 250



SUITABLE FOR MACHINING ALUMINUM, PLASTICS AND LIGHT ALLOYS
 VERY STRONG SPINDLES WITH SPEEDS UP TO 40K RPM
 5 BEARINGS FOR HIGH STIFFNESS
 SUITABLE FOR 3 AND 5-AXIS MACHINES

LAYOUT HSK40E / HSK32E CC

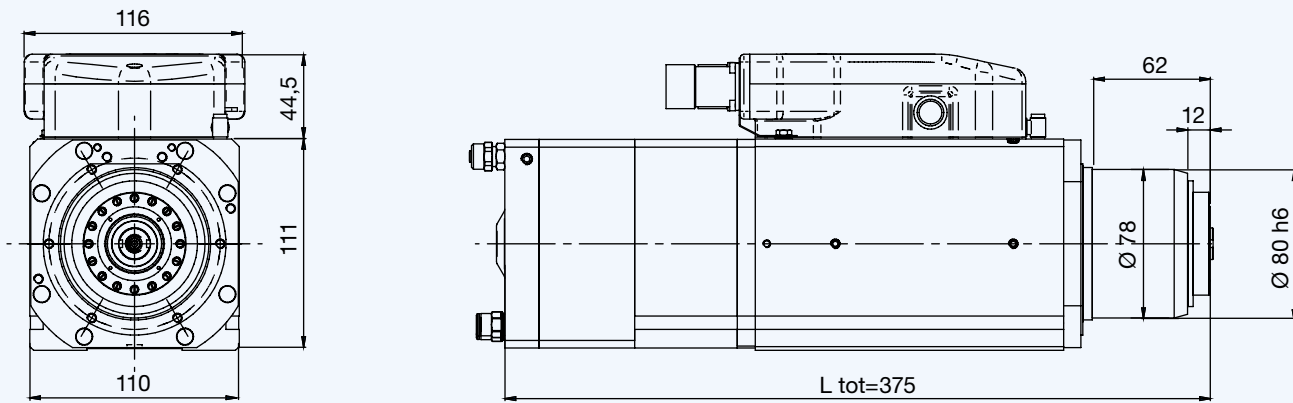

LAYOUT HSK40E / HSK32E SC

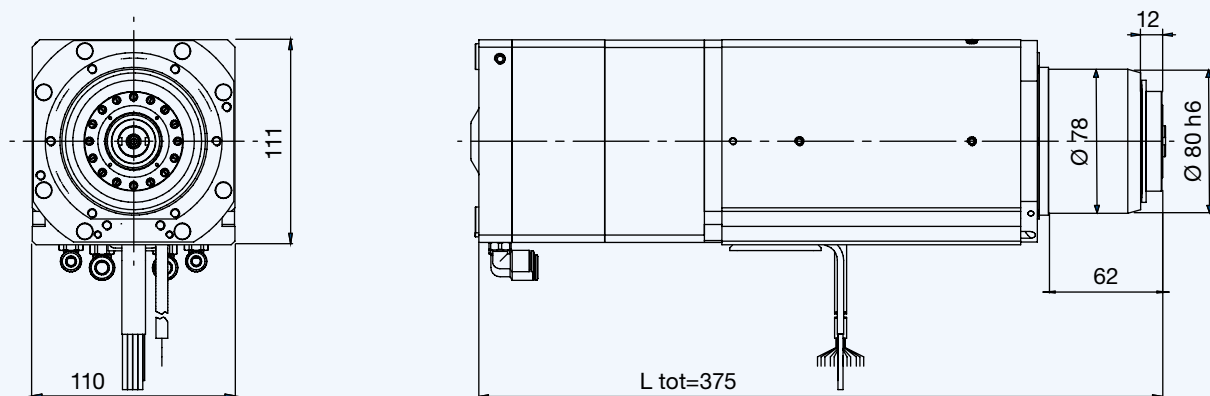

QD-2 6.5/12 36

HIGH SPEED

PRESTAZIONI / PERFORMANCES

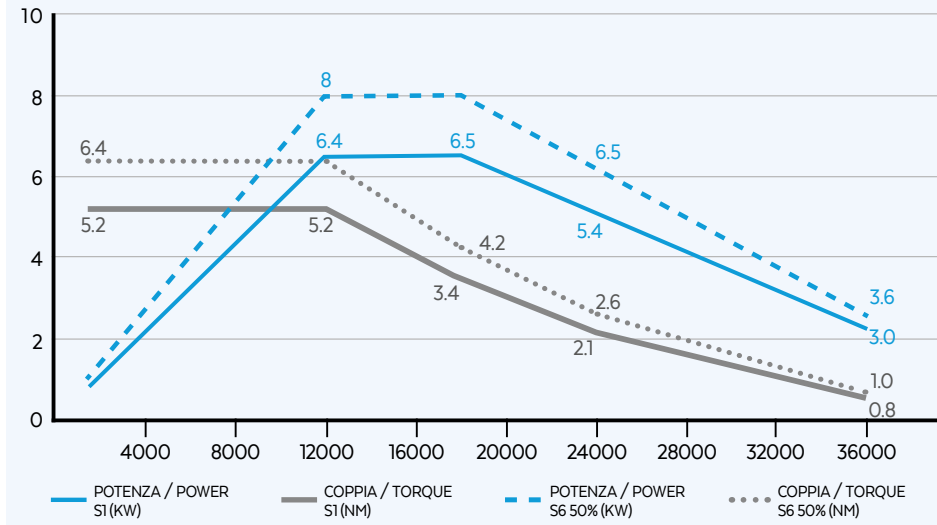

OPZIONALI / OPTIONALS

- Encoder TVpp or TTL
- Quick connection PP
- HSK 32E
- Circular connector cc machine side
- Bearings temperature monitoring
- Speed monitoring
- Vibration sensor
- Temperature sensor

SPECIFICHE TECNICHE / TECHNICAL SPECIFICATIONS

- S1-S6 kW 6.5/8
- S1-S6 Nm 5.2/6.4
- S1-S6 rpm 36000
- S1-S6 A 20.5/23
- Volt 380
- kg 17
- 4 Poles
- inverter Supply

EQUIPAGGIAMENTO / EQUIPMENT

- HSK 40E
- Ceramic ball bearings
- Circular connector spindle side
- Liquid cooling
- Labyrinth with air seal
- Taper cleaning

- Double effect pneumatic cylinder
- Grease lubrication
- Automatic tool changer
- Sensors s1, s2, s3, s5

QD-2 8/12 36

HIGH SPEED

PRESTAZIONI / PERFORMANCES

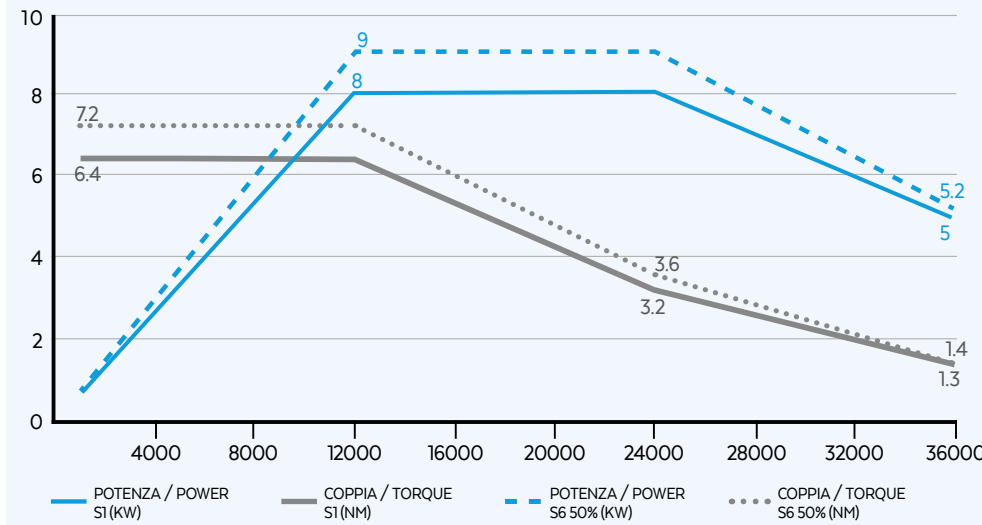

OPZIONALI / OPTIONALS

- Encoder TVpp or TTL
- Quick connection PP
- HSK 32E
- Circular connector cc machine side
- Bearings temperature monitoring
- Speed monitoring
- Vibration sensor
- Temperature sensor

SPECIFICHE TECNICHE / TECHNICAL SPECIFICATIONS

- S1-S6 kW 8/9
- S1-S6 Nm 6.4/7.2
- S1-S6 rpm 36000
- S1-S6 A 24/26
- Volt 380
- kg 17
- 4 Poles
- inverter Supply

EQUIPAGGIAMENTO / EQUIPMENT

- HSK 40E
- Ceramic ball bearings
- Circular connector spindle side
- Liquid cooling
- Labyrinth with air seal
- Taper cleaning

- Double effect pneumatic cylinder
- Grease lubrication
- Automatic tool changer
- Sensors s1, s2, s3, s5

PRESTAZIONI / PERFORMANCES

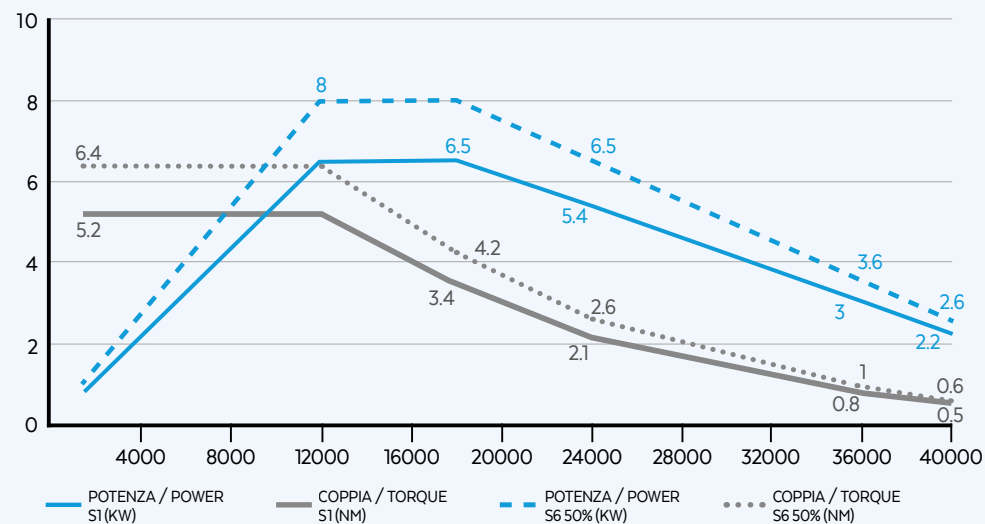

OPZIONALI / OPTIONALS

- Encoder TVpp or TTL
- Quick connection PP
- Vibration sensor
- Temperature sensor
- Bearings temperature monitoring
- Speed monitoring
- Circular connector cc machine side

SPECIFICHE TECNICHE / TECHNICAL SPECIFICATIONS

- Power: 6.5/8 kW
- Current: 20.5/23 A
- Pol es: 4
- Power: 5.2/6.4 Nm
- Voltage: 380 Volt
- Supply: inverter
- Speed: 40000 rpm
- Weight: 17 kg

EQUIPAGGIAMENTO / EQUIPMENT

- HSK 32E
- Liquid cooling
- Double effect pneumatic cylinder
- Automatic tool changer
- Ceramic ball bearings
- Labyrinth with air seal
- Grease lubrication
- Sensors s1, s2, s3, s5
- Circular connector spindle side
- Taper cleaning

PRESTAZIONI / PERFORMANCES

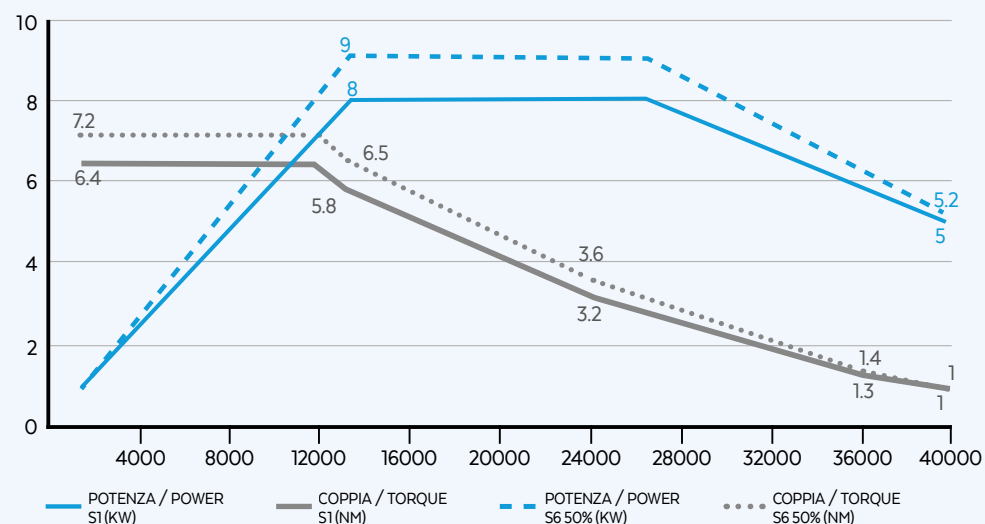

OPZIONALI / OPTIONALS

- Encoder TVpp or TTL
- Quick connection PP
- Vibration sensor
- Temperature sensor
- Bearings temperature monitoring
- Speed monitoring
- Circular connector cc machine side

SPECIFICHE TECNICHE / TECHNICAL SPECIFICATIONS

- Power: 8/9 kW
- Current: 24/26 A
- Pol es: 4
- Power: 6.4/7.2 Nm
- Voltage: 380 Volt
- Supply: inverter
- Speed: 40000 rpm
- Weight: 17 kg

EQUIPAGGIAMENTO / EQUIPMENT

- HSK 32E
- Liquid cooling
- Double effect pneumatic cylinder
- Automatic tool changer
- Ceramic ball bearings
- Labyrinth with air seal
- Grease lubrication
- Sensors s1, s2, s3, s5
- Circular connector spindle side
- Taper cleaning

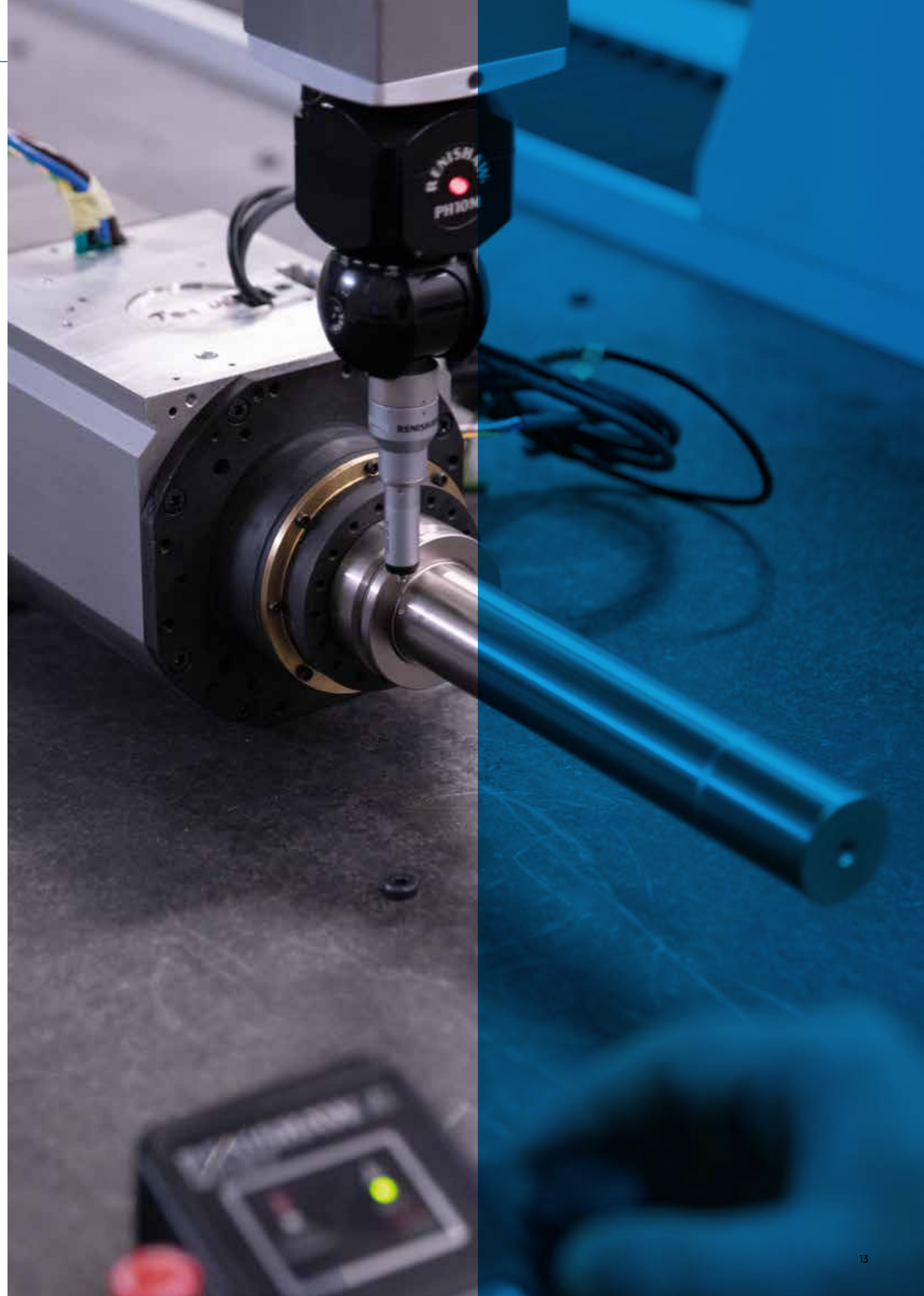

POWERTECH 300 COMPACT



SUITABLE FOR MACHINING WOOD, ALUMINUM AND PLASTICS
REDUCED SPACE REQUIRED
AVAILABLE WITH ISO 30, HSK 63F AND DUAL VOLTAGE
CERAMIC BEARINGS

LAYOUT ISO30 CB

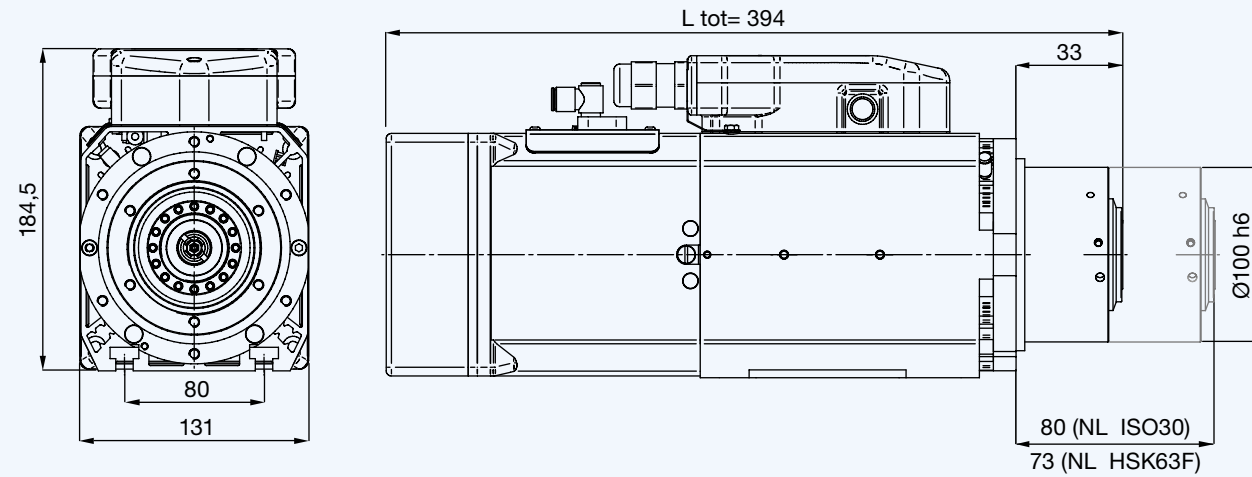

ALTRI LAYOUT / OTHER LAYOUTS

	ΔL	L tot
Aria compressa / Air compressed	ISO30= -30 mm	360 mm
	HSK63F= -30 mm	360 mm

QE-1F 4 12/24

PRESTAZIONI / PERFORMANCES

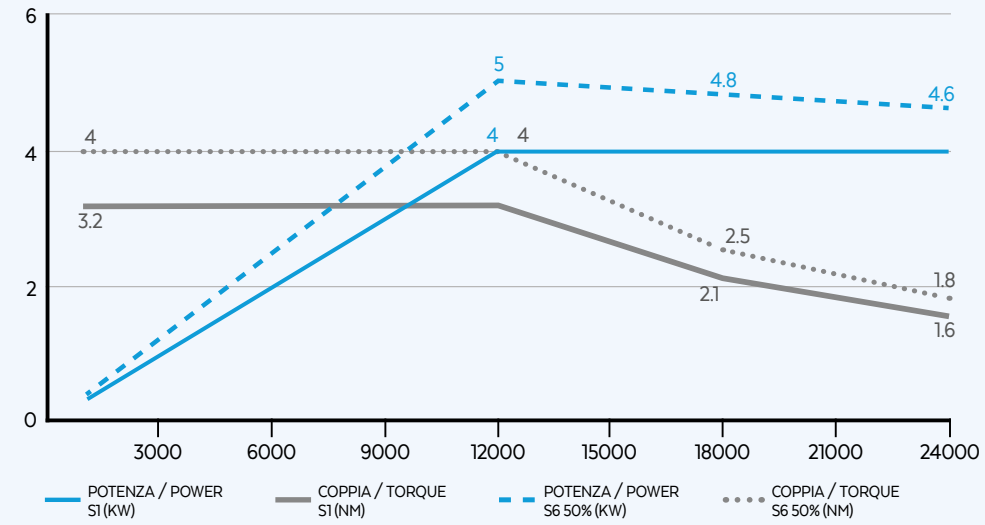

OPZIONALI / OPTIONALS

- Encoder TVpp or TTL
- Bearings temperature monitoring
- Circular connector CC
- Speed monitoring
- Plug & Play Quick connection PP
- Vibration sensor
- Sensor s5
- HSK 63F
- COM-PRESSED AIR Pressed air cooling

SPECIFICHE TECNICHE / TECHNICAL SPECIFICATIONS

- S1-S6 kW 4/5
- S1-S6 A 8.5/10
- Pol es 2
- S1-S6 Nm 3.2/4
- Volt 380
- Supply inverter
- rpm 24000
- kg 19
- Dual voltage 220V-380V

EQUIPAGGIAMENTO / EQUIPMENT

- ISO 30
- Electrofan cooling
- Single effect pneumatic cylinder
- Automatic tool changer
- Ceramic ball bearings
- Labyrinth with air seal
- Sensors s1, s2, s3
- Taper cleaning
- Grease lubrication

QE-1F 5.5 12/24

PRESTAZIONI / PERFORMANCES

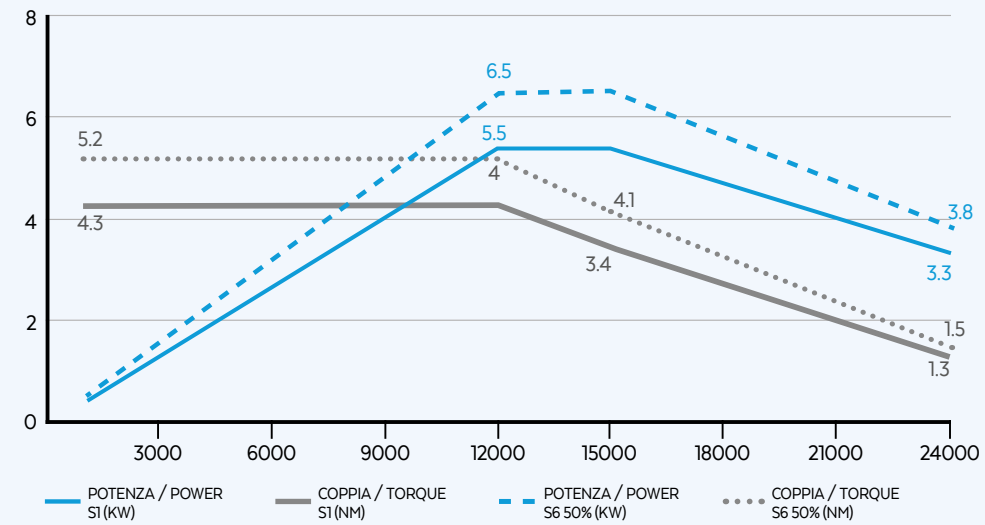

OPZIONALI / OPTIONALS

- Encoder TVpp or TTL
- Bearings temperature monitoring
- Circular connector CC
- Speed monitoring
- Plug & Play Quick connection PP
- Vibration sensor
- Sensor s5
- HSK 63F
- COM-PRESSED AIR Pressed air cooling

SPECIFICHE TECNICHE / TECHNICAL SPECIFICATIONS

- S1-S6 kW 5.5/6.5
- S1-S6 A 11/13
- Pol es 4
- S1-S6 Nm 4/4.3
- Volt 380
- Supply inverter
- rpm 24000
- kg 19
- Dual voltage 220V-380V

EQUIPAGGIAMENTO / EQUIPMENT

- ISO 30
- Electrofan cooling
- Single effect pneumatic cylinder
- Automatic tool changer
- Ceramic ball bearings
- Labyrinth with air seal
- Sensors s1, s2, s3
- Taper cleaning
- Grease lubrication

POWERTECH 300



SUITABLE FOR MACHINING WOOD, PLASTICS AND COMPOSITES
WIDE RANGE OF POWER FOR ANY TYPE OF MACHINING
AVAILABLE WITH LIQUID COOLING FOR HEAVY AND INTENSIVE PROCESSES
EASY MAINTENANCE

LAYOUT HSK 63F CB

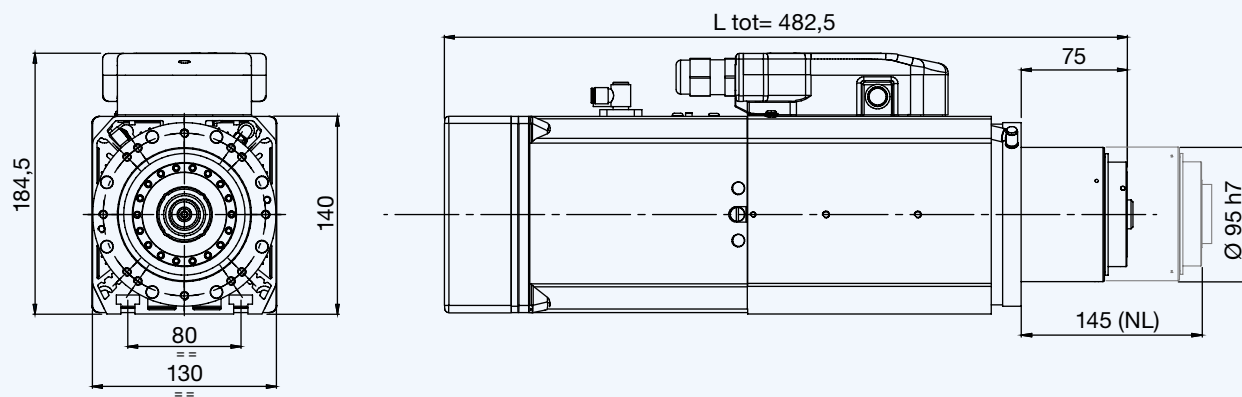

ALTRI LAYOUT / OTHER LAYOUTS

	ΔL	L _{tot}
ISO 30	+6,9 mm	489,4 mm
Aria compressa / Air compressed	ISO30= -44 mm	438,5 mm
	HSK63F= -44 mm	438,5 mm
Encoder (1 Vpp or TTL)	ISO30= +7 mm	496,4 mm
	HSK= +7 mm	489,5 mm

QE-1F 5.5/12 24

PRESTAZIONI / PERFORMANCES

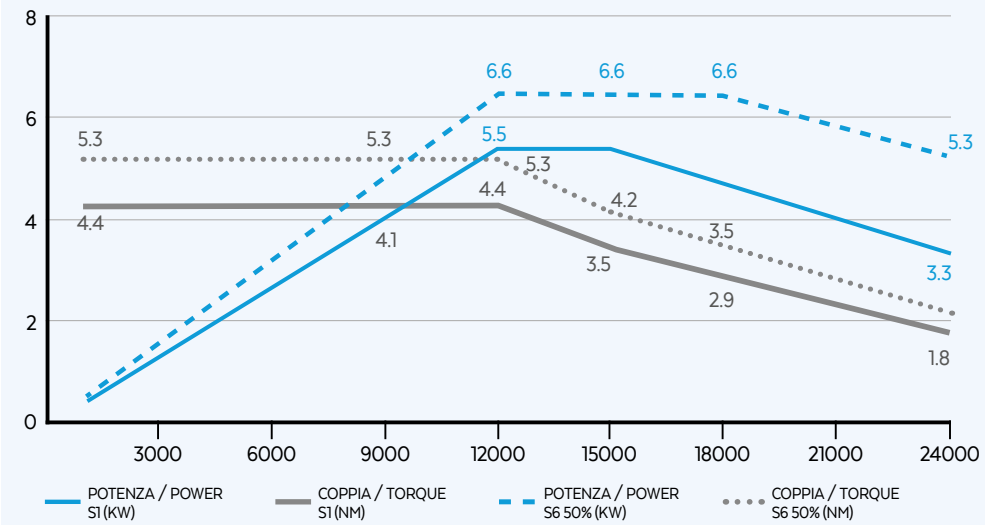

OPZIONALI / OPTIONALS

- Encoder TVpp or TTL
- Circular connector CC
- Quick connection PP
- Long nose
- Air tool
- ISO 30
- Bearings temperature monitoring
- Speed monitoring
- Vibration sensor
- C-AXES available
- Sensor s5
- Pressed air cooling

SPECIFICHE TECNICHE / TECHNICAL SPECIFICATIONS

- S1-S6 kW 5.5/6.6
- S1-S6 Nm 4.4/5.3
- rpm 24000
- S1-S6 A 13.5/14.5
- Volt 380
- kg 21
- Pol es 4
- Supply inverter

EQUIPAGGIAMENTO / EQUIPMENT

- HSK 63F
- Ceramic ball bearings
- Taper cleaning
- Electrofan cooling
- Labyrinth with air seal
- Grease lubrication
- Double effect pneumatic cylinder
- Sensors s1, s2, s3
- Automatic tool changer

QE-1F 6.6/12 24

PRESTAZIONI / PERFORMANCES

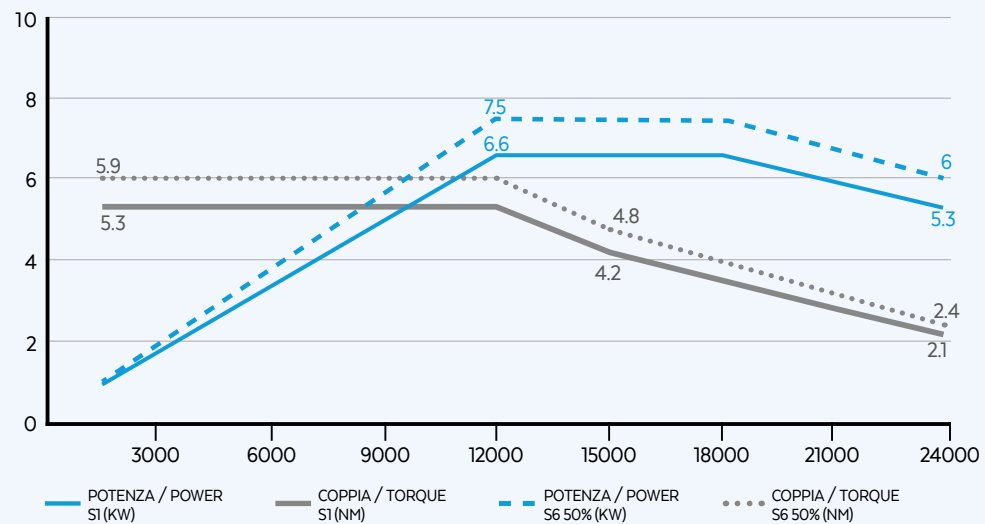

OPZIONALI / OPTIONALS

- Encoder TVpp or TTL
- Circular connector CC
- Quick connection PP
- Long nose
- Air tool
- ISO 30
- Bearings temperature monitoring
- Speed monitoring
- Vibration sensor
- C-AXES available
- Sensor s5
- Pressed air cooling

SPECIFICHE TECNICHE / TECHNICAL SPECIFICATIONS

- S1-S6 kW 6.6/7.5
- S1-S6 Nm 5.3/5.9
- rpm 24000
- S1-S6 A 14.5/16
- Volt 380
- kg 21
- Pol es 4
- Supply inverter
- Dual voltage 220V-380V

EQUIPAGGIAMENTO / EQUIPMENT

- HSK 63F
- Ceramic ball bearings
- Taper cleaning
- Electrofan cooling
- Grease lubrication
- Double effect pneumatic cylinder
- Labyrinth with air seal
- Sensors s1, s2, s3
- Automatic tool changer

QE-1F 8/12 24

PRESTAZIONI / PERFORMANCES

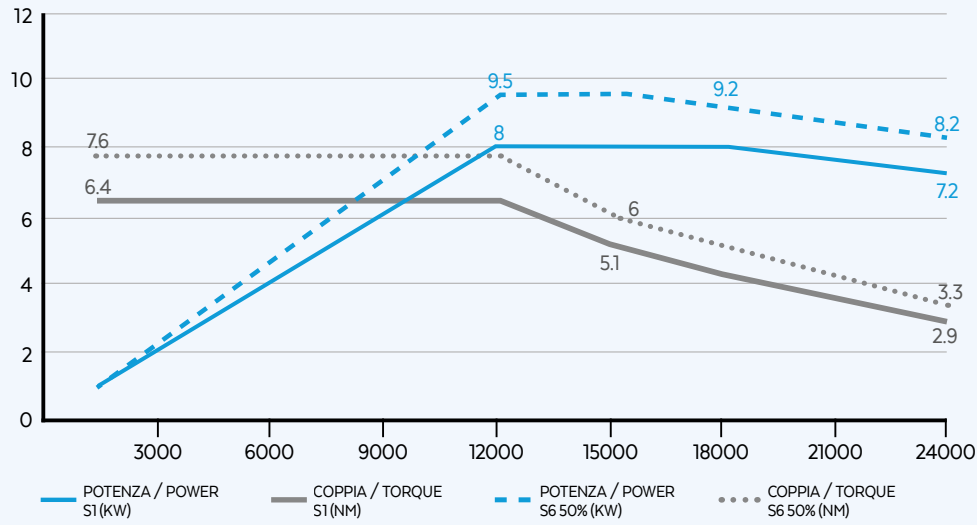

OPZIONALI / OPTIONALS

- Circular connector CC
- Quick connection PP
- Long nose
- Air tool
- Sensor s5
- ISO 30
- Bearings temperature monitoring
- Speed monitoring
- Vibration sensor
- C-axes available
- Encoder 1Vpp or TTL
- Pressed air cooling

SPECIFICHE TECNICHE / TECHNICAL SPECIFICATIONS

- 8/9.5
- 18.5/20.5
- 4
- inverter
- Dual voltage 220V-380V
- 6.4/7.6
- 380
- 24000
- 21

EQUIPAGGIAMENTO / EQUIPMENT

- HSK 63F
- Electrofan cooling
- Double effect pneumatic cylinder
- Automatic tool changer
- Ceramic ball bearings
- Labyrinth with air seal
- Sensors s1, s2, s3
- Taper cleaning
- Grease lubrication

LAYOUT ISO 30 PP

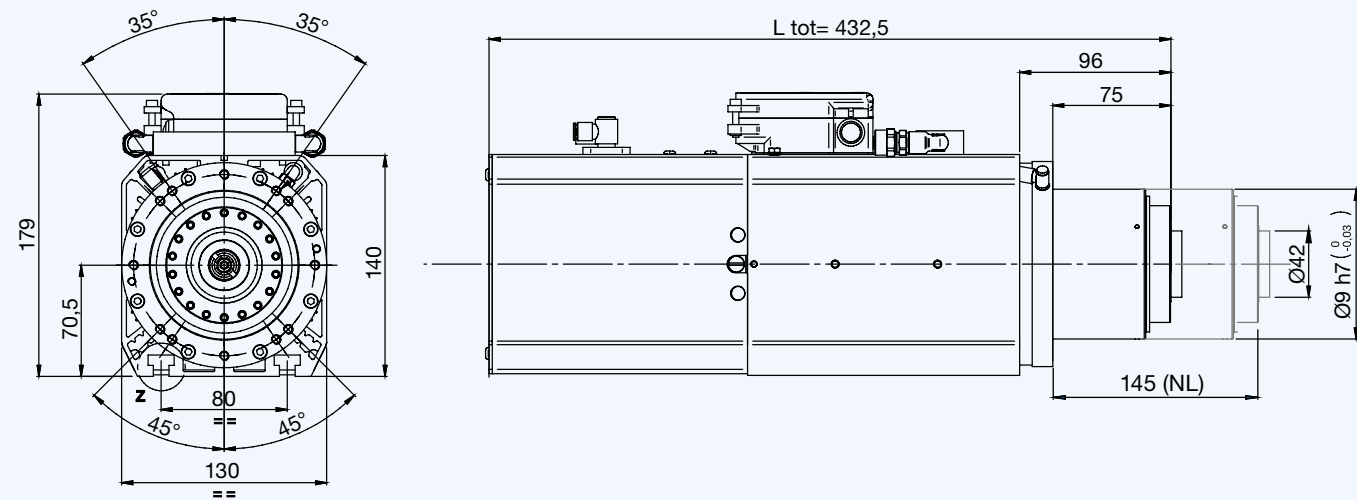

ALTRI LAYOUT / OTHER LAYOUTS

	ΔL	L tot
Encoder (1 Vpp or TTL)	ISO30= +7 mm	439,5 mm
	HSK 63F= +7 mm	432,5 mm

QE-2 8/12 24

LIQUID

PRESTAZIONI / PERFORMANCES

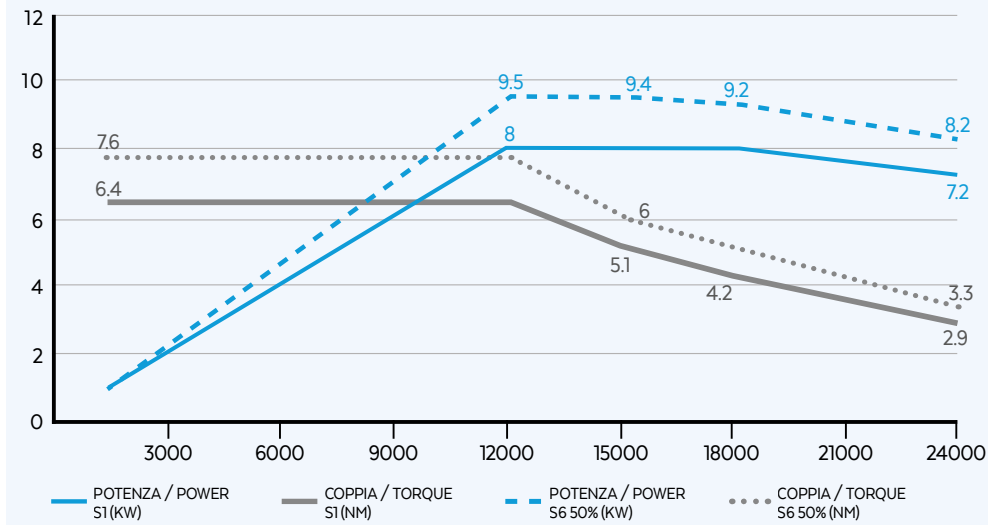

OPZIONALI / OPTIONALS

- Encoder 1Vpp or TTL
- Long nose
- Air tool
- Quick connection pp machine side
- Sensor s5
- Bearings temperature monitoring
- Speed monitoring
- Vibration sensor
- C-axes available
- HSK 63F

SPECIFICHE TECNICHE / TECHNICAL SPECIFICATIONS

- 8/9.5
- 18.5/20.5
- 4
- inverter
- 6.4/7.6
- 380
- 24000
- 21

EQUIPAGGIAMENTO / EQUIPMENT

- ISO 30
- Liquid cooling
- Double effect pneumatic cylinder
- Automatic tool changer
- Ceramic ball bearings
- Labyrinth with air seal
- Sensors s1, s2, s3
- Grease lubrication
- Taper cleaning
- Quick connection pp spindle side

QE-2 9,5/12 24

LIQUID

PRESTAZIONI / PERFORMANCES

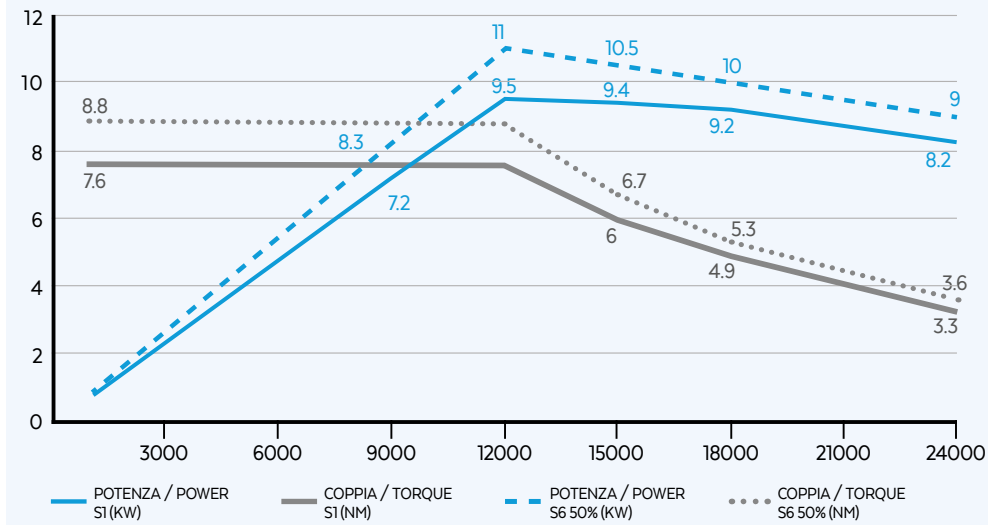

OPZIONALI / OPTIONALS

- Encoder 1Vpp or TTL
- Long nose
- Air tool
- Quick connection pp machine side
- Sensor s5
- Bearings temperature monitoring
- Speed monitoring
- Vibration sensor
- C-axes available
- HSK 63F

SPECIFICHE TECNICHE / TECHNICAL SPECIFICATIONS

- 9.5/11
- 20.5/23
- 4
- inverter
- 7.6/8.8
- 380
- 24000
- 21

EQUIPAGGIAMENTO / EQUIPMENT

- ISO 30
- Liquid cooling
- Double effect pneumatic cylinder
- Automatic tool changer
- Ceramic ball bearings
- Labyrinth with air seal
- Sensors s1, s2, s3
- Grease lubrication
- Taper cleaning
- Quick connection pp spindle side

POWERTECH 400 HIGH SPEED



SUITABLE FOR MACHINING ALUMINUM AND COMPOSITES
LONG NOSE DESIGN TO GUARANTEE STRONG RIGIDITY
AIR COOLED SPINDLES WITH HIGH SPEED UP TO 28K RPM FOR FASTER FEED RATES
AVAILABLE WITH ISO 30, HSK 63F AND DUAL VOLTAGE

QE-1F 8/12 28

HIGH SPEED

PRESTAZIONI / PERFORMANCES

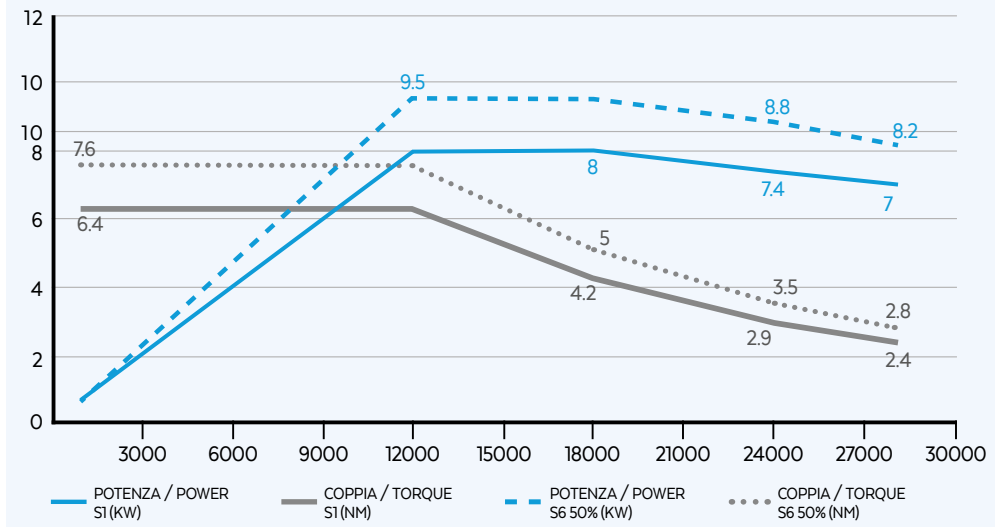

OPZIONALI / OPTIONALS

- Encoder 1Vpp or TTL
- ISO 30
- Air tool
- Plug & Play
- Sensors s5
- Bearings temperature monitoring
- Speed monitoring
- Vibration sensor
- C-AXES available
- Circular connector machine side

SPECIFICHE TECNICHE / TECHNICAL SPECIFICATIONS

- S1-S6 kW 8/9
- S1-S6 A 17/19
- Pol es 4
- S1-S6 Nm 6.4/7.6
- Volt 380
- Supply inverter
- rpm 28000
- kg 25
- Dual voltage 220V-380V

EQUIPAGGIAMENTO / EQUIPMENT

- HSK 63F
- Ceramic ball bearings
- Circular connector spindle side
- Electrofan cooling
- Labyrinth with air seal
- Taper cleaning
- Double effect pneumatic cylinder
- Sensors s1, s2, s3
- Automatic tool changer
- Grease lubrication

LAYOUT HSK 63F CC

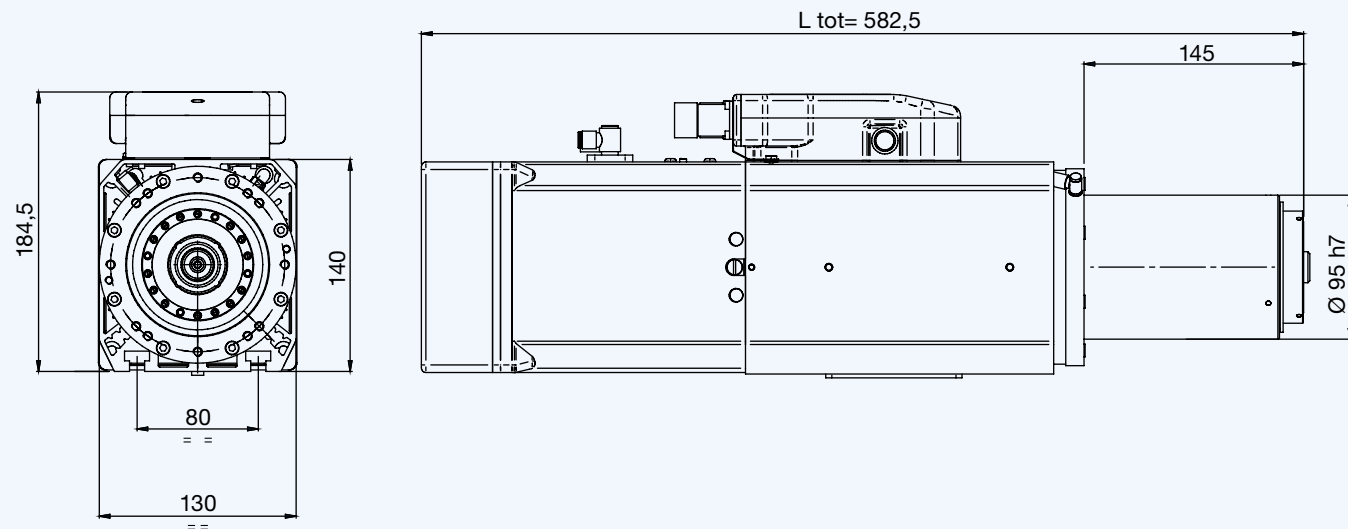

ALTRI LAYOUT / OTHER LAYOUTS

	ΔL	L tot
ISO 30	+6,9 mm	589,4 mm
Encoder (1 Vpp or TTL)	+7 mm	589,5 mm



POWERTECH 400



SUITABLE FOR MACHINING WOOD AND ALUMINUM
WIDE RANGE OF POWER UP TO 16 KW. HIGH TORQUE VERSIONS AVAILABLE
AVAILABLE WITH LIQUID COOLING FOR HEAVY AND INTENSIVE PROCESSES
EASY MAINTENANCE

LAYOUT HSK 63F CB

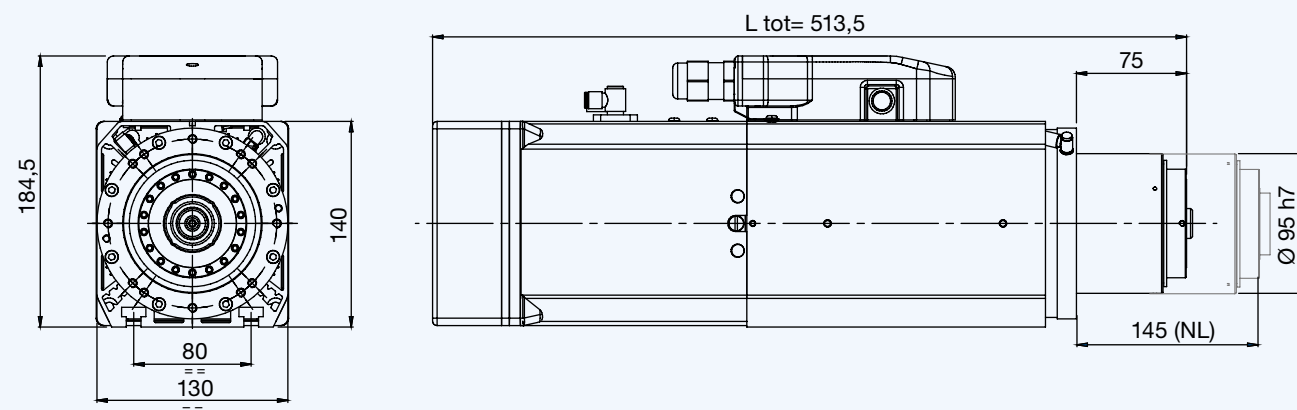

ALTRI LAYOUT / OTHER LAYOUTS

	ΔL	L tot
ISO 30	+6,9 mm	520,6 mm
Aria compressa / Air compressed	ISO30= -44 mm	469,5 mm
	HSK63F= -44 mm	469,5 mm
Encoder (1 Vpp or TTL)	+7 mm	520,5 mm
	+7 mm	470,5 mm

QE-1F 5.5/6 20

HIGH TORQUE

PRESTAZIONI / PERFORMANCES

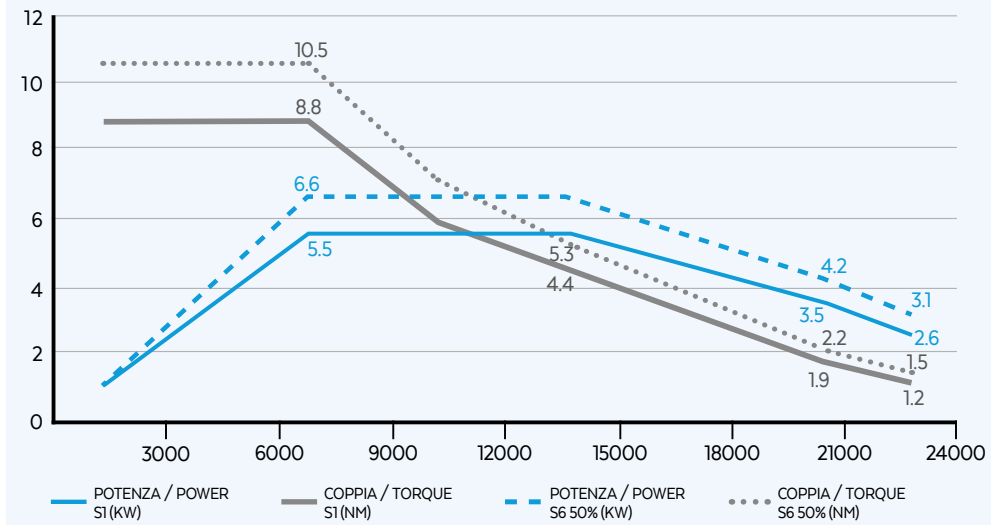

OPZIONALI / OPTIONALS

- Encoder TVpp or TTL
- Circular connector CC
- Quick connection PP
- Air tool
- Long nose
- ISO 30
- Bearings temperature monitoring
- Speed monitoring
- Vibration sensor
- C-AXES available
- Sensor s5
- Pressed air cooling

SPECIFICHE TECNICHE / TECHNICAL SPECIFICATIONS

- S1-S6 kW 5.5/6.6
- S1-S6 Nm 8.8/10.5
- rpm 20000
- S1-S6 A 12/13
- Volt 380
- kg 24
- Pol es 4
- Supply inverter

EQUIPAGGIAMENTO / EQUIPMENT

- HSK 63F
- Ceramic ball bearings
- Taper cleaning
- Electrofan cooling
- Labyrinth with air seal
- Double effect pneumatic cylinder
- Sensors s1, s2, s3
- Automatic tool changer
- Grease lubrication

QE-1F 7.5/6 24

HIGH TORQUE

PRESTAZIONI / PERFORMANCES

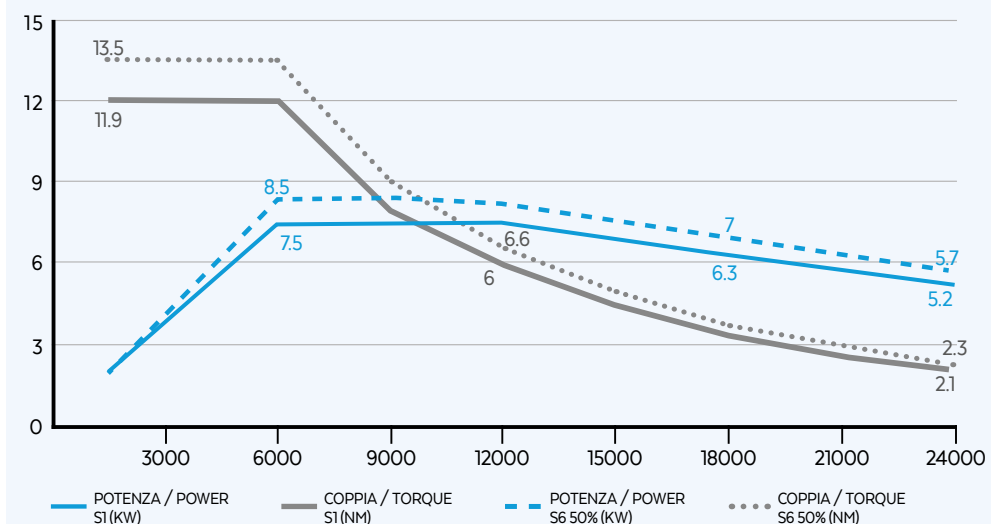

OPZIONALI / OPTIONALS

- Encoder TVpp or TTL
- Circular connector CC
- Quick connection PP
- Air tool
- Long nose
- ISO 30
- Bearings temperature monitoring
- Speed monitoring
- Vibration sensor
- C-AXES available
- Sensor s5

SPECIFICHE TECNICHE / TECHNICAL SPECIFICATIONS

- S1-S6 kW 7.5/8.5
- S1-S6 Nm 11.9/13.5
- rpm 24000
- S1-S6 A 19.5/21.5
- Volt 380
- kg 24
- Pol es 4
- Supply inverter

EQUIPAGGIAMENTO / EQUIPMENT

- HSK 63F
- Ceramic ball bearings
- Taper cleaning
- Electrofan cooling
- Labyrinth with air seal
- Double effect pneumatic cylinder
- Sensors s1, s2, s3
- Automatic tool changer
- Grease lubrication

QE-1F 8.5/6 24

HIGH TORQUE

PRESTAZIONI / PERFORMANCES

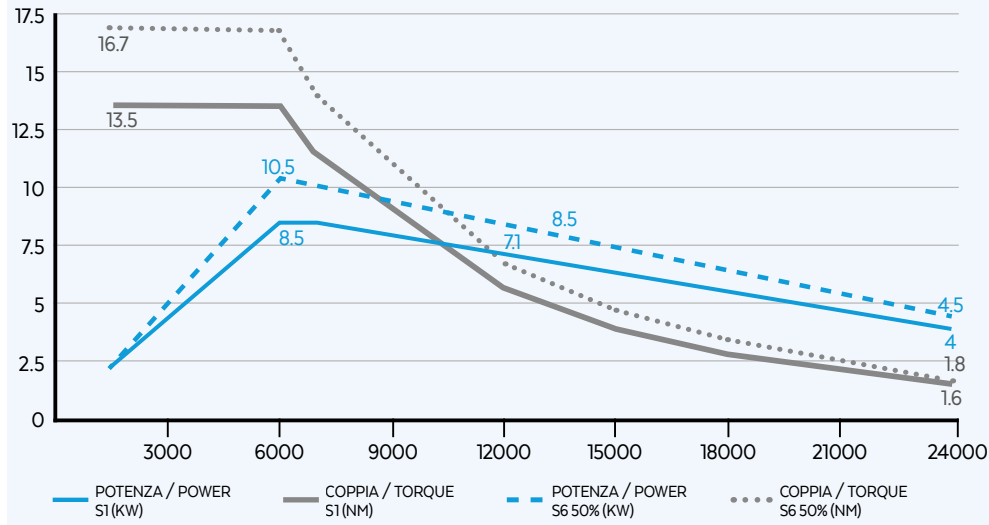

OPZIONALI / OPTIONALS

- Encoder TVpp or TTL
- Circular connector CC
- Quick connection PP
- Long nose
- Air tool
- Voltage 220V
- Bearings temperature monitoring
- Speed monitoring
- Vibration sensor
- C-axes available
- Sensor s5
- ISO 30

SPECIFICHE TECNICHE / TECHNICAL SPECIFICATIONS

- S1-S6 kW** 8.5/10.5
- S1-S6 A** 20/25
- Pol es** 4
- S1-S6 Nm** 13.5/16.7
- Volt** 380
- Supply** inverter
- rpm** 24000
- kg** 24

EQUIPAGGIAMENTO / EQUIPMENT

- HSK 63F
- Electrofan cooling
- Double effect pneumatic cylinder
- Automatic tool changer
- Ceramic ball bearings
- Labyrinth with air seal
- Sensors s1, s2, s3
- Grease lubrication
- Taper cleaning

QE-1F 8.5/12 24

PRESTAZIONI / PERFORMANCES

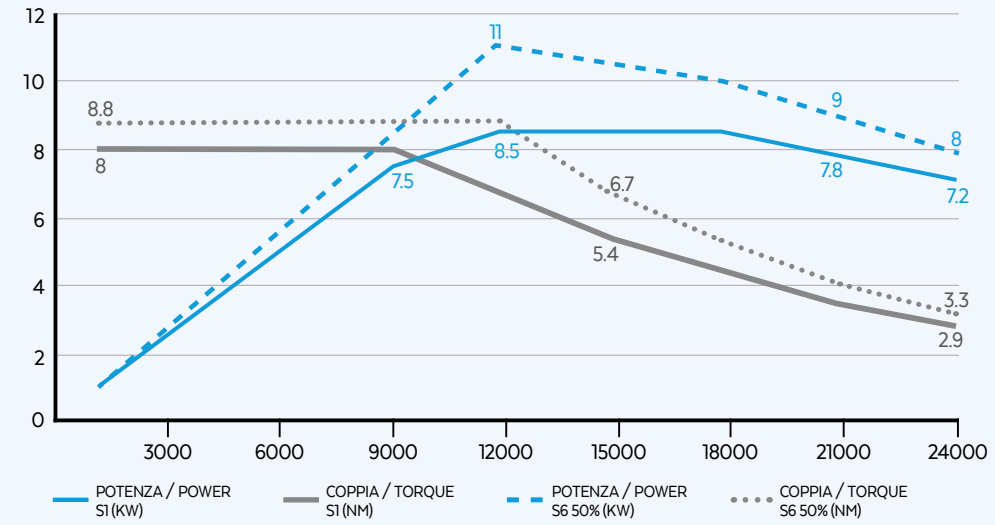

OPZIONALI / OPTIONALS

- Encoder TVpp or TTL
- Circular connector CC
- Quick connection PP
- Long nose
- Air tool
- Voltage 220V
- Bearings temperature monitoring
- Speed monitoring
- Vibration sensor
- C-axes available
- Sensor s5
- ISO 30

SPECIFICHE TECNICHE / TECHNICAL SPECIFICATIONS

- S1-S6 kW** 8/9.5
- S1-S6 A** 18.5/20.5
- Pol es** 4
- S1-S6 Nm** 6.4/7.6
- Volt** 380
- Supply** inverter
- rpm** 24000
- kg** 21

EQUIPAGGIAMENTO / EQUIPMENT

- HSK 63F
- Electrofan cooling
- Double effect pneumatic cylinder
- Automatic tool changer
- Ceramic ball bearings
- Labyrinth with air seal
- Sensors s1, s2, s3
- Grease lubrication
- Taper cleaning
- Pressed air cooling

QE-1F 10/11 24

PRESTAZIONI / PERFORMANCES

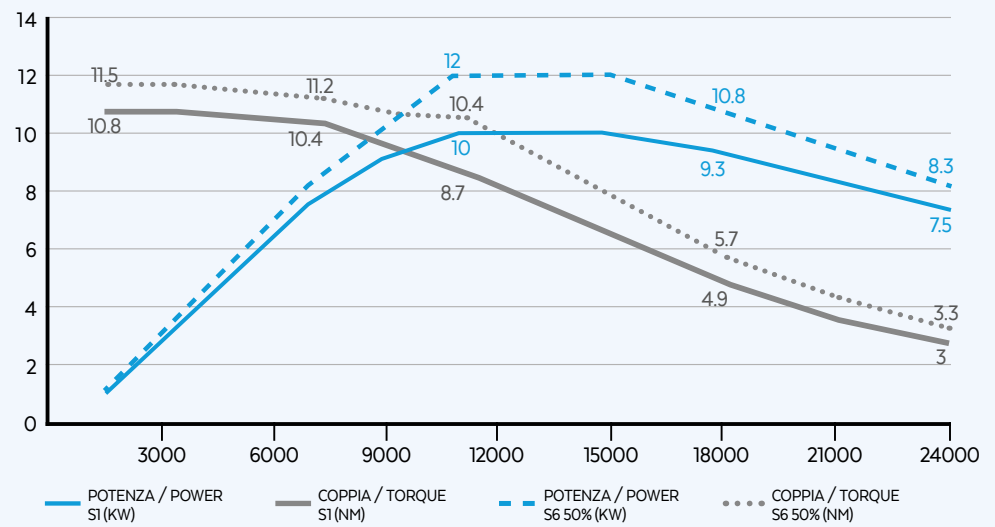

OPZIONALI / OPTIONALS

- Encoder TVpp or TTL
- Circular connector CC
- Quick connection PP
- ISO 30
- Voltage 220V
- Air tool
- Pressed air cooling
- Bearings temperature monitoring
- Speed monitoring
- Vibration sensor
- C-axes available
- Sensor s5
- Long nose

SPECIFICHE TECNICHE / TECHNICAL SPECIFICATIONS

- S1-S6 kW** 10/12
- S1-S6 A** 25/27
- Pol es** 4
- S1-S6 Nm** 10.8/11.5
- Volt** 380
- Supply** inverter
- rpm** 24000
- kg** 23
- Dual voltage 220V-380V

EQUIPAGGIAMENTO / EQUIPMENT

- HSK 63F
- Electrofan cooling
- Double effect pneumatic cylinder
- Automatic tool changer
- Ceramic ball bearings
- Labyrinth with air seal
- Sensors s1, s2, s3
- Grease lubrication
- Taper cleaning



PRESTAZIONI / PERFORMANCES

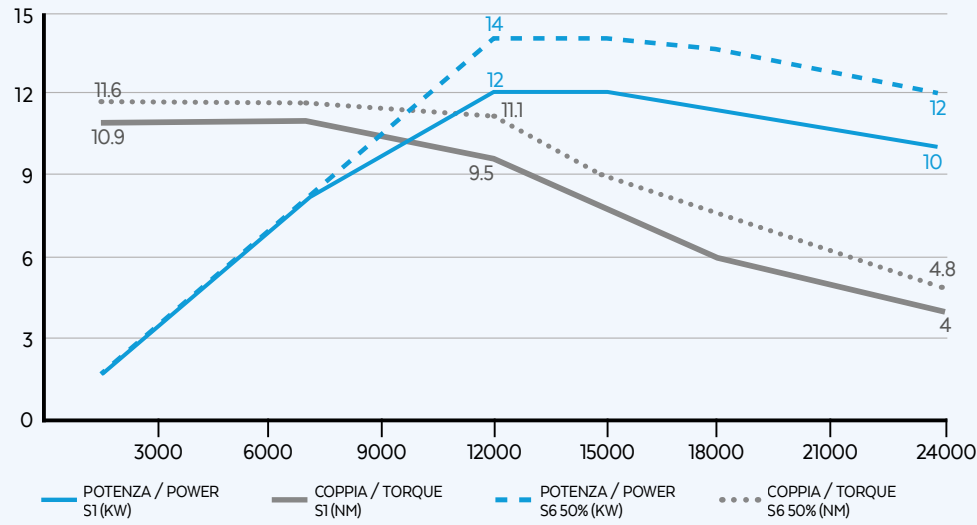

OPZIONALI / OPTIONALS

- Encoder TVpp or TTL
- Circular connector CC
- Quick connection pp
- Air tool
- Long nose
- Pressed air cooling
- Bearings temperature monitoring
- Speed monitoring
- Vibration sensor
- C-axes available
- Sensor s5

SPECIFICHE TECNICHE / TECHNICAL SPECIFICATIONS

S1-S6 kW 12/14
S1-S6 A 23/27
Pol es 4
S1-S6 Nm 10.9/11.6
Volt 380
Supply inverter
rpm 24000
kg 23

EQUIPAGGIAMENTO / EQUIPMENT

HSK 63F
Electrofan cooling
Double effect pneumatic cylinder
Automatic tool changer
Ceramic ball bearings
Sensors s1, s2, s3
Grease lubrication
Labyrinth with air seal
Taper cleaning

LAYOUT HSK 63F CB

LIQUID

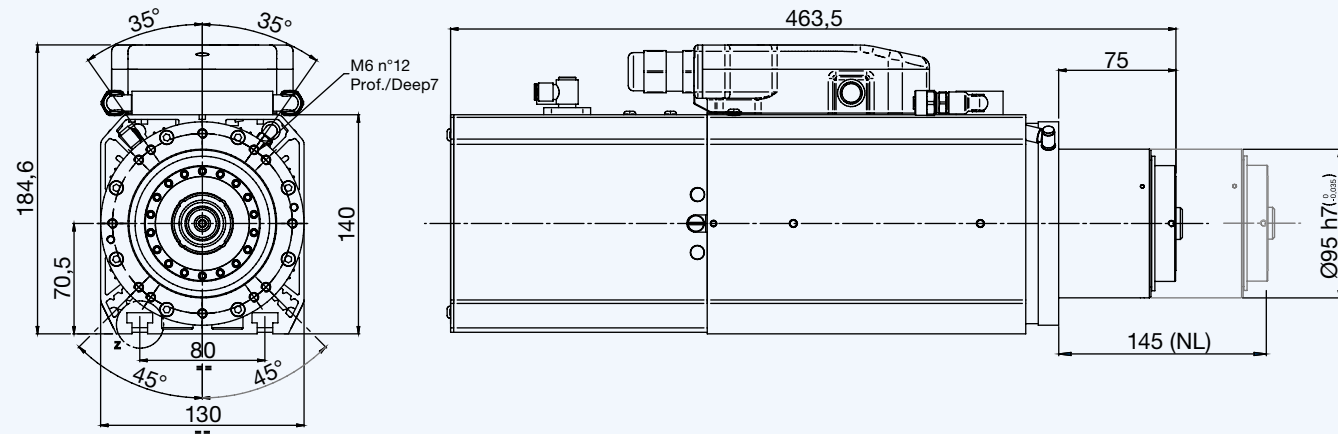

ALTRI LAYOUT / OTHER LAYOUTS

	ΔL	L tot
Encoder (1 Vpp or TTL)	+7 mm	470,5 mm

PRESTAZIONI / PERFORMANCES

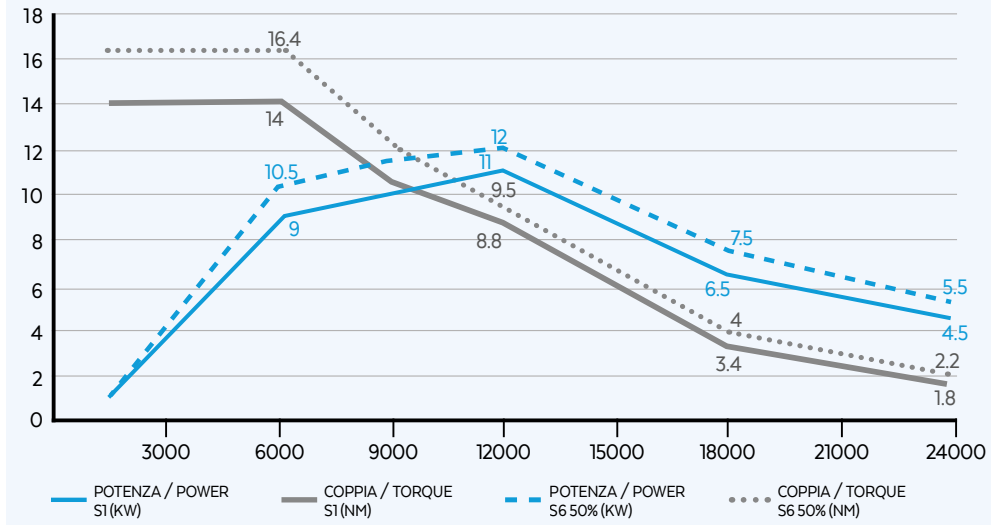

OPZIONALI / OPTIONALS

- Encoder TVpp or TTL
- Circular connector CC
- Quick connection pp
- Air tool
- Long nose
- Bearings temperature monitoring
- Speed monitoring
- Vibration sensor
- C-axes available
- Sensor s5

SPECIFICHE TECNICHE / TECHNICAL SPECIFICATIONS

S1-S6 kW 9/10.5
S1-S6 A 20/22.5
Pol es 4
S1-S6 Nm 14/16.4
Volt 380
Supply inverter
rpm 24000
kg 23

EQUIPAGGIAMENTO / EQUIPMENT

HSK 63F
Liquid cooling
Double effect pneumatic cylinder
Automatic tool changer
Ceramic ball bearings
Labyrinth with air seal
Sensors s1, s2, s3
Grease lubrication
Taper cleaning

QE-2 11/6 24

LIQUID HIGH TORQUE

PRESTAZIONI / PERFORMANCES

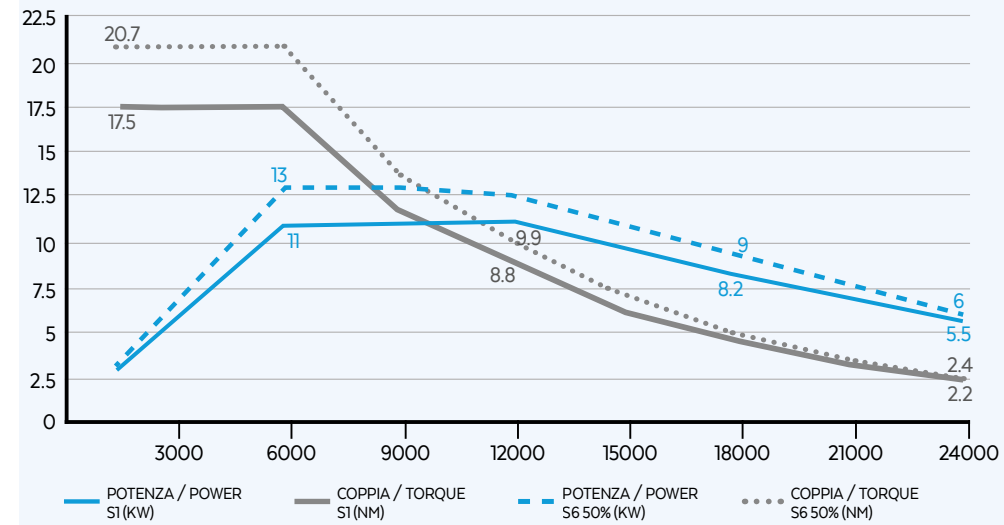

OPZIONALI / OPTIONALS

- Encoder TVpp or TTL
- Circular connector CC
- Quick connection pp
- Air tool
- Long nose
- Bearings temperature monitoring
- Speed monitoring
- Vibration sensor
- C-axes available
- Sensor s5

SPECIFICHE TECNICHE / TECHNICAL SPECIFICATIONS

S1-S6 kW 11/13
S1-S6 A 24/28
Pol es 4
S1-S6 Nm 17.5/20.7
Volt 380
Supply inverter
rpm 24000
kg 23

EQUIPAGGIAMENTO / EQUIPMENT

HSK 63F
Liquid cooling
Double effect pneumatic cylinder
Automatic tool changer
Ceramic ball bearings
Labyrinth with air seal
Sensors s1, s2, s3
Grease lubrication
Taper cleaning

QE-2 13/12 24

LIQUID

PRESTAZIONI / PERFORMANCES

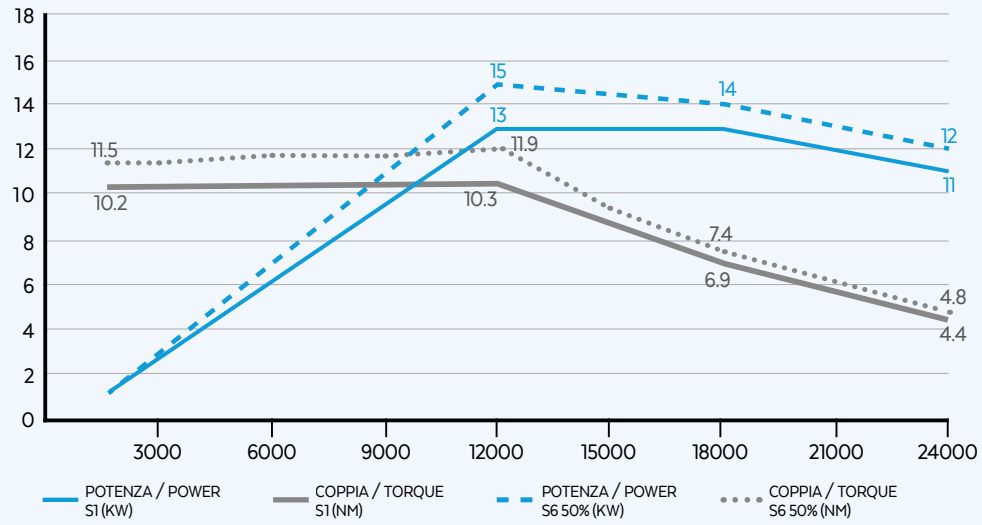

OPZIONALI / OPTIONALS

- Encoder 1 Vpp or TTL
- Circular connector CC
- Quick connection PP
- Air tool
- Long nose
- Bearings temperature monitoring
- Speed monitoring
- Vibration sensor
- C-axes available
- Sensor s5

SPECIFICHE TECNICHE / TECHNICAL SPECIFICATIONS

- S1-S6 kW 13/15
- S1-S6 A 28/31
- Pol es 4
- S1-S6 Nm 10.3/11.9
- Volt 380
- Supply inverter
- rpm 24000
- kg 23

EQUIPAGGIAMENTO / EQUIPMENT

- HSK 63F
- Liquid cooling
- Ceramic ball bearings
- Labyrinth with air seal
- Taper cleaning
- Double effect pneumatic cylinder
- Automatic tool changer
- Sensors s1, s2, s3
- Grease lubrication

QE-2 16/12 24

LIQUID

PRESTAZIONI / PERFORMANCES

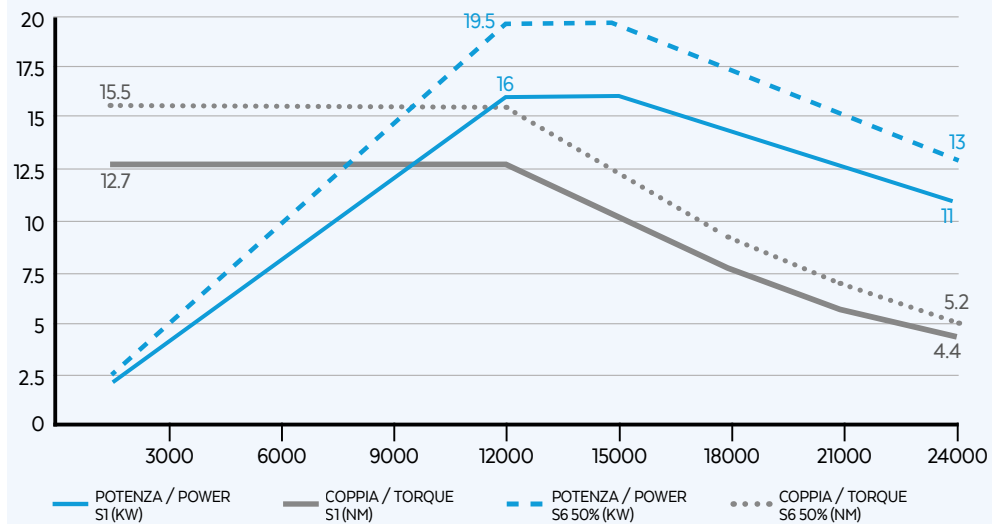

OPZIONALI / OPTIONALS

- Encoder 1 Vpp or TTL
- Circular connector CC
- Quick connection PP
- Air tool
- Long nose
- Bearings temperature monitoring
- Speed monitoring
- Vibration sensor
- C-axes available
- Sensor s5

SPECIFICHE TECNICHE / TECHNICAL SPECIFICATIONS

- S1-S6 kW 16/19.5
- S1-S6 A 31/36
- Pol es 4
- S1-S6 Nm 12.7/15.5
- Volt 380
- Supply inverter
- rpm 24000
- kg 23

EQUIPAGGIAMENTO / EQUIPMENT

- HSK 63F
- Liquid cooling
- Ceramic ball bearings
- Labyrinth with air seal
- Taper cleaning
- Double effect pneumatic cylinder
- Automatic tool changer
- Sensors s1, s2, s3
- Grease lubrication

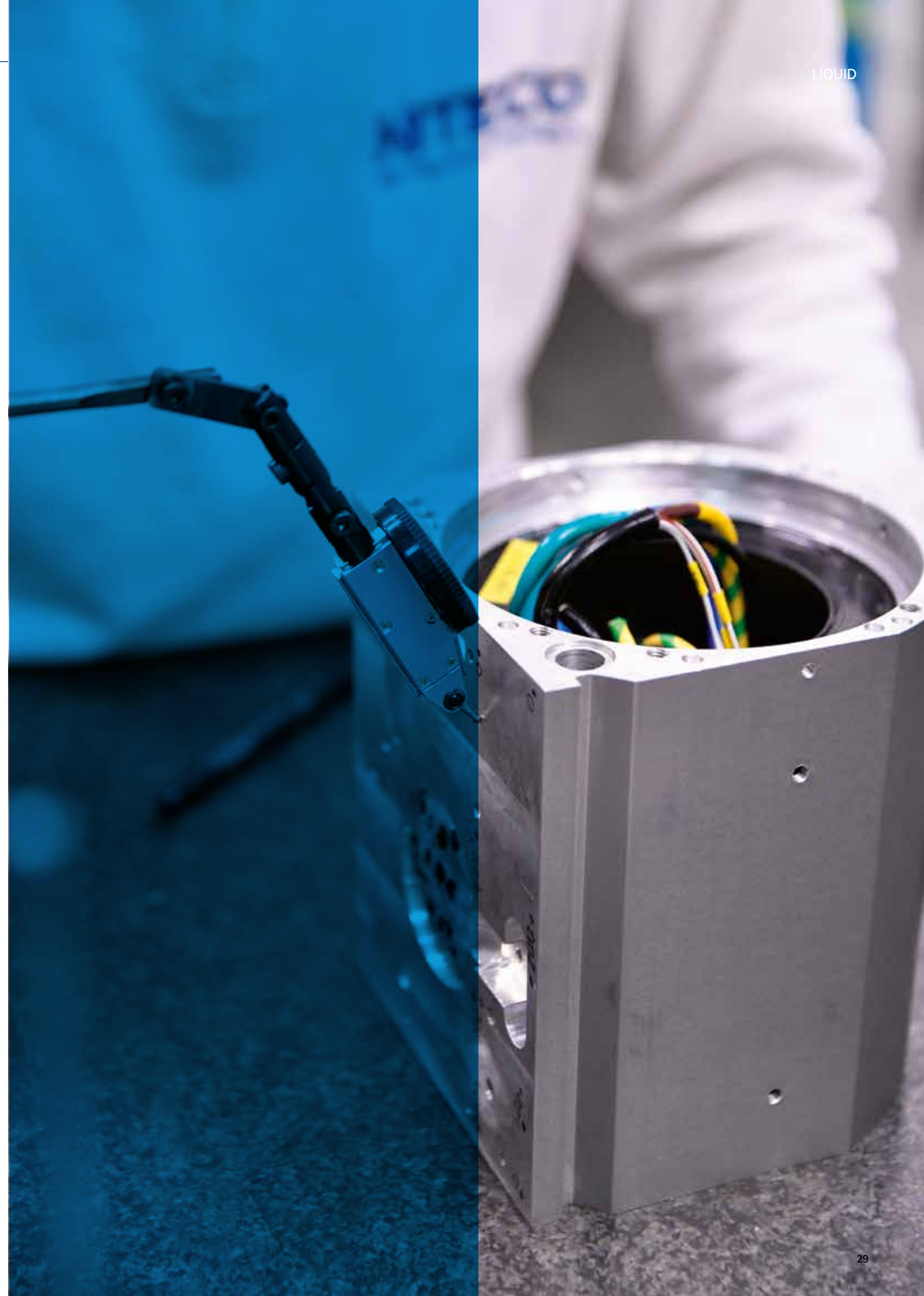

POWERTECH 500



SUITABLE FOR MACHINING WOOD AND ALUMINUM
 WIDE RANGE OF POWER UP TO 18 KW AND HIGH TORQUES FOR HEAVY MACHINING
 HSK 63E VERSIONS FOR WORKING WITH DOUBLE PROFILE TOOLS
 SUITABLE FOR MACHINING WOODEN WINDOWS AND DOORS
 AVAILABLE WITH LIQUID COOLING FOR INTENSIVE PROCESSES

LAYOUT HSK 63F PP

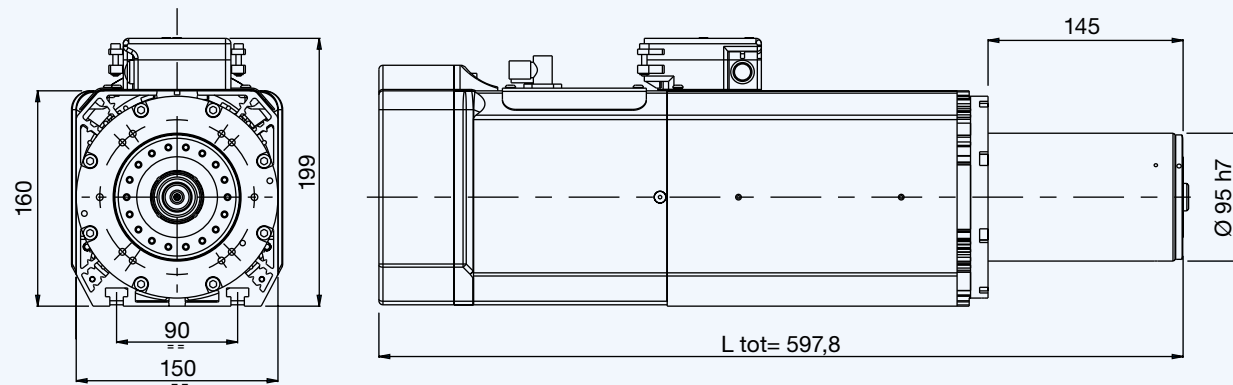

QF-1F 8/9/18

HIGH TORQUE

PRESTAZIONI / PERFORMANCES

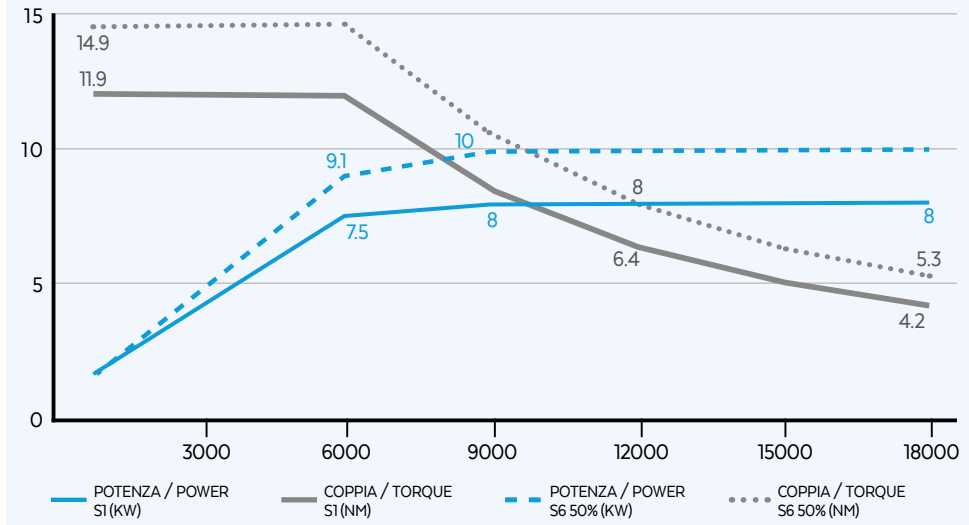

OPZIONALI / OPTIONALS

- Bearings temperature monitoring
- Vibration sensor
- Speed monitoring
- C-AXES
- Quick connection pp machine side
- HSK 63E

SPECIFICHE TECNICHE / TECHNICAL SPECIFICATIONS

- S1-S6 kW 8/10
- S1-S6 Nm 11.9/14.6
- rpm 18000
- S1-S6 A 20/24
- Volt 380
- kg 35
- Pol es 4
- Supply inverter

EQUIPAGGIAMENTO / EQUIPMENT

- HSK 63F
- Ceramic ball bearings
- Taper cleaning
- Electrofan cooling
- Labyrinth with air seal
- Quick connection PP spindle side
- Double effect pneumatic cylinder
- Sensors s1, s2, s3
- Automatic tool changer
- Grease lubrication

QF-1F 13/7/15

HIGH TORQUE

PRESTAZIONI / PERFORMANCES

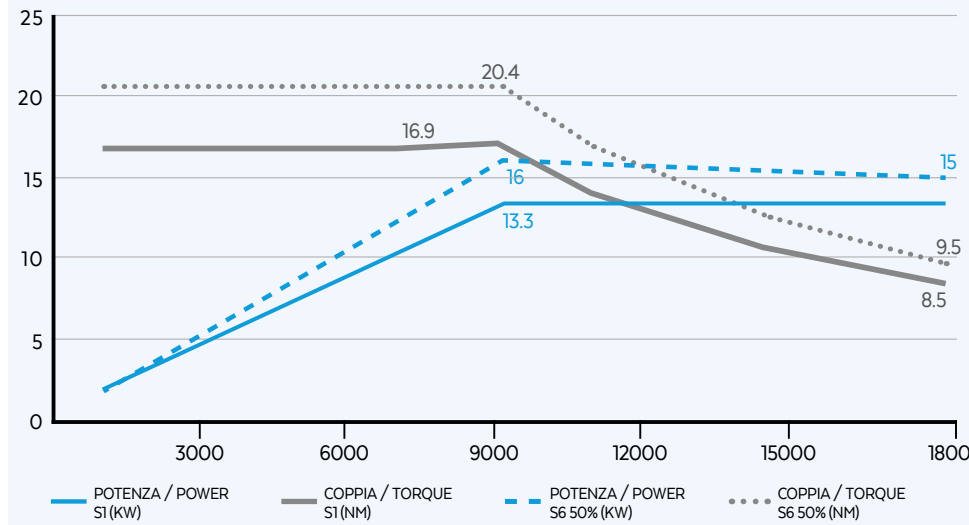

OPZIONALI / OPTIONALS

- Bearings temperature monitoring
- Vibration sensor
- Speed monitoring
- C-AXES
- Quick connection pp machine side
- Temperature sensor
- HSK 63E

SPECIFICHE TECNICHE / TECHNICAL SPECIFICATIONS

- S1-S6 kW 13.3/16
- S1-S6 Nm 16.9/20.4
- rpm 18000
- S1-S6 A 28/32
- Volt 380
- kg 35
- Pol es 4
- Supply inverter

EQUIPAGGIAMENTO / EQUIPMENT

- HSK 63F
- Ceramic ball bearings
- Taper cleaning
- Electrofan cooling
- Labyrinth with air seal
- Quick connection PP spindle side
- Double effect pneumatic cylinder
- Sensors s1, s2, s3
- Automatic tool changer
- Grease lubrication

QF-1F 11/12 20

PRESTAZIONI / PERFORMANCES

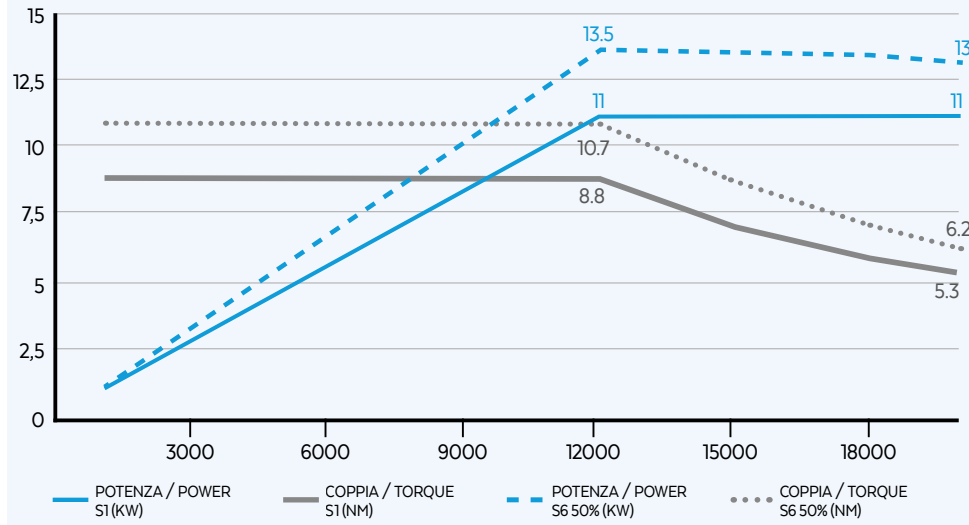

OPZIONALI / OPTIONALS

- Bearings temperature monitoring
- Vibration sensor
- Speed monitoring
- C-AXES C-axis available
- Plug & Play Quick connection pp machine side

SPECIFICHE TECNICHE / TECHNICAL SPECIFICATIONS

- Power: 11/13.5 kW
- Current: 28/32 A
- Pol es 4
- Power: 8.8/10.7 Nm
- Voltage: 380 Volt
- Supply inverter
- rpm: 20000
- Weight: 35 kg

EQUIPAGGIAMENTO / EQUIPMENT

- HSK 63F
- Electrofan cooling
- Double effect pneumatic cylinder
- Automatic tool changer
- Ceramic ball bearings
- Labyrinth with air seal
- Sensors s1, s2, s3
- Grease lubrication
- Taper cleaning
- Plug & Play Quick connection PP spindle side

LAYOUT HSK 63F PP

LIQUID

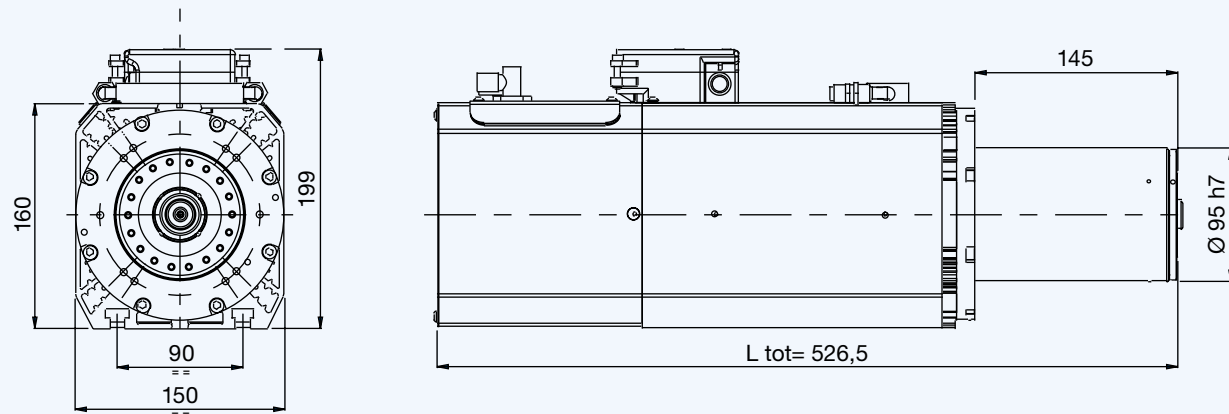

ALTRI LAYOUT / OTHER LAYOUTS

	ΔL	L tot
HSK 63E	+21 mm	547,5 mm

QF-2 12/6 18

LIQUID HIGH TORQUE

PRESTAZIONI / PERFORMANCES

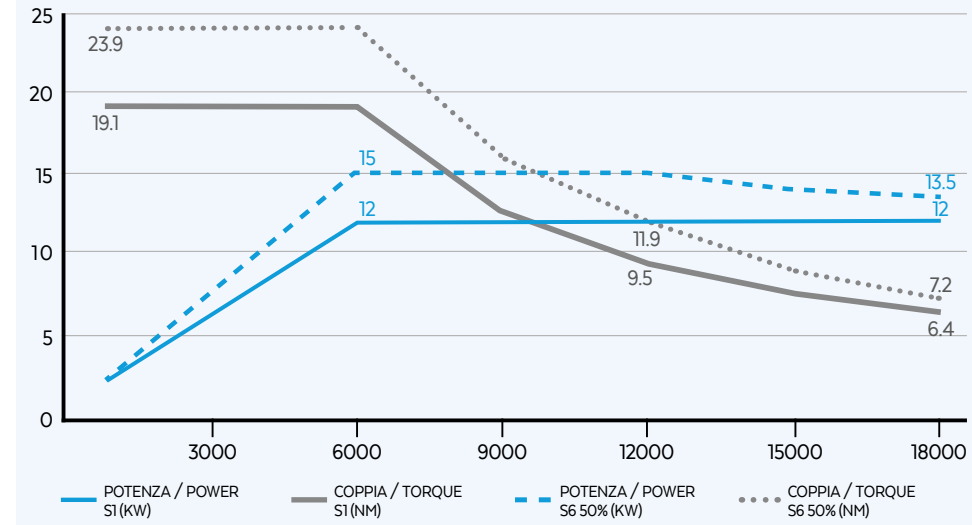

OPZIONALI / OPTIONALS

- Bearings temperature monitoring
- Vibration sensor
- Speed monitoring
- C-AXES C-axis available
- Plug & Play Quick connection pp machine side
- HSK 63E

SPECIFICHE TECNICHE / TECHNICAL SPECIFICATIONS

- Power: 12/15 kW
- Current: 28/35 A
- Pol es 4
- Power: 19.1/23.9 Nm
- Voltage: 380 Volt
- Supply inverter
- rpm: 18000
- Weight: 35 kg

EQUIPAGGIAMENTO / EQUIPMENT

- HSK 63F
- Liquid cooling
- Double effect pneumatic cylinder
- Automatic tool changer
- Ceramic ball bearings
- Labyrinth with air seal
- Sensors s1, s2, s3
- Grease lubrication
- Taper cleaning
- Plug & Play Quick connection PP spindle side

QF-2 18/12 20

LIQUID

PRESTAZIONI / PERFORMANCES

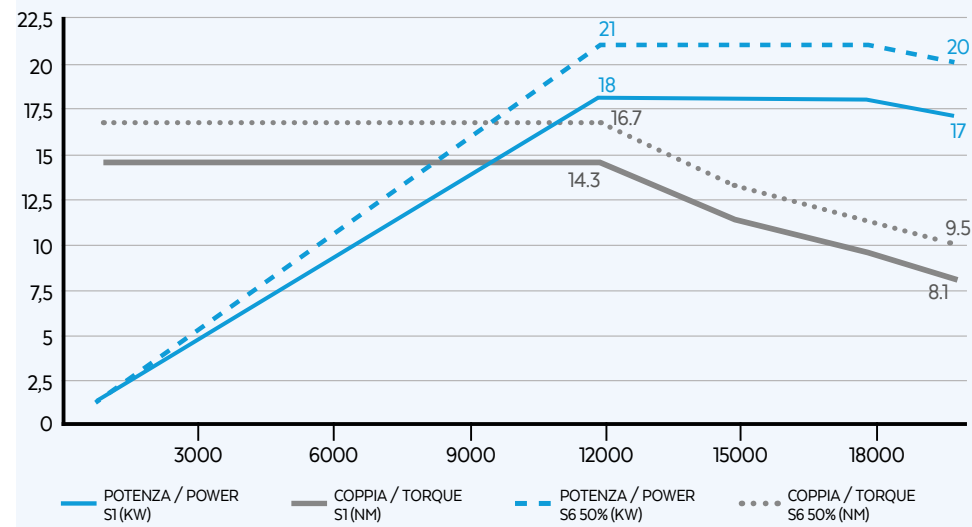

OPZIONALI / OPTIONALS

- Bearings temperature monitoring
- Vibration sensor
- Speed monitoring
- C-AXES C-axis available
- Plug & Play Quick connection pp machine side
- HSK 63E

SPECIFICHE TECNICHE / TECHNICAL SPECIFICATIONS

- Power: 18/21 kW
- Current: 36/41 A
- Pol es 4
- Power: 14.3/16.7 Nm
- Voltage: 380 Volt
- Supply inverter
- rpm: 20000
- Weight: 35 kg

EQUIPAGGIAMENTO / EQUIPMENT

- HSK 63F
- Liquid cooling
- Double effect pneumatic cylinder
- Automatic tool changer
- Ceramic ball bearings
- Labyrinth with air seal
- Sensors s1, s2, s3
- Grease lubrication
- Taper cleaning
- Plug & Play Quick connection PP spindle side

POWERTECH 600



SUITABLE FOR MACHINING WOOD AND ALUMINUM
POWER UP TO 18 KW AND HIGH TORQUES FOR HEAVY MACHINING
AIR COOLING
SUITABLE FOR HEAVY MACHINING ON WOODEN WINDOWS AND DOORS

LAYOUT HSK 80F PP

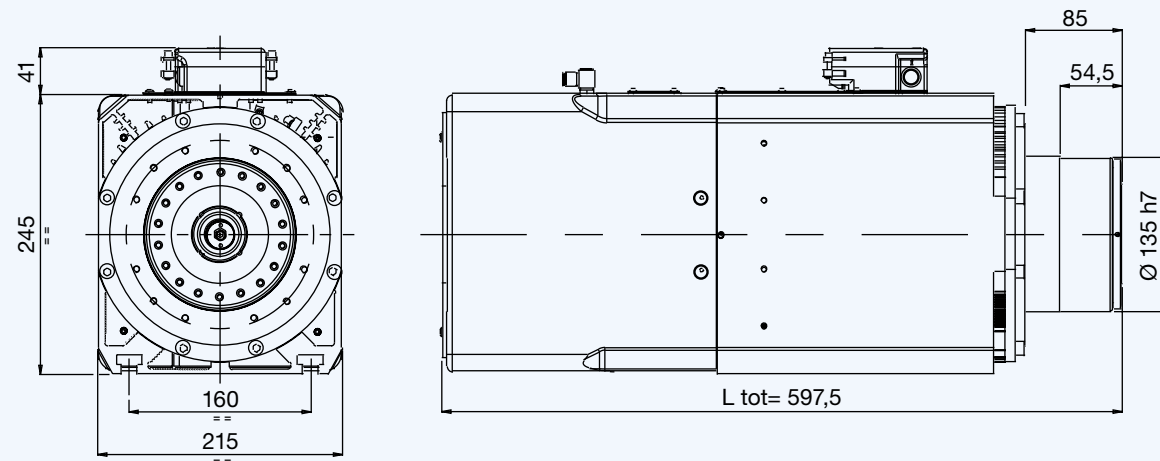

QM-1F 11/6 10

HIGH TORQUE

PRESTAZIONI / PERFORMANCES

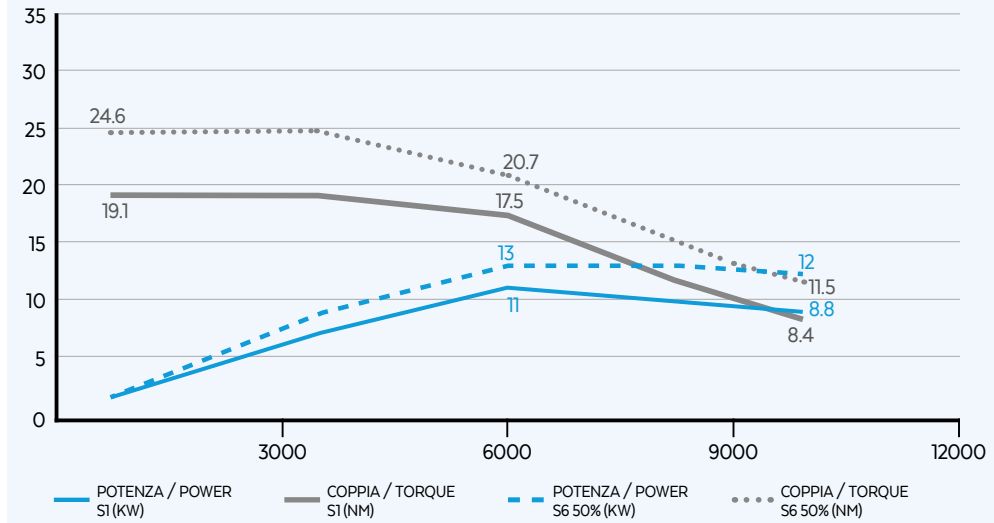

OPZIONALI / OPTIONALS

- Bearings temperature monitoring
- iSPINDLE
- Speed monitoring
- Vibration sensor
- Quick connection pp machine side
- Plug & Play
- HSK 85S

SPECIFICHE TECNICHE / TECHNICAL SPECIFICATIONS

- kW 11/13
- A 25/33
- Pol es 4
- Supply inverter
- Nm 19.1/24.6
- Volt 380
- rpm 10000
- kg 70

EQUIPAGGIAMENTO / EQUIPMENT

- HSK 80F
- Electrofan cooling
- Single effect pneumatic cylinder
- Automatic tool changer
- Ceramic ball bearings
- Labyrinth with air seal
- Sensors s1, s2, s3
- Grease lubrication
- Taper cleaning
- Quick connection PP spindle side

QM-1F 18/6 12

HIGH TORQUE

PRESTAZIONI / PERFORMANCES

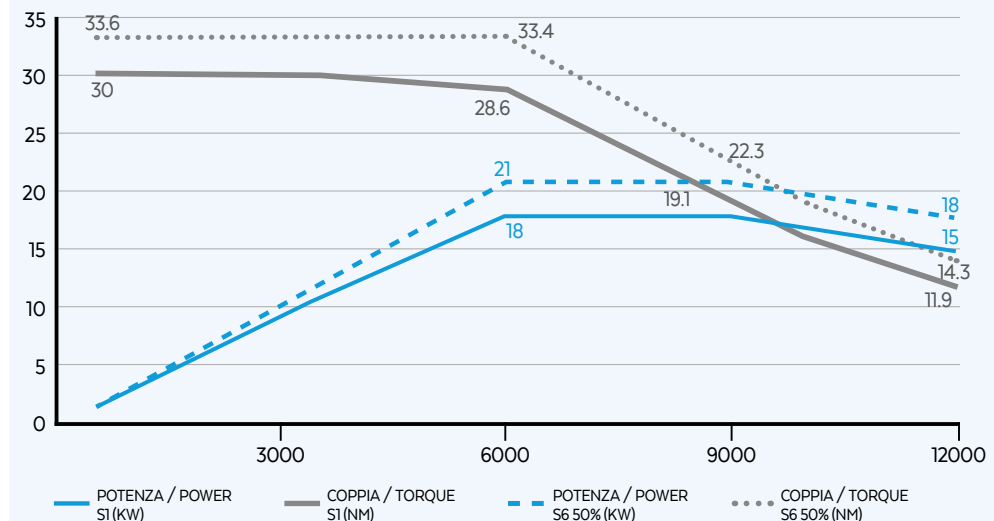

OPZIONALI / OPTIONALS

- Bearings temperature monitoring
- iSPINDLE
- Speed monitoring
- Vibration sensor
- Quick connection pp machine side
- Plug & Play
- HSK 85S

SPECIFICHE TECNICHE / TECHNICAL SPECIFICATIONS

- kW 18/21
- A 37/42
- Pol es 4
- Supply inverter
- Nm 30/33.6
- Volt 380
- rpm 12000
- kg 70

EQUIPAGGIAMENTO / EQUIPMENT

- HSK 80F
- Electrofan cooling
- Single effect pneumatic cylinder
- Automatic tool changer
- Ceramic ball bearings
- Labyrinth with air seal
- Sensors s1, s2, s3
- Grease lubrication
- Taper cleaning
- Quick connection PP spindle side

ROBOTECH QX



SUITABLE FOR MACHINING WOOD AND ALUMINUM
HIGH POWER IN A VERY COMPACT BODY
SUITABLE FOR BI-ROTARY HEADS (50° AND 90°) AND ROBOT APPLICATIONS
AVAILABLE WITH ENCODER ON BOARD

LAYOUT HSK 63F

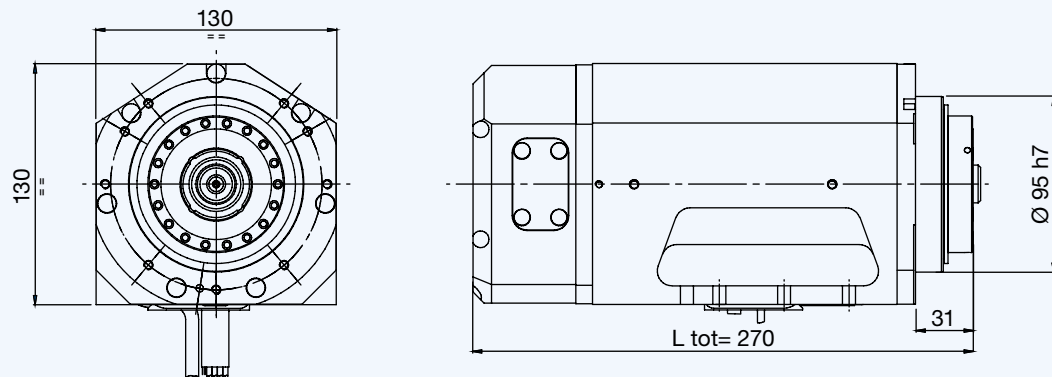

ALTRI LAYOUT / OTHER LAYOUTS

	ΔL	L tot
Encoder (1 Vpp or TTL)	+25 mm	295 mm

QX-2 8.5/12 24

PRESTAZIONI / PERFORMANCES

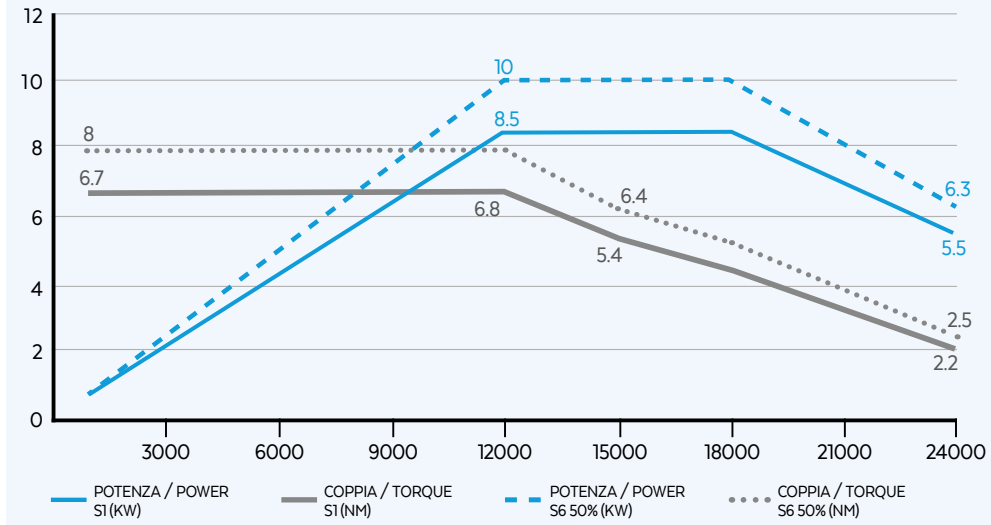

OPZIONALI / OPTIONALS

- Encoder 1Vpp or TTL
- Voltage 220V
- Sensor s5
- Bearings temperature monitoring
- Speed monitoring
- Vibration sensor

SPECIFICHE TECNICHE / TECHNICAL SPECIFICATIONS

- 8.5/10 kW
- 20/22 A
- 4 Poles
- 6.8/8 Nm
- 380 Volt
- inverter Supply
- 24000 rpm
- 18 kg

EQUIPAGGIAMENTO / EQUIPMENT

- HSK 63F
- Liquid cooling
- Single effect pneumatic cylinder
- Automatic tool changer
- Ceramic ball bearings
- Labyrinth with air seal
- Sensors s1, s2, s3
- Grease lubrication
- Taper cleaning

QX-2 10/12 24

PRESTAZIONI / PERFORMANCES

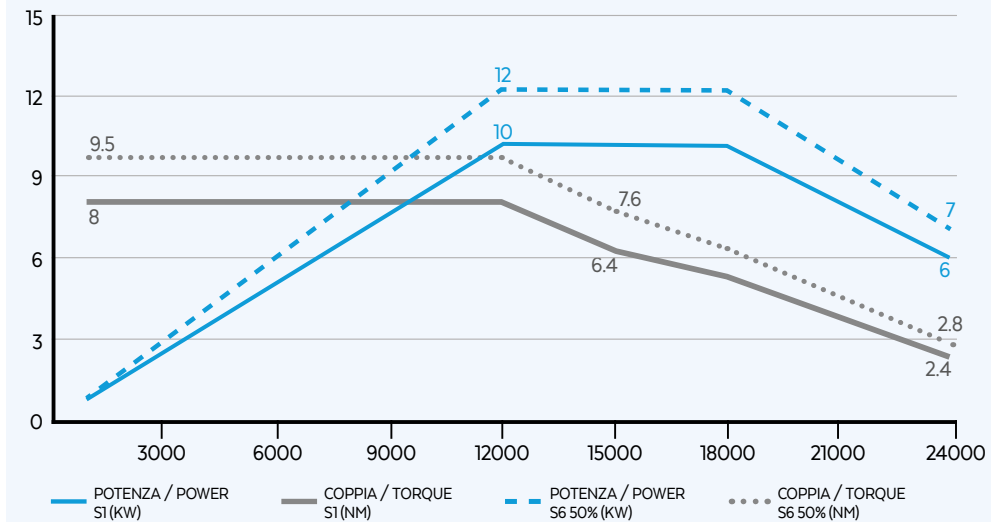

OPZIONALI / OPTIONALS

- Encoder 1Vpp or TTL
- Voltage 220V
- Sensor s5
- Bearings temperature monitoring
- Speed monitoring
- Vibration sensor

SPECIFICHE TECNICHE / TECHNICAL SPECIFICATIONS

- 10/12 kW
- 23/26 A
- 4 Poles
- 8/9.5 Nm
- 380 Volt
- inverter Supply
- 24000 rpm
- 19 kg

EQUIPAGGIAMENTO / EQUIPMENT

- HSK 63F
- Liquid cooling
- Single effect pneumatic cylinder
- Automatic tool changer
- Ceramic ball bearings
- Labyrinth with air seal
- Sensors s1, s2, s3
- Grease lubrication
- Taper cleaning

QX-2 11/12 24

PRESTAZIONI / PERFORMANCES

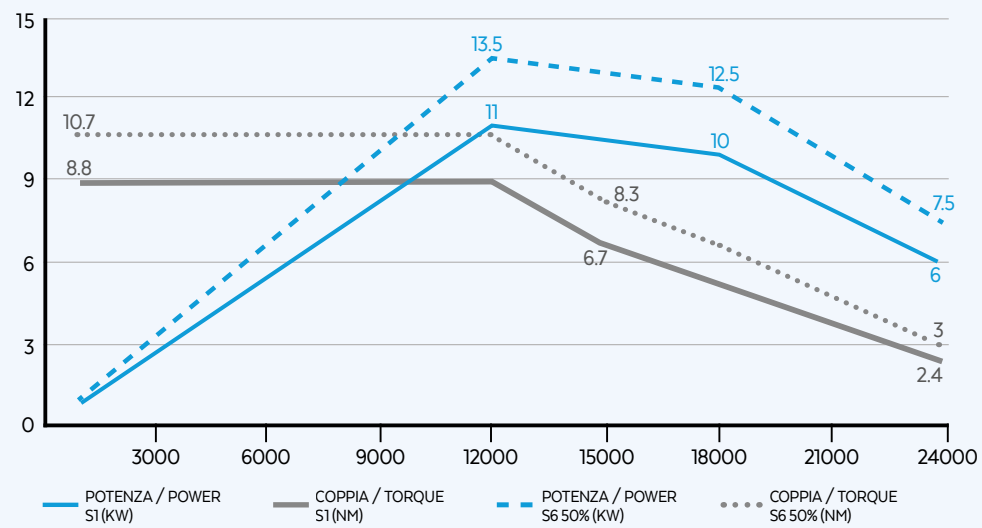

OPZIONALI / OPTIONALS

- Encoder 1Vpp or TTL
- Bearings temperature monitoring
- Sensor s5
- Speed monitoring
- Vibration sensor

SPECIFICHE TECNICHE / TECHNICAL SPECIFICATIONS

- S1-S6 kW** 11/13.5
- S1-S6 A** 24.5/29.5
- Pol es** 4
- S1-S6 Nm** 8.8/10.7
- Volt** 380
- Supply** inverter
- rpm** 24000
- kg** 19

EQUIPAGGIAMENTO / EQUIPMENT

- HSK 63F
- Liquid cooling
- Single effect pneumatic cylinder
- Automatic tool changer
- Ceramic ball bearings
- Labyrinth with air seal
- Sensors s1, s2, s3
- Grease lubrication
- Taper cleaning

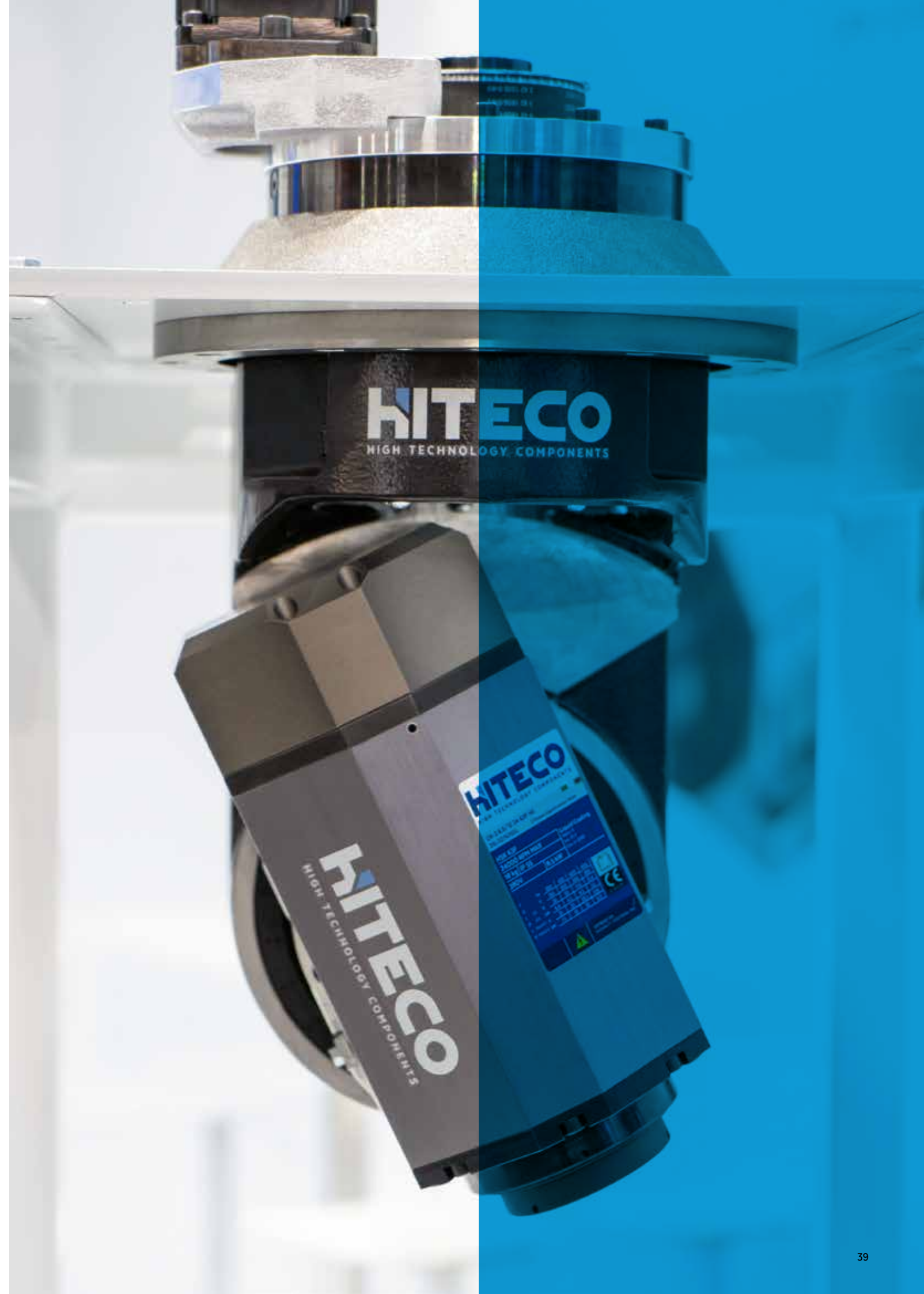

ROBOTECH QX HIGH SPEED



SUITABLE FOR MACHINING PLASTICS, ALUMINUM AND COMPOSITES
HIGH SPEED UP TO 40K RPM
SUITABLE FOR BI-ROTARY HEADS (50° AND 90°) AND ROBOT APPLICATIONS
AVAILABLE WITH ENCODER ON BOARD

LAYOUT HSK 32E / HSK 40E

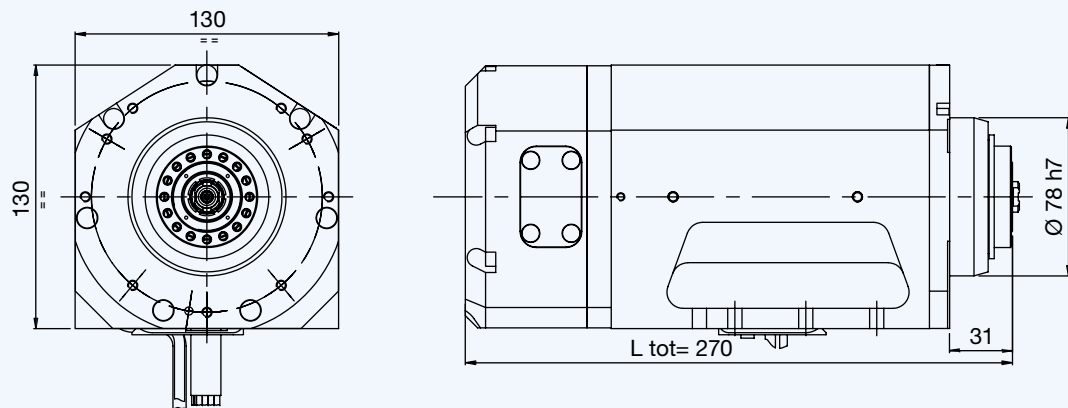

HIGH SPEED

QX-2 8/15 36

PRESTAZIONI / PERFORMANCES

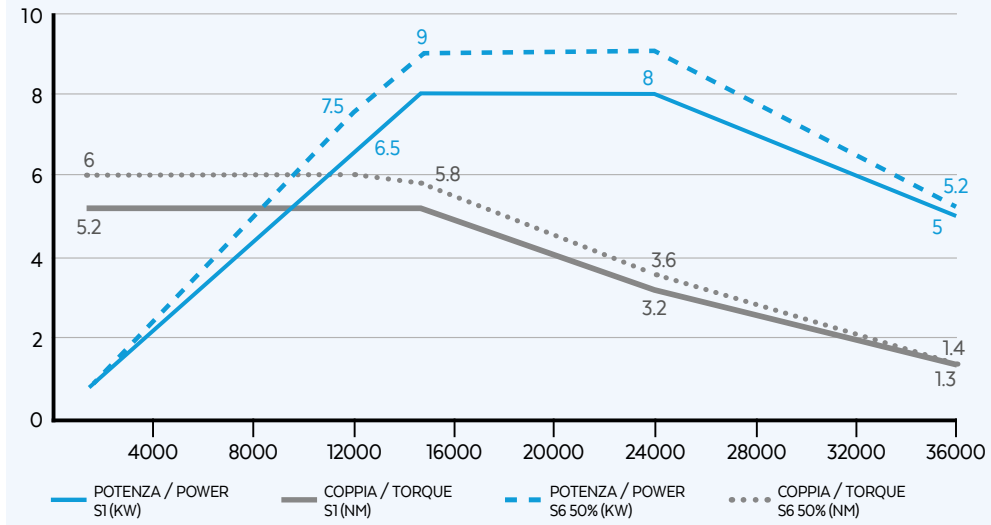

OPZIONALI / OPTIONALS

- Encoder TVpp or TTL
- Sensor s5
- Bearings temperature monitoring
- Vibration sensor
- Speed monitoring

SPECIFICHE TECNICHE / TECHNICAL SPECIFICATIONS

- S1-S6 kW 8/9
- S1-S6 A 23/25
- Pol es 4
- S1-S6 Nm 5.2/6
- Volt 380
- Supply inverter
- rpm 36000
- kg 18

EQUIPAGGIAMENTO / EQUIPMENT

- HSK 40E
- Liquid cooling
- Single effect pneumatic cylinder
- Automatic tool changer
- Ceramic ball bearings
- Labyrinth with air seal
- Sensors s1, s2, s3
- Grease lubrication
- Taper cleaning

QX-2 8/15 40

HIGH SPEED

PRESTAZIONI / PERFORMANCES

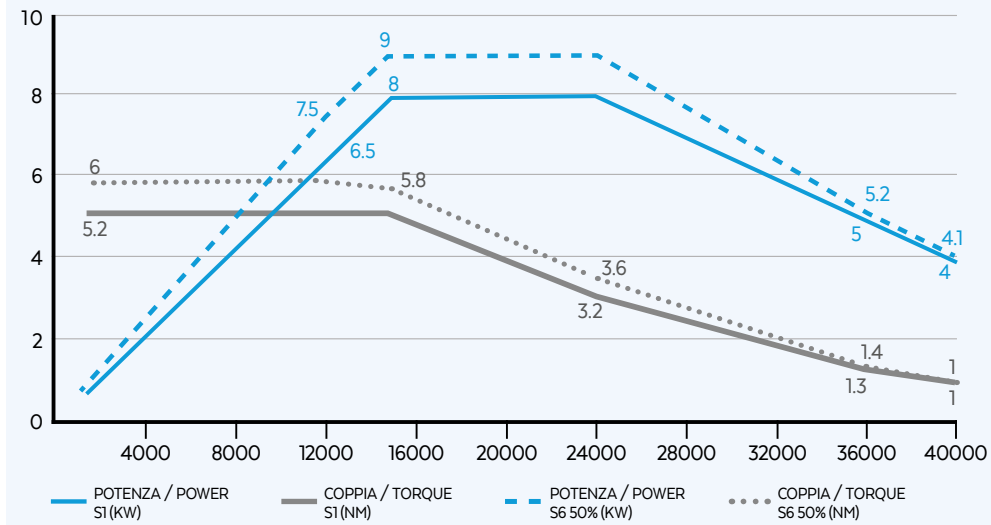

OPZIONALI / OPTIONALS

- Encoder TVpp or TTL
- Sensor s5
- Bearings temperature monitoring
- Vibration sensor
- Speed monitoring

SPECIFICHE TECNICHE / TECHNICAL SPECIFICATIONS

- S1-S6 kW 8/9
- S1-S6 A 23/25
- Pol es 4
- S1-S6 Nm 5.2/6
- Volt 380
- Supply inverter
- rpm 40000
- kg 18

EQUIPAGGIAMENTO / EQUIPMENT

- HSK 32E
- Liquid cooling
- Single effect pneumatic cylinder
- Automatic tool changer
- Ceramic ball bearings
- Labyrinth with air seal
- Sensors s1, s2, s3
- Grease lubrication
- Taper cleaning

ROBOTECH PX-HX



SUITABLE FOR MACHINING WOOD, PLASTICS, ALUMINUM AND COMPOSITES
POWER UP TO 20 KW AND HIGH TORQUES FOR HEAVY MACHINING
OPTIMAL DESIGN FOR BI-ROTARY HEADS (50° AND 90°)
AND ROBOT APPLICATIONS AVAILABLE WITH ENCODER ON BOARD,
LONG NOSE WITH 5 BEARINGS, AIR TOOL, MQL AND OIL MIST
AVAILABLE WITH HSK63F, HSK 63E AND HSK 63A

LAYOUT PX HSK 63F

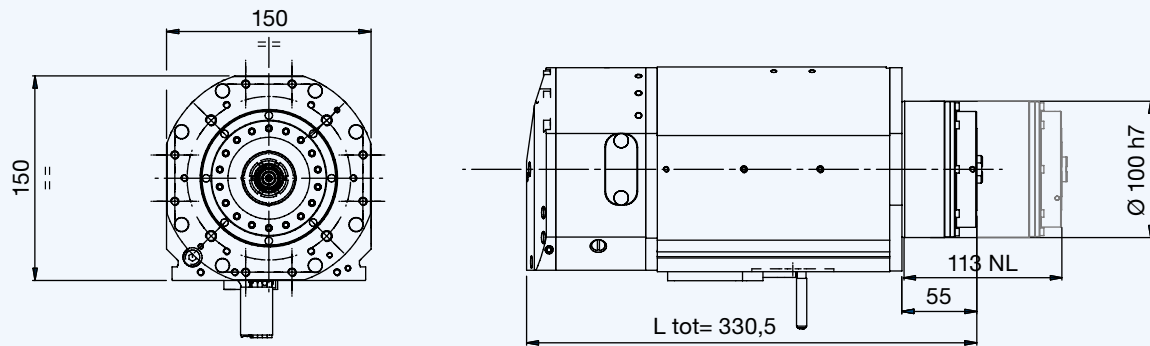

LAYOUT HX HSK 63F

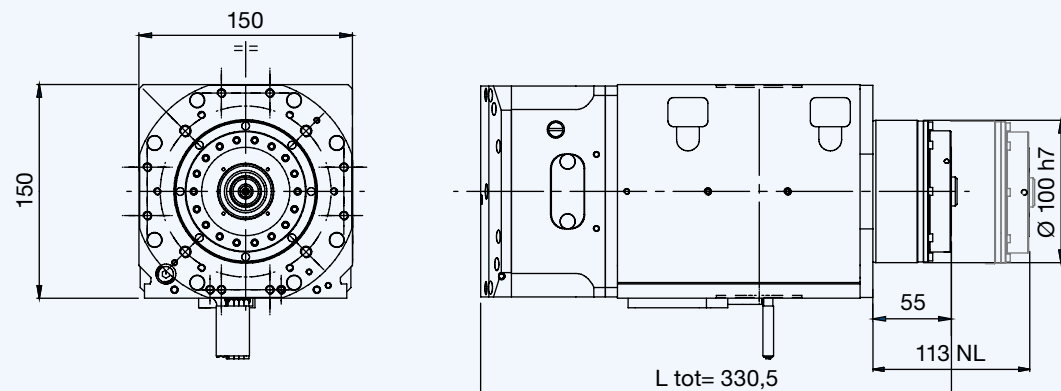

PX/HX-2 10/7 24

HIGH TORQUE

PRESTAZIONI / PERFORMANCES

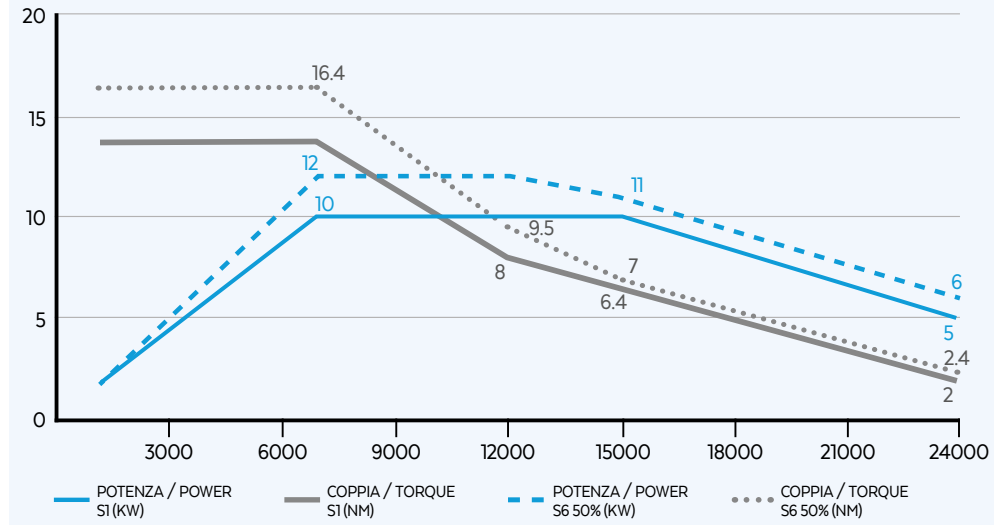

OPZIONALI / OPTIONALS

- Encoder TVpp or TTL
- Long nose
- Air tool
- Sensor s5
- Oil mist/MQL
- Bearings temperature monitoring
- Speed monitoring
- Vibration sensor
- HSK 63E/63A

SPECIFICHE TECNICHE / TECHNICAL SPECIFICATIONS

- Power: 10/12 kW
- Torque: 13.6/16.4 Nm
- Speed: 24000 rpm
- Current: 21/25 A
- Voltage: 380 Volt
- Weight: 25 kg
- 4 Poles
- Inverter supply

EQUIPAGGIAMENTO / EQUIPMENT

- HSK 63F
- Ceramic ball bearings
- Taper cleaning
- Liquid cooling
- Labyrinth with air seal
- Single effect pneumatic cylinder
- Sensors s1, s2, s3
- Automatic tool changer
- Grease lubrication

PX/HX-2 12/12 24

PRESTAZIONI / PERFORMANCES

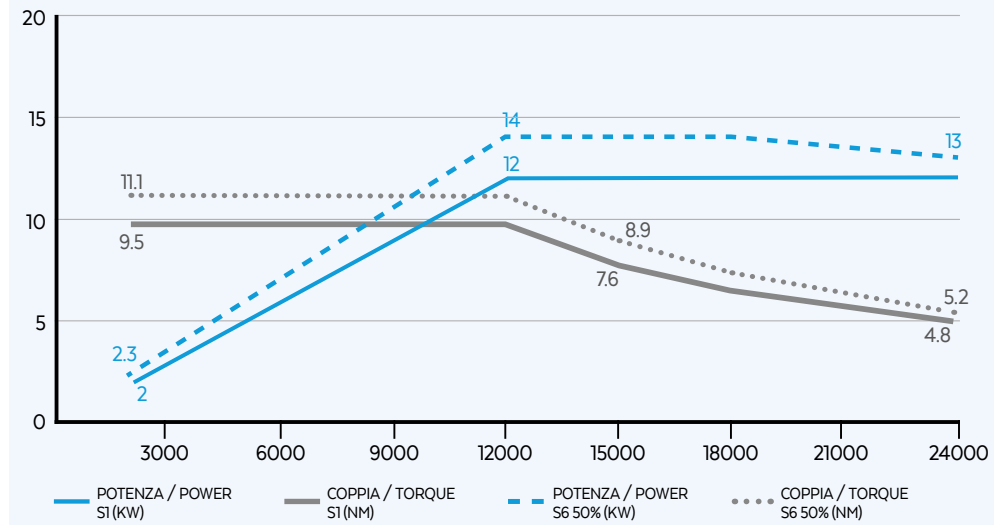

OPZIONALI / OPTIONALS

- Encoder TVpp or TTL
- Long nose
- Air tool
- Sensor s5
- Oil mist/MQL
- Bearings temperature monitoring
- Speed monitoring
- Vibration sensor
- HSK 63E/63A

SPECIFICHE TECNICHE / TECHNICAL SPECIFICATIONS

- Power: 12/14 kW
- Torque: 9.5/11.1 Nm
- Speed: 24000 rpm
- Current: 26/29 A
- Voltage: 380 Volt
- Weight: 25 kg
- 4 Poles
- Inverter supply

EQUIPAGGIAMENTO / EQUIPMENT

- HSK 63F
- Ceramic ball bearings
- Taper cleaning
- Liquid cooling
- Labyrinth with air seal
- Single effect pneumatic cylinder
- Sensors s1, s2, s3
- Automatic tool changer
- Grease lubrication

PX/HX-2 15/12 24

PRESTAZIONI / PERFORMANCES

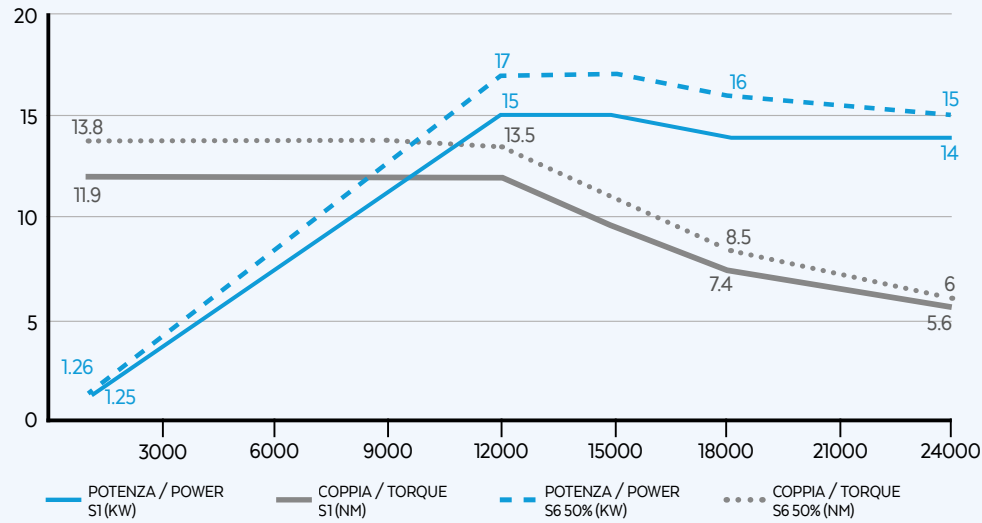

OPZIONALI / OPTIONALS

- Encoder 1Vpp or TTL
- Long nose
- Air tool
- Sensor s5
- Oil mist/MQL
- Bearings temperature monitoring
- Speed monitoring
- Vibration sensor
- HSK 63E/63A

SPECIFICHE TECNICHE / TECHNICAL SPECIFICATIONS

- S1-S6 kW** 15/17
- S1-S6 A** 30/33
- Pol es** 4
- S1-S6 Nm** 11.9/13.8
- Volt** 380
- Supply** inverter
- rpm** 24000
- kg** 25

EQUIPAGGIAMENTO / EQUIPMENT

- HSK 63F
- Liquid cooling
- Single effect pneumatic cylinder
- Automatic tool changer
- Ceramic ball bearings
- Labyrinth with air seal
- Sensors s1, s2, s3
- Grease lubrication
- Taper cleaning

PX/HX-2 18/12 24

PRESTAZIONI / PERFORMANCES

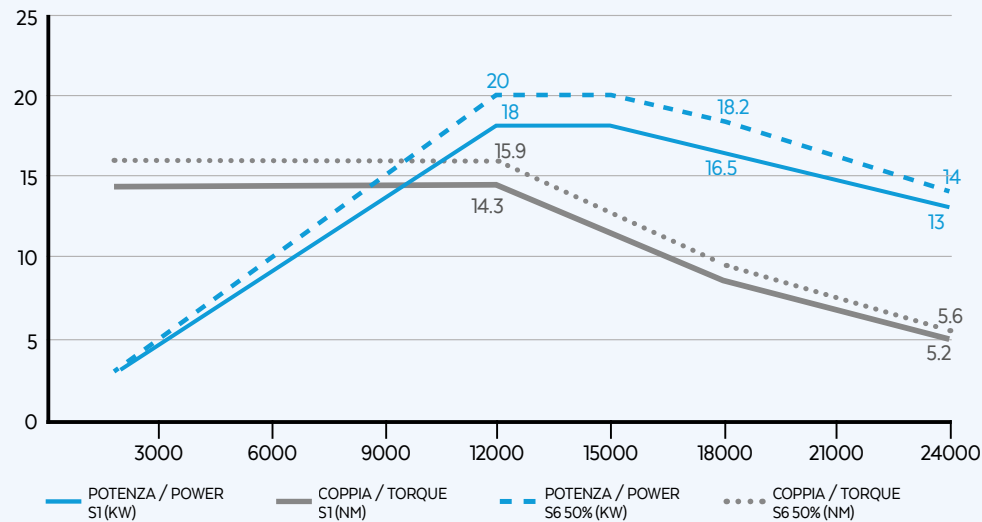

OPZIONALI / OPTIONALS

- Encoder 1Vpp or TTL
- Long nose
- Air tool
- Sensor s5
- Oil mist/MQL
- Bearings temperature monitoring
- Speed monitoring
- Vibration sensor
- HSK 63E/63A

SPECIFICHE TECNICHE / TECHNICAL SPECIFICATIONS

- S1-S6 kW** 18/20
- S1-S6 A** 35/38.5
- Pol es** 4
- S1-S6 Nm** 14.3/15.9
- Volt** 380
- Supply** inverter
- rpm** 24000
- kg** 25

EQUIPAGGIAMENTO / EQUIPMENT

- HSK 63F
- Liquid cooling
- Single effect pneumatic cylinder
- Automatic tool changer
- Ceramic ball bearings
- Labyrinth with air seal
- Sensors s1, s2, s3
- Grease lubrication
- Taper cleaning

PX/HX-2 20/10 24 (SYNCHRONOUS)

PRESTAZIONI / PERFORMANCES

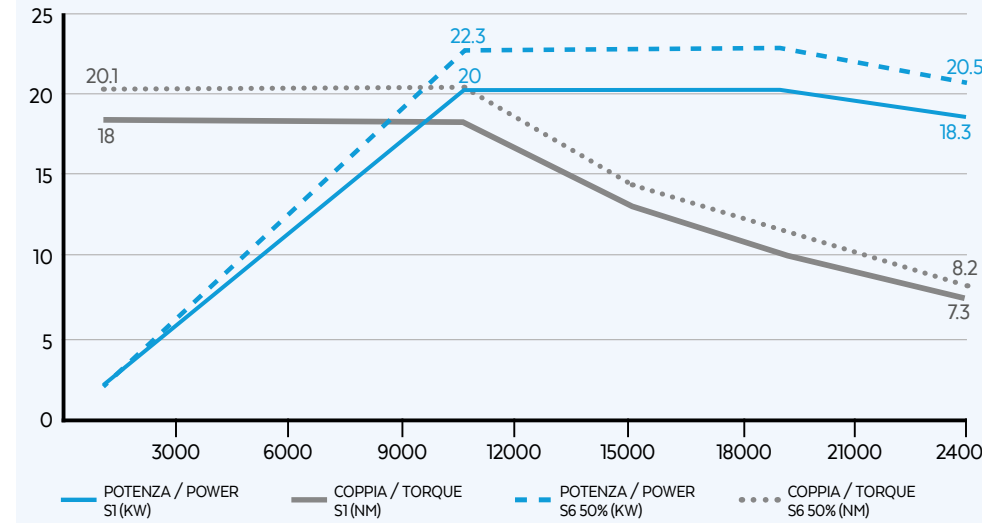

OPZIONALI / OPTIONALS

- Long nose
- Air tool
- Sensor s5
- Oil mist/MQL
- Bearings temperature monitoring
- Speed monitoring
- Vibration sensor
- HSK 63E

SPECIFICHE TECNICHE / TECHNICAL SPECIFICATIONS

- S1-S6 kW** 20/22.3
- S1-S6 A** 48/50
- Pol es** 4
- S1-S6 Nm** 17.8/20.1
- Volt** 380
- Supply** inverter
- rpm** 24000
- kg** 25

EQUIPAGGIAMENTO / EQUIPMENT

- HSK 63A
- Liquid cooling
- Single effect pneumatic cylinder
- Automatic tool changer
- Ceramic ball bearings
- Labyrinth with air seal
- Sensors s1, s2, s3
- Grease lubrication
- Taper cleaning
- Encoder 1Vpp



ROBOTECH HX 3C

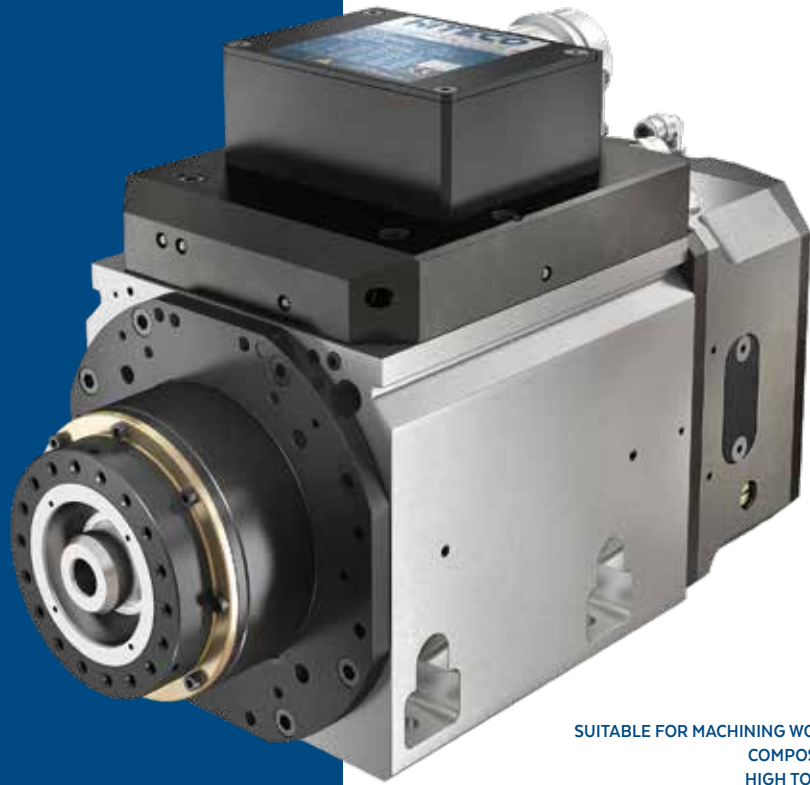

SUITABLE FOR MACHINING WOOD, PLASTICS, ALUMINUM AND COMPOSITES POWER UP TO 20 KW AND HIGH TORQUES FOR HEAVY MACHINING
OPTIMAL DESIGN FOR 3-AXIS MACHINES CONNECTION TO THE MACHINE WITH COMMERCIAL CONNECTORS AVAILA WITH ENCODER ON BOARD, LONG NOSE WITH 5 BEARINGS, AIR TOOL, MQL AND OIL MIST

LAYOUT HSK 63F 3C

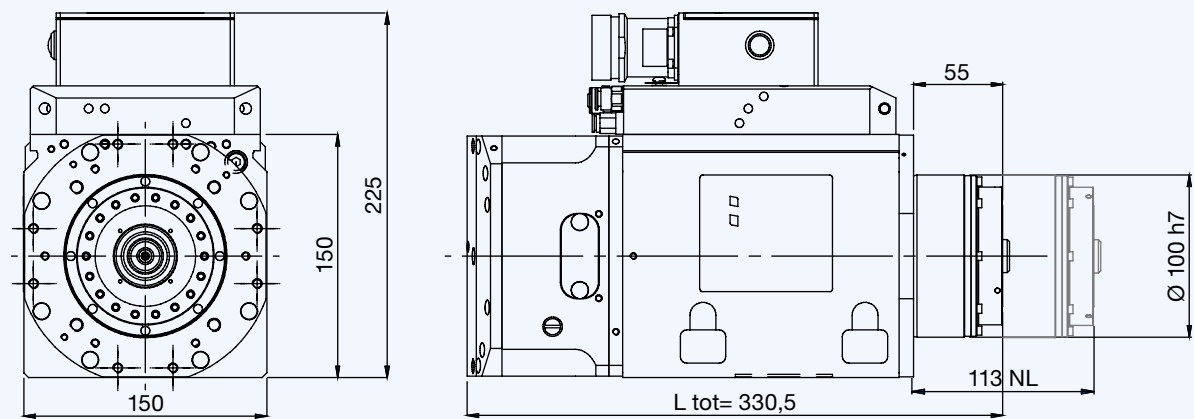

HIGH TORQUE

HX-2 10/7 24 3C

PRESTAZIONI / PERFORMANCES

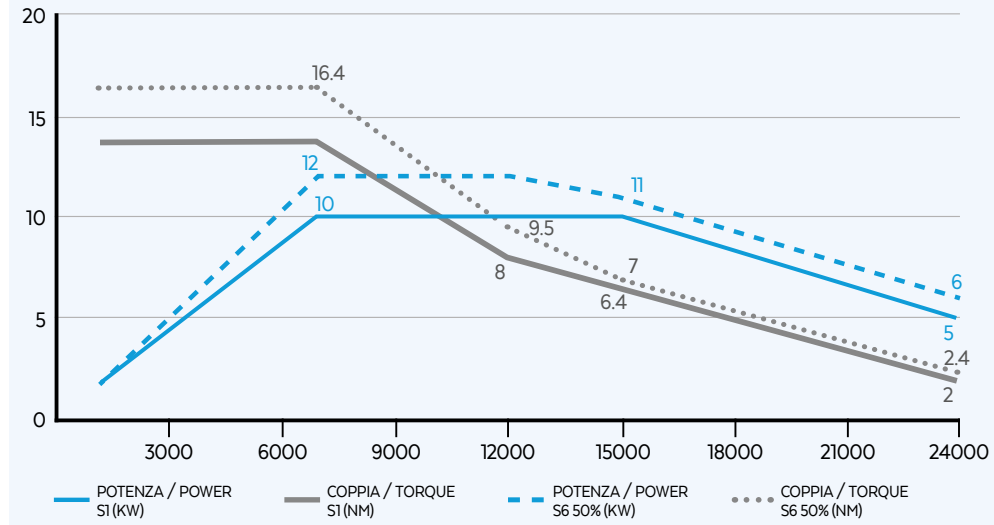

OPZIONALI / OPTIONALS

- Encoder TVpp or TTL
- Circular connector cc machine side
- Long nose
- Air tool
- Sensor s5
- Bearings temperature monitoring
- Speed monitoring
- Vibration sensor
- HSK 63E/63A
- Oil mist/MQL

SPECIFICHE TECNICHE / TECHNICAL SPECIFICATIONS

- kW** 10/12
- Nm** 13.6/16.4
- rpm** 24000
- A** 21/25
- Volt** 380
- kg** 25
- Pol es** 4
- Supply** inverter

EQUIPAGGIAMENTO / EQUIPMENT

- HSK 63F
- Ceramic ball bearings
- Circular connector cc spindle side
- Liquid cooling
- Labyrinth with air seal
- Taper cleaning
- Single effect pneumatic cylinder
- Automatic tool changer
- Sensors s1, s2, s3
- Grease lubrication

HX-2 12/12 24 3C

PRESTAZIONI / PERFORMANCES

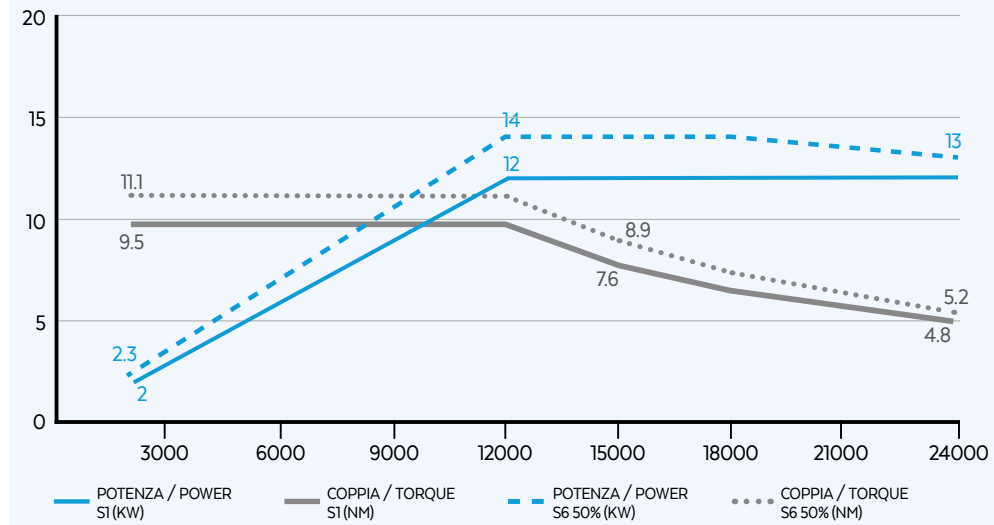

OPZIONALI / OPTIONALS

- Encoder TVpp or TTL
- Circular connector cc machine side
- Long nose
- Air tool
- Sensor s5
- Bearings temperature monitoring
- Speed monitoring
- Vibration sensor
- HSK 63E/63A
- Oil mist/MQL

SPECIFICHE TECNICHE / TECHNICAL SPECIFICATIONS

- kW** 12/14
- Nm** 9.5/11.1
- rpm** 24000
- A** 26/29
- Volt** 380
- kg** 25
- Pol es** 4
- Supply** inverter

EQUIPAGGIAMENTO / EQUIPMENT

- HSK 63F
- Ceramic ball bearings
- Circular connector cc spindle side
- Liquid cooling
- Labyrinth with air seal
- Taper cleaning
- Single effect pneumatic cylinder
- Automatic tool changer
- Sensors s1, s2, s3
- Grease lubrication

HX-2 15/12 24 3C

PRESTAZIONI / PERFORMANCES

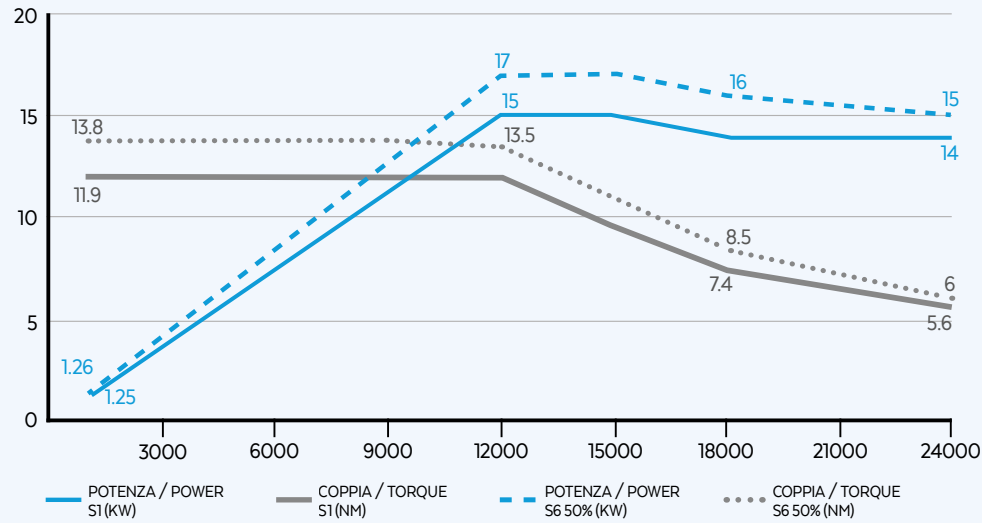

OPZIONALI / OPTIONALS

- Encoder 1Vpp or TTL
- Circular connector cc machine side
- Long nose
- Air tool
- Sensor s5
- Bearings temperature monitoring
- Speed monitoring
- Vibration sensor
- HSK 63E/63A
- Oil mist/MQL

SPECIFICHE TECNICHE / TECHNICAL SPECIFICATIONS

- S1-S6 kW** 15/17
- S1-S6 A** 30/33
- Pol es** 4
- S1-S6 Nm** 11.9/13.8
- Volt** 380
- Supply** inverter
- rpm** 24000
- kg** 25

EQUIPAGGIAMENTO / EQUIPMENT

- HSK 63F
- Liquid cooling
- Single effect pneumatic cylinder
- Automatic tool changer
- Ceramic ball bearings
- Labyrinth with air seal
- Sensors s1, s2, s3
- Grease lubrication
- Circular connector cc spindle side
- Taper cleaning

HX-2 18/12 24 3C

PRESTAZIONI / PERFORMANCES

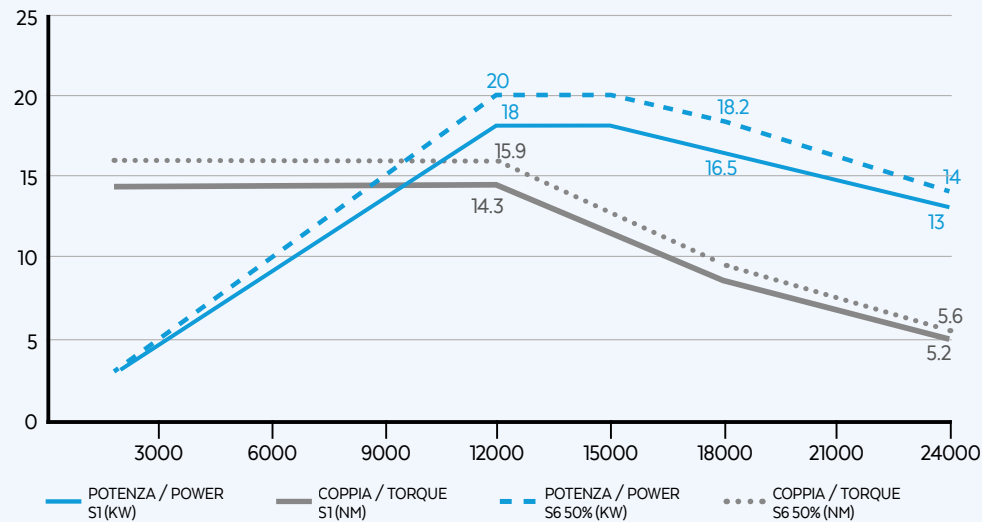

OPZIONALI / OPTIONALS

- Encoder 1Vpp or TTL
- Circular connector cc machine side
- Long nose
- Air tool
- Sensor s5
- Bearings temperature monitoring
- Speed monitoring
- Vibration sensor
- HSK 63E/63A
- Oil mist/MQL

SPECIFICHE TECNICHE / TECHNICAL SPECIFICATIONS

- S1-S6 kW** 18/20
- S1-S6 A** 35/38.5
- Pol es** 4
- S1-S6 Nm** 14.3/15.9
- Volt** 380
- Supply** inverter
- rpm** 24000
- kg** 25

EQUIPAGGIAMENTO / EQUIPMENT

- HSK 63F
- Liquid cooling
- Single effect pneumatic cylinder
- Automatic tool changer
- Ceramic ball bearings
- Labyrinth with air seal
- Sensors s1, s2, s3
- Grease lubrication
- Circular connector cc spindle side
- Taper cleaning

HX-2 20/10 24 3C (SYNCHRONOUS)

PRESTAZIONI / PERFORMANCES

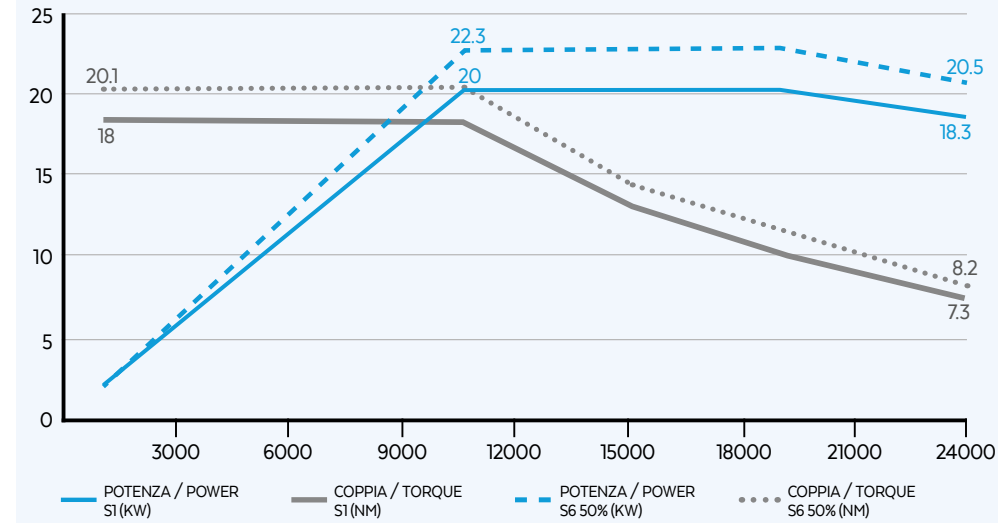

OPZIONALI / OPTIONALS

- Long nose
- Air tool
- Sensor s5
- Oil mist/MQL
- Circular connector cc machine side
- Bearings temperature monitoring
- Speed monitoring
- Vibration sensor
- HSK 63E

SPECIFICHE TECNICHE / TECHNICAL SPECIFICATIONS

- S1-S6 kW** 20/22.3
- S1-S6 A** 48/50
- Pol es** 4
- S1-S6 Nm** 17.8/20.1
- Volt** 380
- Supply** inverter
- rpm** 24000
- kg** 25

EQUIPAGGIAMENTO / EQUIPMENT

- HSK 63A
- Liquid cooling
- Single effect pneumatic cylinder
- Automatic tool changer
- Ceramic ball bearings
- Labyrinth with air seal
- Sensors s1, s2, s3
- Grease lubrication
- Circular connector cc spindle side
- Taper cleaning
- Encoder 1Vpp



ROBOTECH HD



SUITABLE FOR MACHINING ALUMINUM AND COMPOSITES
OPTIMAL DESIGN FOR BI-ROTARY HEADS (90°)
TWO INDEPENDENT TOOL LUBRICATION CHANNELS
ANTI-ROTATION PRESET FOR AGGREGATE CONNECTION
AVAILABLE WITH HSK 50F AND HSK 40E

HD-2 5.6/18 20

PRESTAZIONI / PERFORMANCES

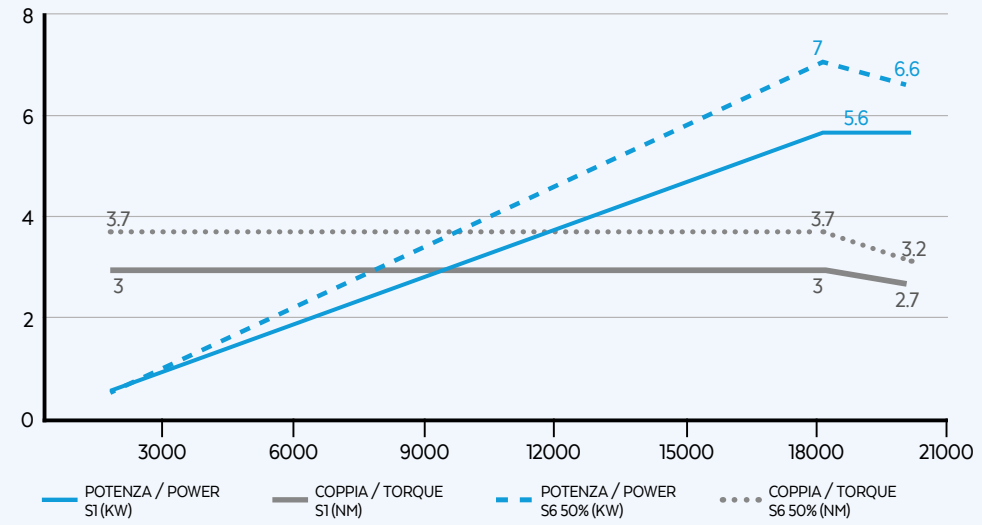

OPZIONALI / OPTIONALS

- Encoder TVpp or TTL
- Sensor s5
- HSK 40E

SPECIFICHE TECNICHE / TECHNICAL SPECIFICATIONS

- S1-S6 kW 5.6/7
- S1-S6 A 12/14
- Pol es 4
- S1-S6 Nm 3/3.7
- Volt 380
- Supply inverter
- rpm 20000
- kg 18

EQUIPAGGIAMENTO / EQUIPMENT

- HSK 50F
- Liquid cooling
- Single effect pneumatic cylinder
- Automatic tool changer
- Ceramic ball bearings
- Labyrinth with air seal
- Sensors s1, s2, s3
- Grease lubrication
- Taper cleaning

LAYOUT HSK 50F

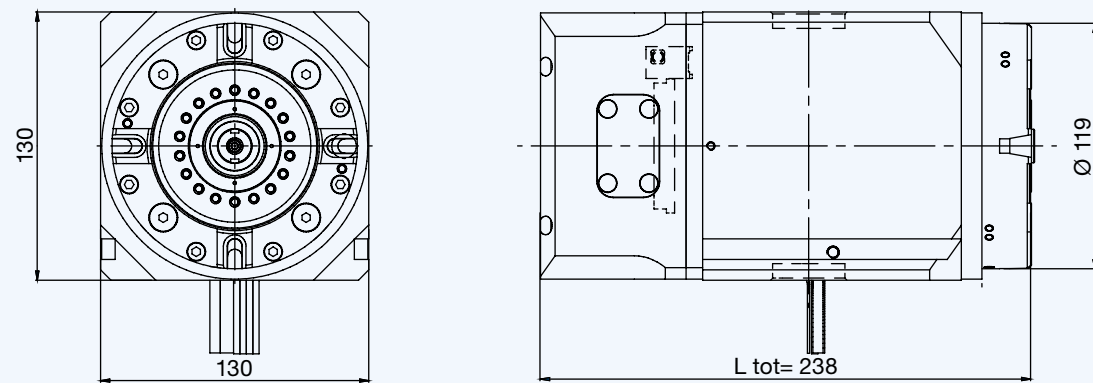

ROBOTECH
QT



SUITABLE FOR MACHINING WOODEN BEAMS
POWER UP TO 25 KW AND HIGH TORQUES FOR HEAVY MACHINING
OPTIMAL DESIGN FOR BI-ROTARY HEADS (50° AND 90°)
AVAILABLE WITH HSK 63E

LAYOUT HSK 63E

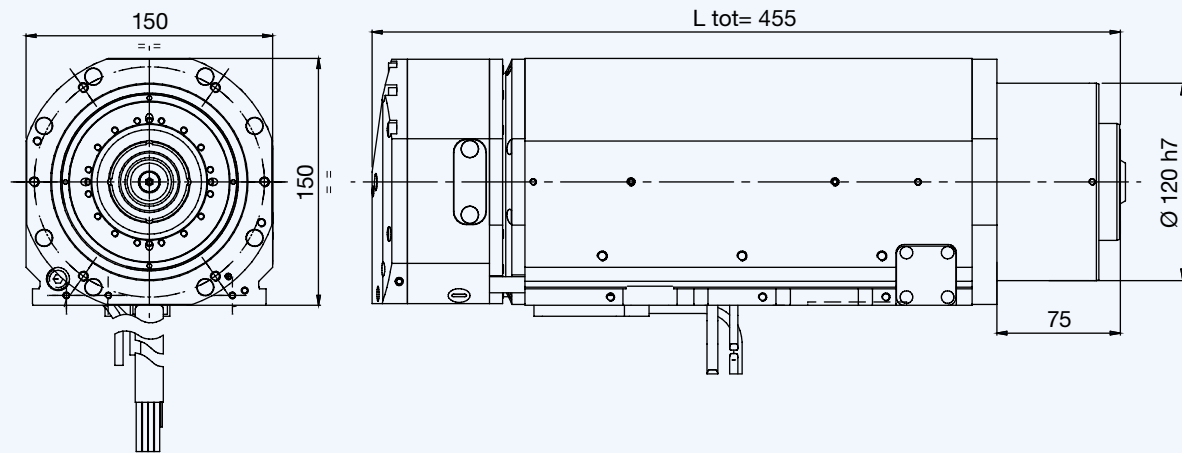

QT-2 13/6 16

LIQUID HIGH TORQUE

PRESTAZIONI / PERFORMANCES

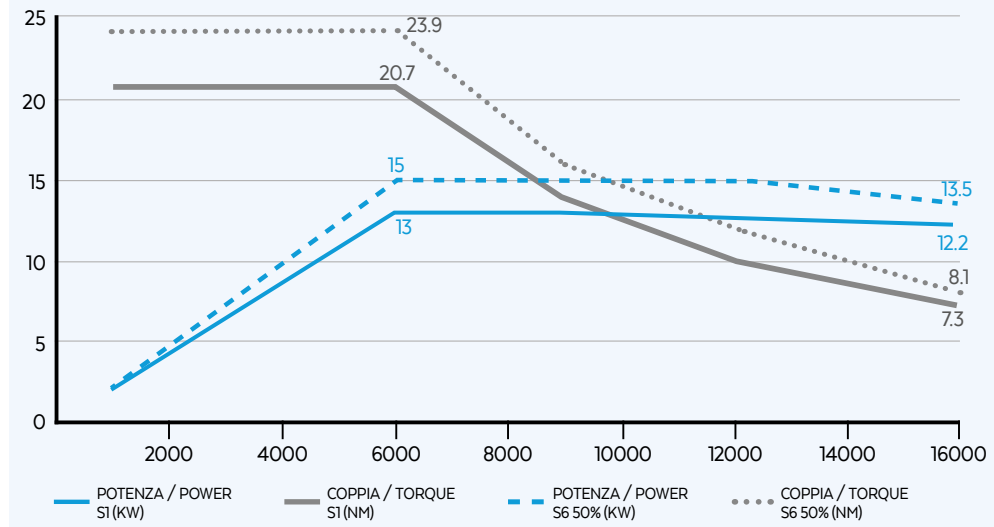

OPZIONALI / OPTIONALS



SPECIFICHE TECNICHE / TECHNICAL SPECIFICATIONS

S1-S6 kW 13/15	S1-S6 A 30/35	Pol es 4
S1-S6 Nm 20.7/23.9	Volt 400	Supply inverter
rpm 16000	kg 36	

EQUIPAGGIAMENTO / EQUIPMENT

HSK 63E	Liquid cooling	Single effect pneumatic cylinder	Automatic tool changer
Ceramic ball bearings	Labyrinth with air seal	Sensors S1, S2, S3, S5	Grease lubrication
Taper cleaning			

QT-2 25/7 16 (SYNCHRONOUS)

LIQUID HIGH TORQUE

PRESTAZIONI / PERFORMANCES

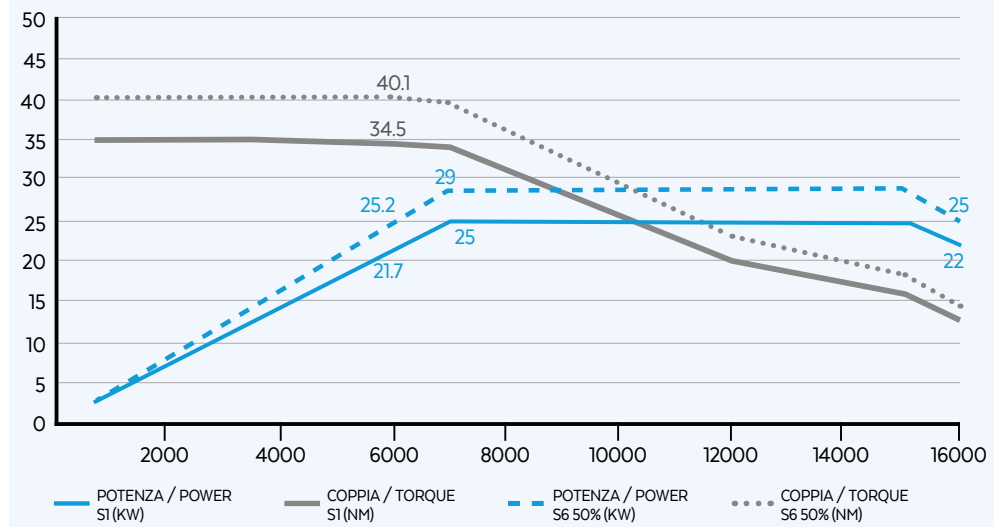

SPECIFICHE TECNICHE / TECHNICAL SPECIFICATIONS

S1-S6 kW 25/29	S1-S6 A 47/56	Pol es 4
S1-S6 Nm 34.5/40.1	Volt 400	Supply inverter
rpm 16000	kg 36	

EQUIPAGGIAMENTO / EQUIPMENT

HSK 63E	Liquid cooling	Single effect pneumatic cylinder	Automatic tool changer
Ceramic ball bearings	Labyrinth with air seal	Sensors S1, S2, S3, S5	Grease lubrication
Taper cleaning	Encoder TVpp or TTL		

ROBOTECH HT

SUITABLE FOR MACHINING WOOD AND ALUMINUM
POWER UP TO 25 KW AND HIGH TORQUES FOR HEAVY MACHINING
OPTIMAL DESIGN FOR 3 AND 5-AXIS MACHINES
AVAILABLE WITH ENCODER ON BOARD, LONG NOSE WITH 5 BEARINGS,
AIR TOOL, MQL AND OIL MIST AVAILABLE WITH HSK 63E



HT-2 25/10 24

PRESTAZIONI / PERFORMANCES

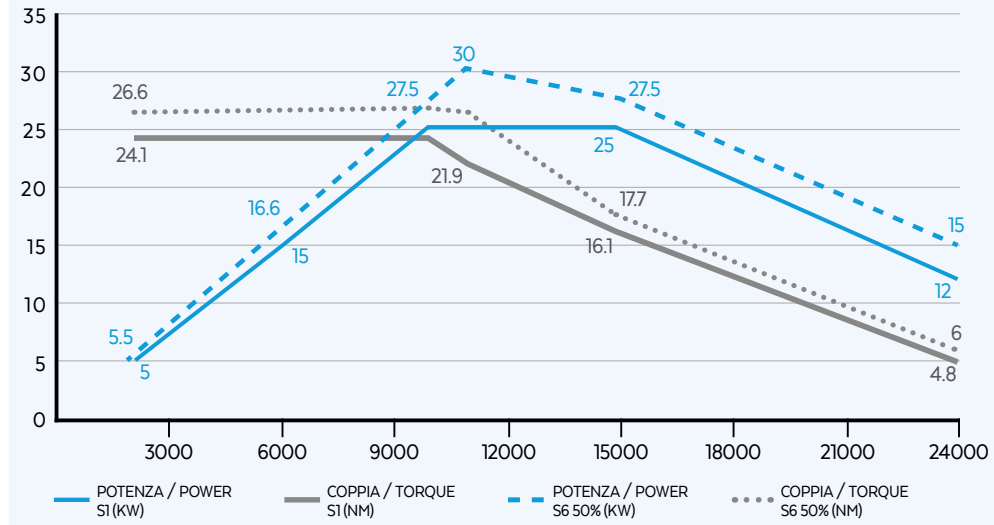

OPZIONALI / OPTIONALS

- Encoder TVpp or TTL
- Sensor s5
- Oil mist/MQL
- Circular connector cc machine side
- Bearings temperature monitoring
- Speed monitoring
- Vibration sensor
- Air tool
- HSK 63A

SPECIFICHE TECNICHE / TECHNICAL SPECIFICATIONS

- S1-S6 kW 25/30
- S1-S6 A 53/60
- Pol es 4
- S1-S6 Nm 24.2/26.6
- Volt 380
- Supply inverter
- rpm 24000
- kg 42

EQUIPAGGIAMENTO / EQUIPMENT

- HSK 63E
- Liquid cooling
- Single effect pneumatic cylinder
- Automatic tool changer
- Ceramic ball bearings
- Labyrinth with air seal
- Sensors s1, s2, s3
- Grease lubrication
- Circular connector cc spindle side
- Taper cleaning

LAYOUT HSK 63E

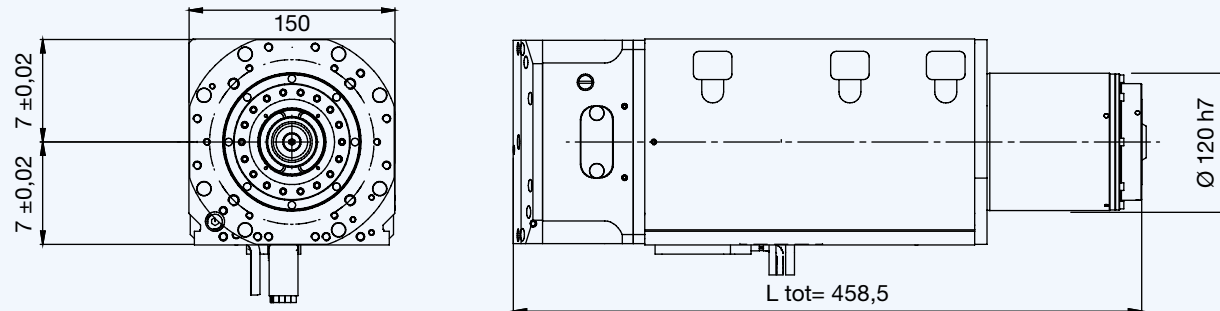

LAYOUT HSK 63E 3C

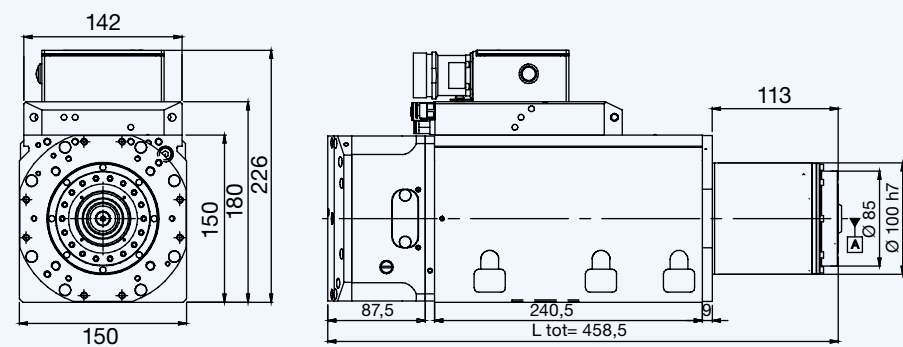

ROBOTECH QM



SUITABLE FOR INTENSE MACHINING OF WOOD, ALUMINUM AND LIGHT ALLOY
POWER UP TO 30 KW AND HIGH TORQUES
AVAILABLE WITH ENCODER ON BOARD, AIR TOOL, MQL AND OIL MIST
AVAILABLE WITH HSK 80F AND HSK 63A

LAYOUT HSK 63A

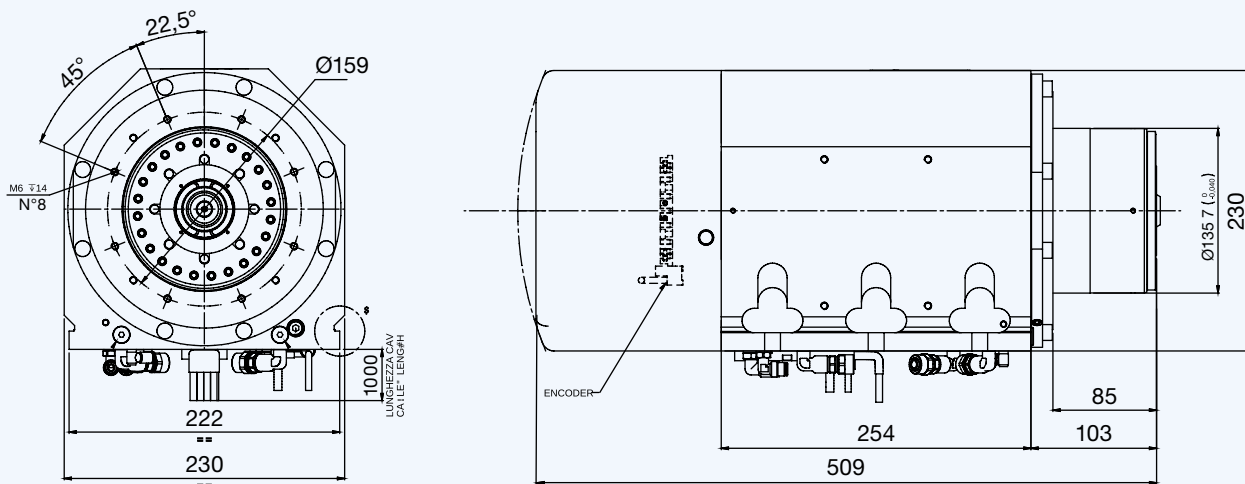

QM-2 30/6 13

HIGH TORQUE

PRESTAZIONI / PERFORMANCES

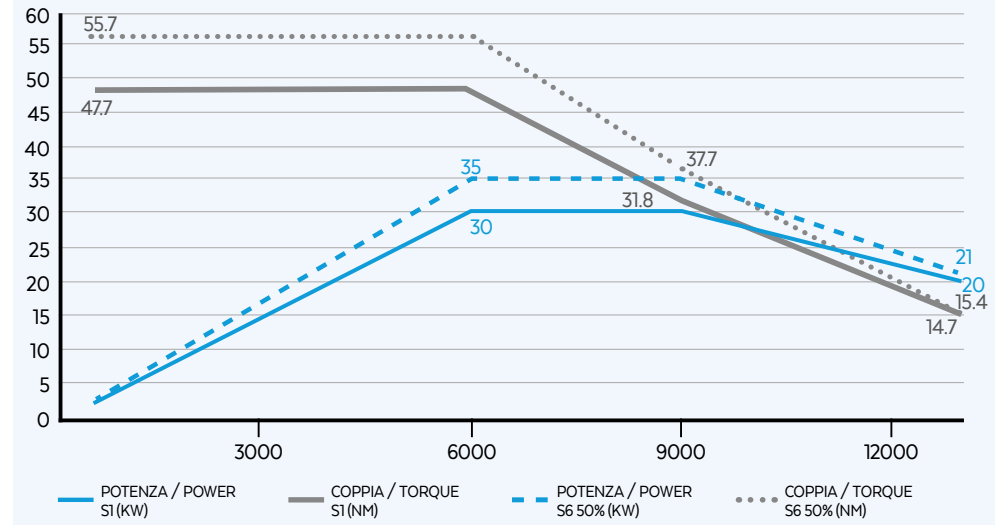

OPZIONALI / OPTIONALS

- Air tool
- Sensor s5
- Oil mist/MQL
- HSK 80F
- HSK 85S
- Bearings temperature monitoring
- Speed monitoring
- Vibration sensor
- Quick connection PP machine side

SPECIFICHE TECNICHE / TECHNICAL SPECIFICATIONS

- S1-S6 kW 30/35
- S1-S6 A 59/65
- Pol es 4
- S1-S6 Nm 47.7/55.7
- Volt 380
- Supply inverter
- rpm 13000
- kg 75

EQUIPAGGIAMENTO / EQUIPMENT

- HSK 63A
- Liquid cooling
- Single effect pneumatic cylinder
- Automatic tool changer
- Ceramic ball bearings
- Labyrinth with air seal
- Sensors s1, s2, s3
- Grease lubrication
- Quick connection pp spindle side
- Taper cleaning



CUSTOMTECH KX



SUITABLE FOR MACHINING METAL, ALUMINUM AND LIGHT ALLOY
POWER UP TO 32 KW AND HIGH TORQUES UP TO 100 NM
FRONT BEARING COOLING CIRCUIT
AVAILABLE WITH ENCODER ON BOARD, AIR TOOL, MQL, OIL MIST AND CTS
SYNCHRONOUS SPINDLES WITH HSK 63A AND ENCODER ON BOARD

LAYOUT HSK 63A

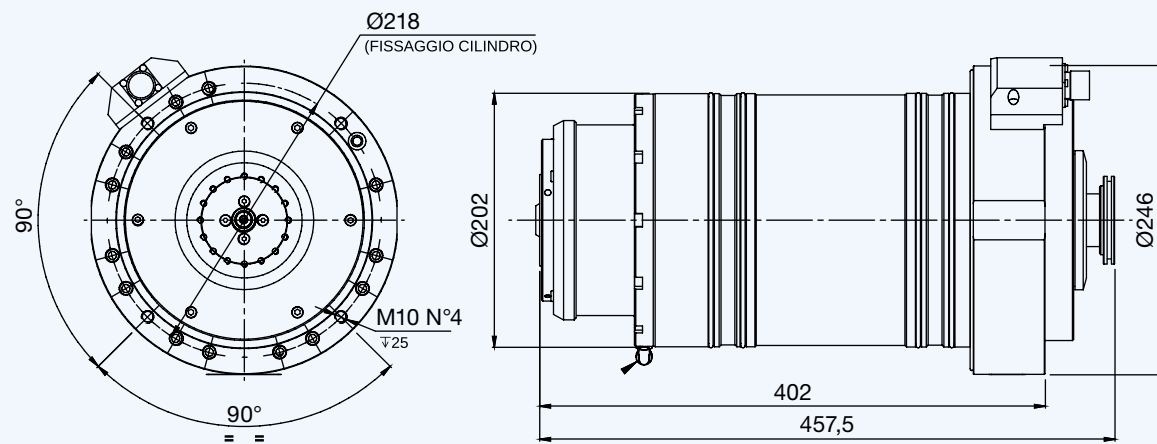

ALTRI LAYOUT / OTHER LAYOUTS

	ΔL	L tot
NL*	+58 mm	515 mm

KX-2 31/3 15

PRESTAZIONI / PERFORMANCES

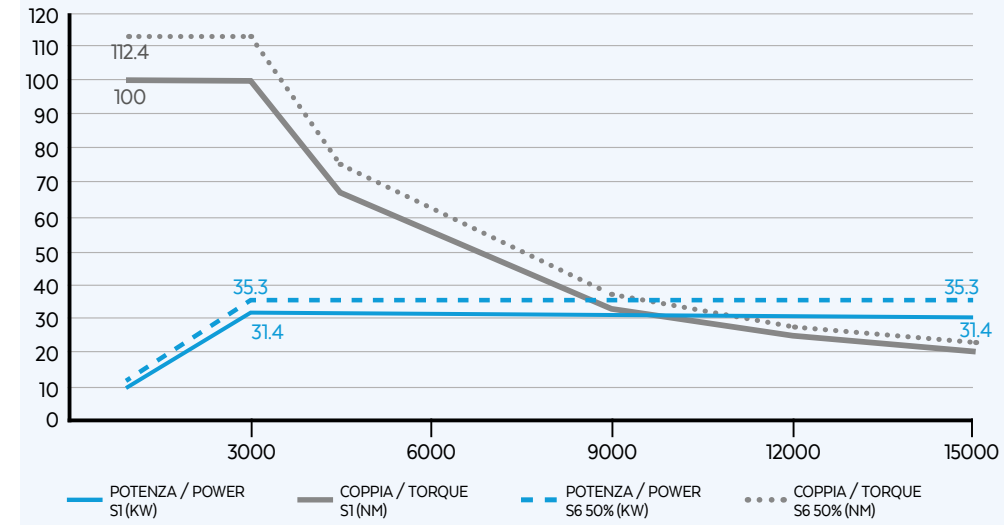

OPZIONALI / OPTIONALS

- Taper cleaning
- Air tool
- Water tool cooling
- CTS lubrication
- Oil mist/MQL
- Temperature sensor

SPECIFICHE TECNICHE / TECHNICAL SPECIFICATIONS

- S1-S6 kW 31/35.3
- S1-S6 Nm 68/100
- S1-S6 rpm 15000
- S1-S6 A 73/113
- Volt 400
- kg 100
- Pol es 4
- Supply inverter

EQUIPAGGIAMENTO / EQUIPMENT

- HSK 63A
- Ceramic ball bearings
- Encoder 1Vpp
- Liquid cooling
- Labyrinth with air seal
- Single effect pneumatic cylinder
- Sensors s1, s2
- Automatic tool changer
- Grease lubrication

KX-2 32/4.5 24

PRESTAZIONI / PERFORMANCES

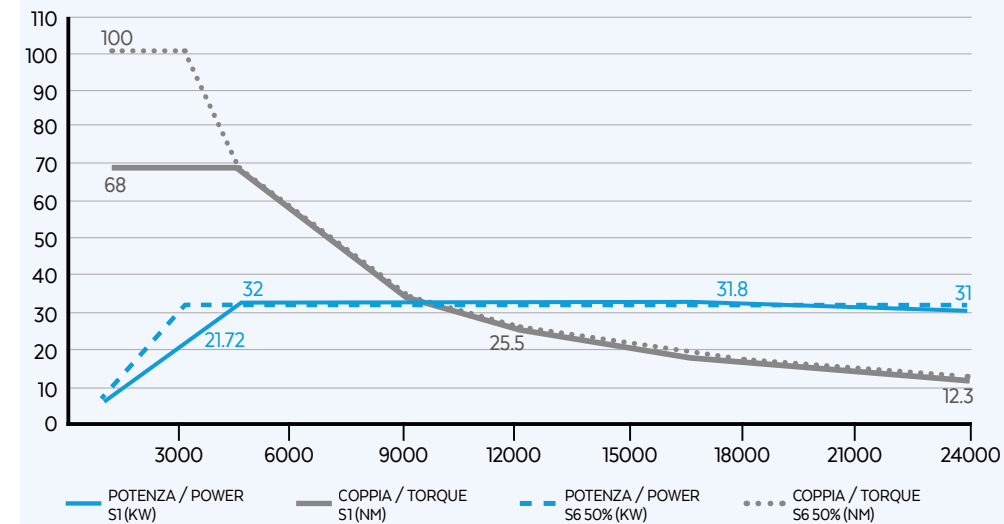

OPZIONALI / OPTIONALS

- Taper cleaning
- Air tool
- Long nose
- Temperature sensor
- CTS lubrication
- Oil mist/MQL
- Water tool cooling

SPECIFICHE TECNICHE / TECHNICAL SPECIFICATIONS

- S1-S6 kW 32/32
- S1-S6 Nm 68/100
- S1-S6 rpm 24000
- S1-S6 A 73/113
- Volt 400
- kg 100
- Pol es 4
- Supply inverter

EQUIPAGGIAMENTO / EQUIPMENT

- HSK 63A
- Ceramic ball bearings
- Encoder 1Vpp
- Liquid cooling
- Labyrinth with air seal
- Single effect pneumatic cylinder
- Sensors s1, s2
- Automatic tool changer
- Grease lubrication

CUSTOMTECH MG



SUITABLE FOR MACHINING GLASS AND MARBLE
POWER UP TO 30 KW AND HIGH TORQUES UP TO 39 NM
AVAILABLE WITH CASE AND CTS
ISO 40 TAPER

LAYOUT ISO 40

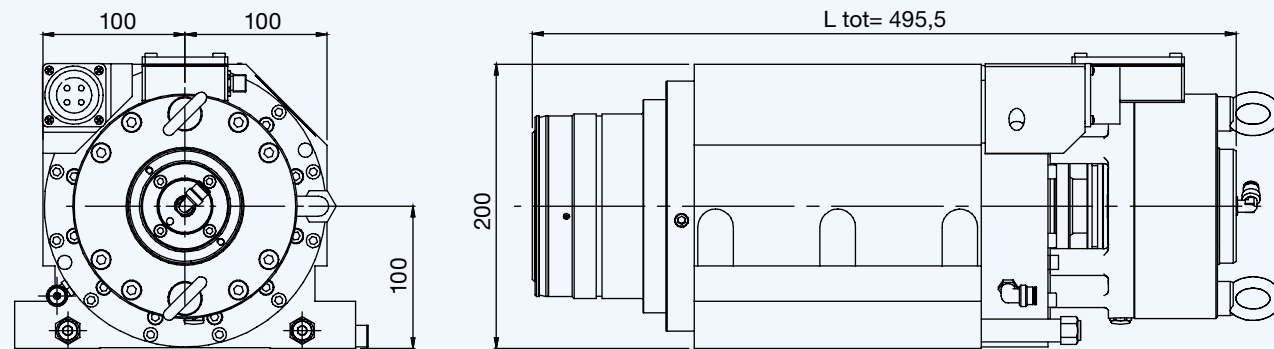

MG-2 9/6 15

PRESTAZIONI / PERFORMANCES

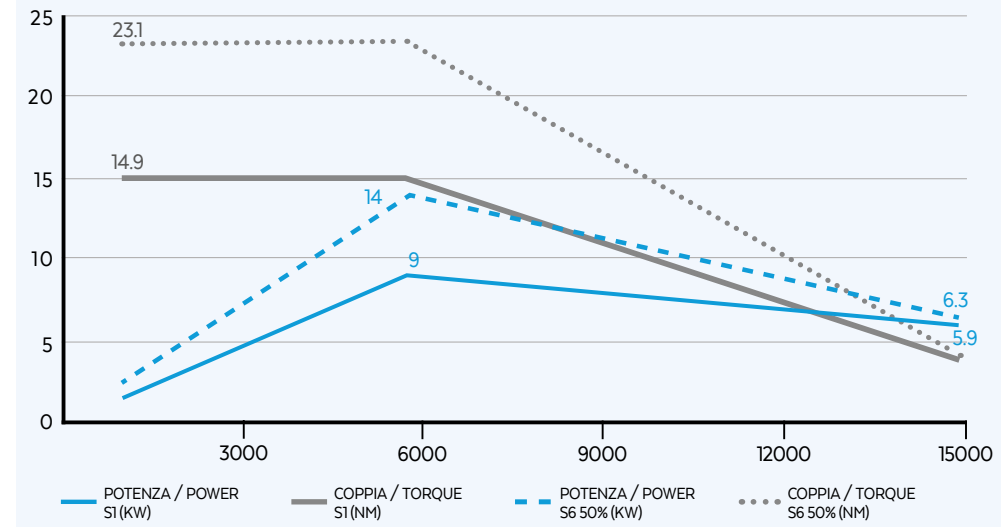

OPZIONALI / OPTIONALS

- CTS lubrication
- Air tool
- Oil mist/MQL
- Water tool cooling

SPECIFICHE TECNICHE / TECHNICAL SPECIFICATIONS

- S1-S6 kW** 9/14
- S1-S6 Nm** 14.9/23.1
- S1-S6 A** 24/33
- Volt** 380
- rpm** 15000
- kg** 90
- Pol es** 4
- Supply** inverter

EQUIPAGGIAMENTO / EQUIPMENT

- ISO 40
- Liquid cooling
- Single effect cylinder
- Automatic tool changer
- Ceramic ball bearings
- Labyrinth with air seal
- Sensors s1, s2
- Grease lubrication
- Taper cleaning

MG-2 13.5/6 15

PRESTAZIONI / PERFORMANCES

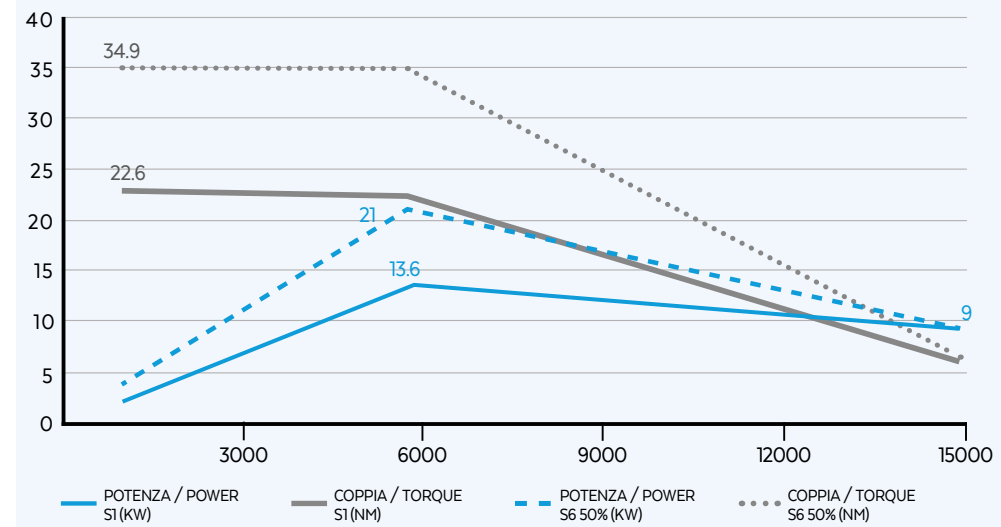

OPZIONALI / OPTIONALS

- CTS lubrication
- Air tool
- Oil mist/MQL

SPECIFICHE TECNICHE / TECHNICAL SPECIFICATIONS

- S1-S6 kW** 13.6/21
- S1-S6 Nm** 22.6/34.9
- S1-S6 A** 32/34.9
- Volt** 380
- rpm** 15000
- kg** 90
- Pol es** 4
- Supply** inverter

EQUIPAGGIAMENTO / EQUIPMENT

- ISO 40
- Liquid cooling
- Single effect cylinder
- Automatic tool changer
- Ceramic ball bearings
- Labyrinth with air seal
- Sensors s1, s2
- Grease lubrication
- Taper cleaning

MG 30/7.5 12

PRESTAZIONI / PERFORMANCES

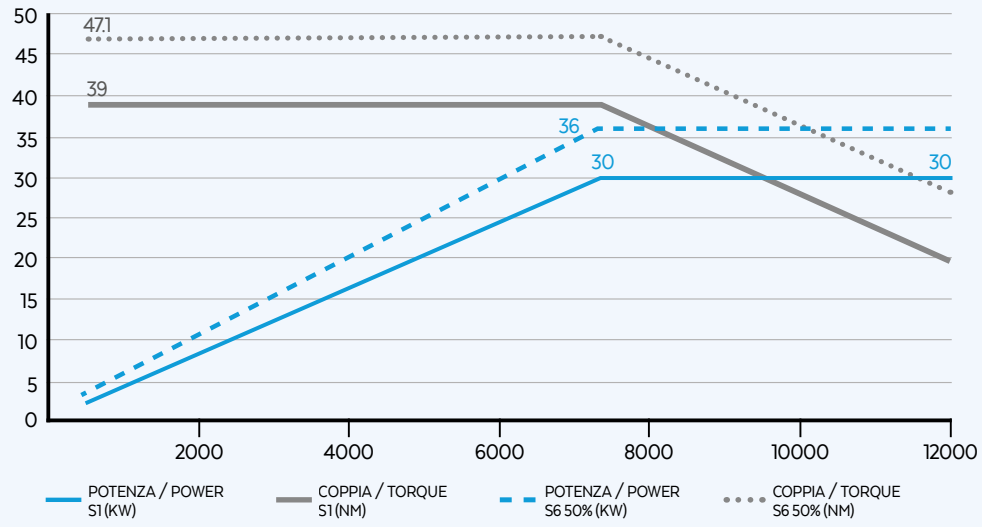

OPZIONALI / OPTIONALS

- CTS Lubrication
- Air tool
- Oil mist/MQL
- Water tool cooling

SPECIFICHE TECNICHE / TECHNICAL SPECIFICATIONS

- S1-S6 kW** 30/36
- S1-S6 A** 66/78
- Pol es** 4
- S1-S6 Nm** 39/47.1
- Volt** 380
- Supply** inverter
- rpm** 12000
- kg** 73

EQUIPAGGIAMENTO / EQUIPMENT

- ISO 40
- Liquid cooling
- Single effect cylinder
- Automatic tool changer
- Ceramic ball bearings
- Labyrinth with air seal
- Sensors s1, s2
- Grease lubrication
- Taper cleaning



MULTITECH
MA



SUITABLE FOR MACHINING LATEST MATERIALS IN DUST ENVIRONMENTS
EASY ASSEMBLING ON 3 AND 5-AXIS MACHINES
VERY EFFICIENT COMPRESSED AIR COOLING
AVAILABLE WITH ER 32

MA-1C 7.5/12 24

DOUBLE SIDE

PRESTAZIONI / PERFORMANCES

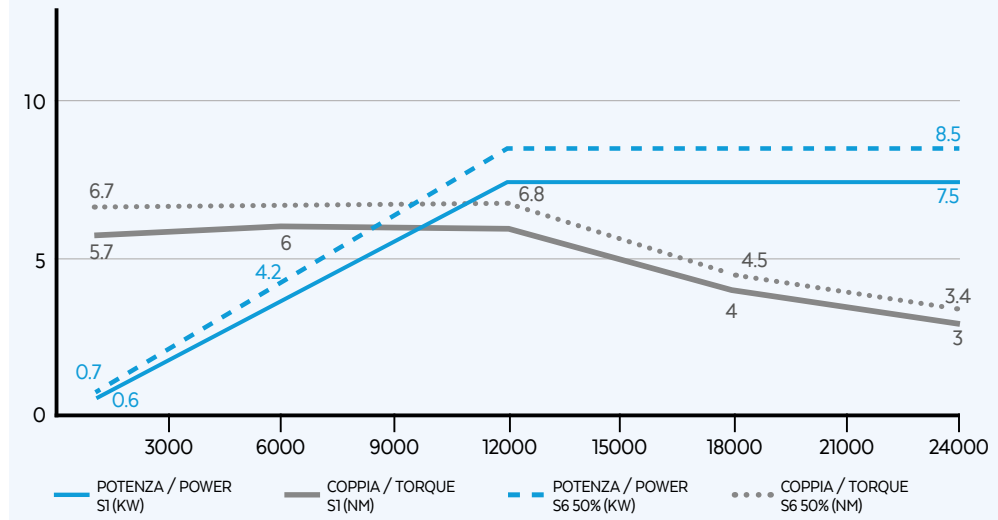

SPECIFICHE TECNICHE / TECHNICAL SPECIFICATIONS

- S1-S6 kW** 7.5/8.5
- S1-S6 A** 16/17
- Pol es** 4
- S1-S6 Nm** 6/6.8
- Volt** 380
- Supply** inverter
- rpm** 24000
- kg** 22

EQUIPAGGIAMENTO / EQUIPMENT

- Ceramic ball bearings**
- COMPRESSED AIR** Pressed air cooling
- Manual tool changer**
- ER 32DX/SX**
- Labyrinth with air seal**
- Grease lubrication**

LAYOUT ER32 DX-SX

DOUBLE SIDE

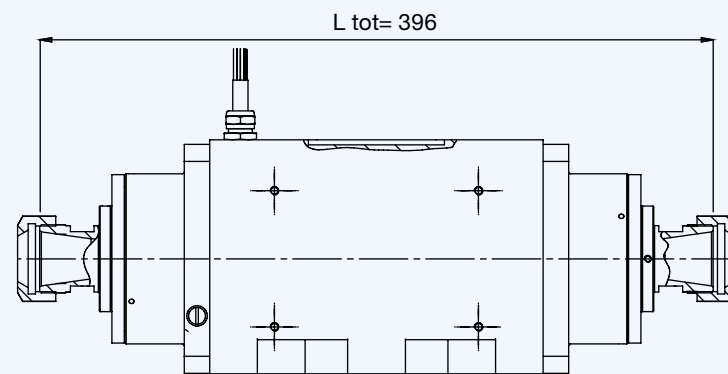
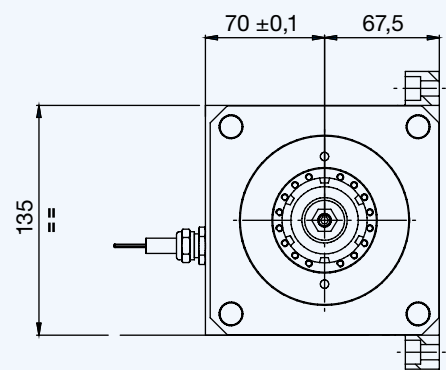

MULTITECH ML

SUITABLE FOR MACHINING LATEST MATERIALS IN DUST ENVIRONMENTS
EASY ASSEMBLING ON 3 AND 5-AXIS MACHINES
VERY EFFICIENT COMPRESSED AIR COOLING
AVAILABLE WITH ER 32 AND ER 40



LAYOUT ER32

SINGLE SIDE

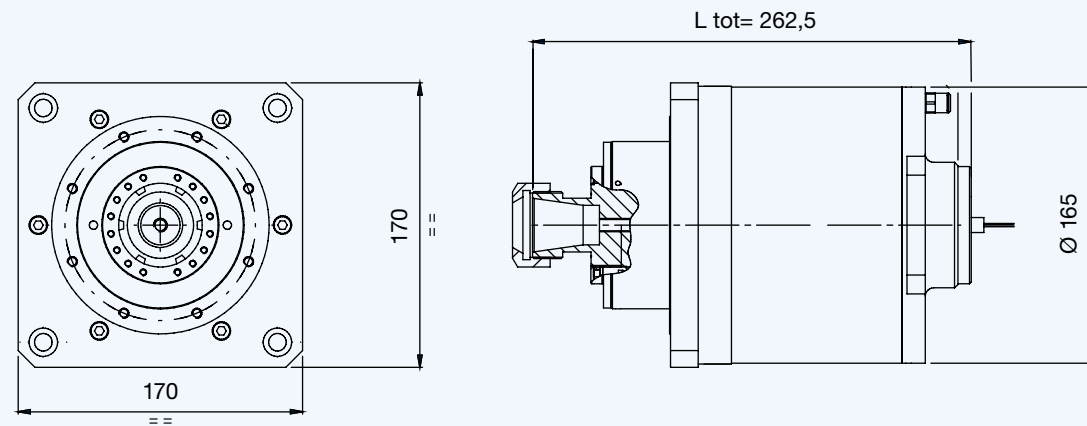

ML-1C 7.5/12 24

SINGLE SIDE

PRESTAZIONI / PERFORMANCES

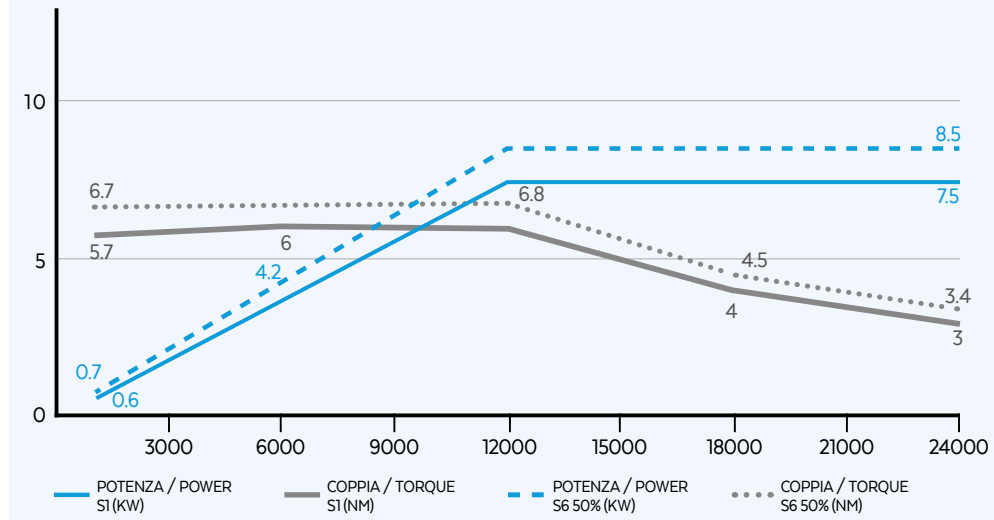

OPZIONALI / OPTIONALS



SPECIFICHE TECNICHE / TECHNICAL SPECIFICATIONS

S1-S6 kW 7.5/8.5	S1-S6 A 16/17	Pol es 4
S1-S6 Nm 6/6.8	Volt 380	Sup ply inverter
rpm 24000	kg 22	

EQUIPAGGIAMENTO / EQUIPMENT

Ceramic ball bearings	Pressed air cooling	Manual tool changer	Grease lubrication
ER 32 DX	Labyrinth with air seal		

ML-1C 10/12 24

SINGLE SIDE

PRESTAZIONI / PERFORMANCES

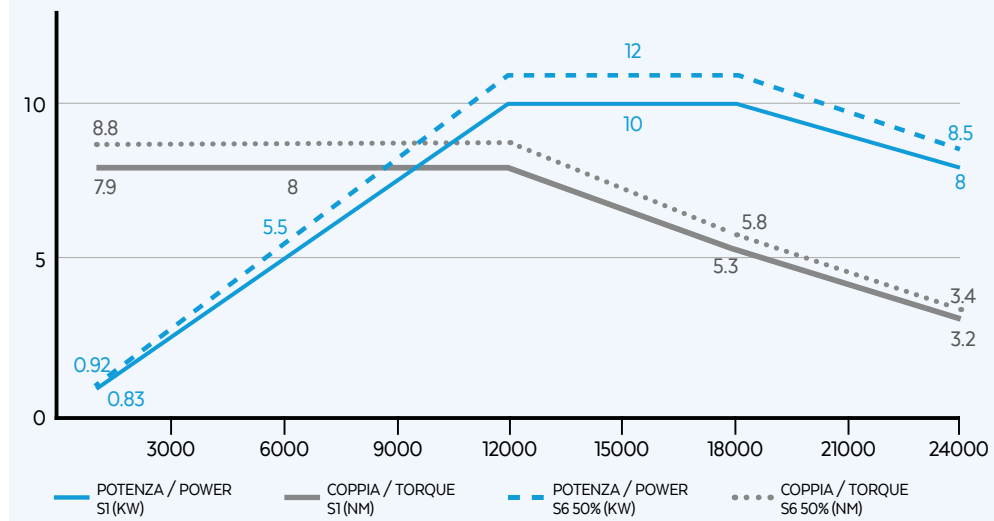

OPZIONALI / OPTIONALS



SPECIFICHE TECNICHE / TECHNICAL SPECIFICATIONS

S1-S6 kW 10/10.5	S1-S6 A 21.3/22	Pol es 4
S1-S6 Nm 8/8.8	Volt 380	Sup ply inverter
rpm 24000	kg 22	

EQUIPAGGIAMENTO / EQUIPMENT

Ceramic ball bearings	Pressed air cooling	Manual tool changer	Grease lubrication
ER 32 DX	Labyrinth with air seal		

MULTITECH ML

SUITABLE FOR MACHINING LATEST MATERIALS IN DUST ENVIRONMENTS
EASY ASSEMBLING ON 3 AND 5-AXIS MACHINES
VERY EFFICIENT COMPRESSED AIR COOLING
AVAILABLE WITH ER 32 AND ER 40



LAYOUT ER 40 DX-SX

DOUBLE SIDE

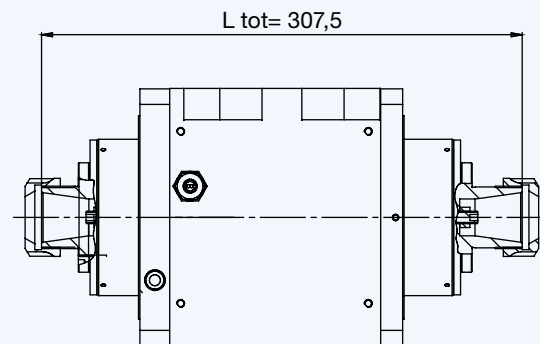
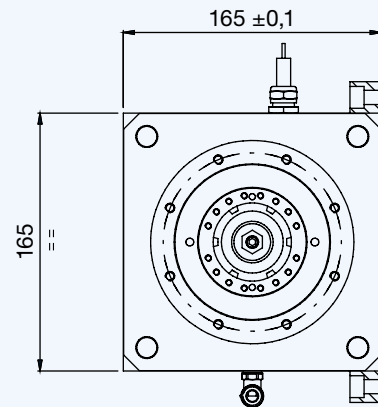

ML-1C 7.5/12 24

DOUBLE SIDE

PRESTAZIONI / PERFORMANCES

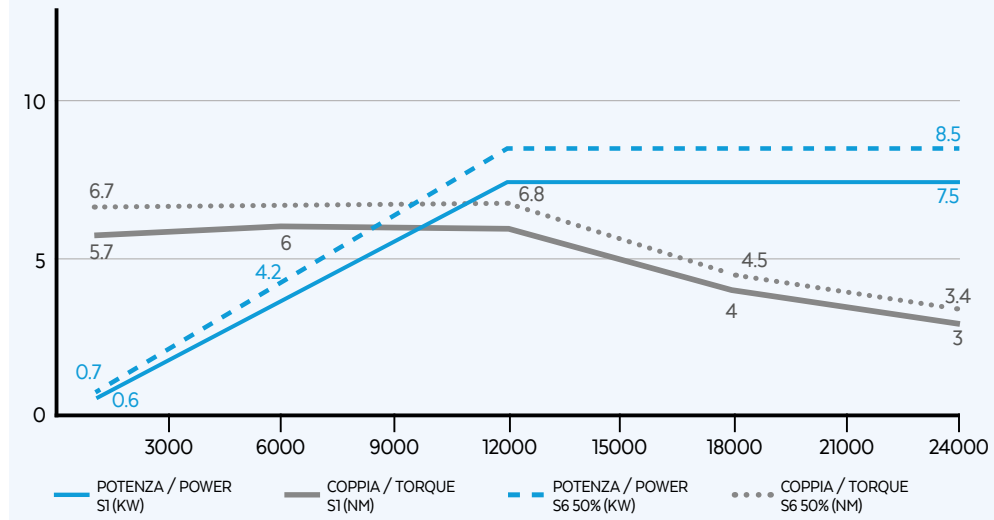

OPZIONALI / OPTIONALS

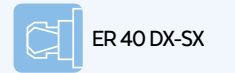

SPECIFICHE TECNICHE / TECHNICAL SPECIFICATIONS

S1-S6 kW 7.5/8.5
S1-S6 Nm 6/6.8
rpm 24000
S1-S6 A 16/17
Volt 380
kg 22
Pol es 4
Supply inverter

EQUIPAGGIAMENTO / EQUIPMENT

Ceramic ball bearings
COMPRESSED AIR Pressed air cooling
ER 32 DX-SX
Labyrinth with air seal
Manual tool changer
Grease lubrication

ML-1C 10/12 24

DOUBLE SIDE

PRESTAZIONI / PERFORMANCES

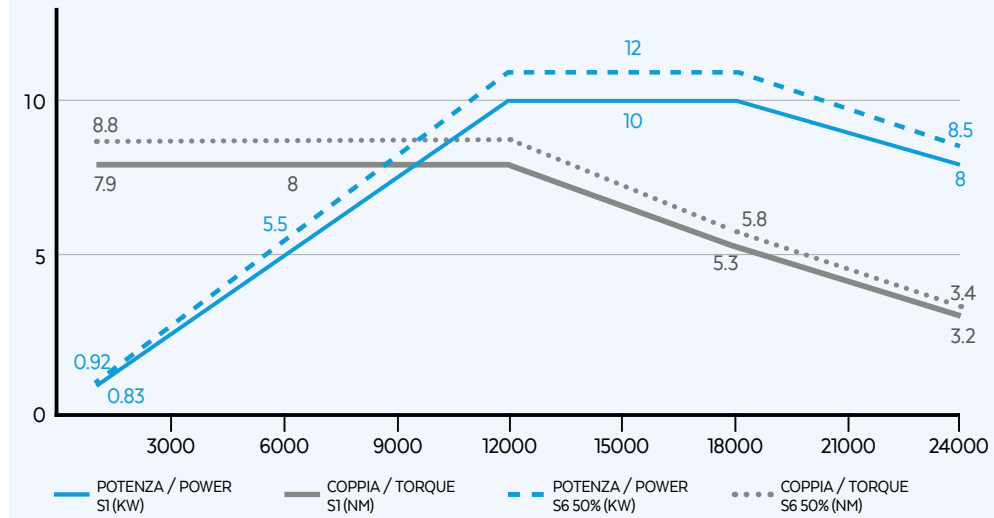

OPZIONALI / OPTIONALS



SPECIFICHE TECNICHE / TECHNICAL SPECIFICATIONS

S1-S6 kW 10/10.5
S1-S6 Nm 8/8.8
rpm 24000
S1-S6 A 21.3/22
Volt 380
kg 22
Pol es 4
Supply inverter

EQUIPAGGIAMENTO / EQUIPMENT

Ceramic ball bearings
COMPRESSED AIR Pressed air cooling
ER 32 DX-SX
Labyrinth with air seal
Manual tool changer
Grease lubrication

MULTITECH ML

SUITABLE FOR MACHINING LATEST MATERIALS IN DUST ENVIRONMENTS
EASY ASSEMBLING ON 3 AND 5-AXIS MACHINES
AVAILABLE WITH LIQUID COOLING TO FOR HEAVY AND INTENSIVE PROCESSES
AVAILABLE WITH ER 32 AND ER 40



ML-2 9.5/12 24

SINGLE SIDE

PRESTAZIONI / PERFORMANCES

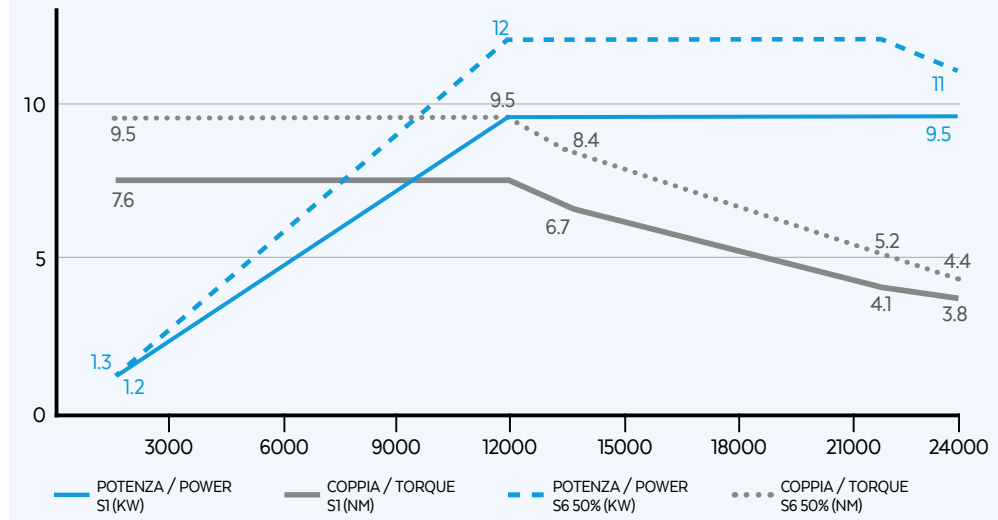

SPECIFICHE TECNICHE / TECHNICAL SPECIFICATIONS

S1-S6 kW 9.5/12	S1-S6 A 22/27	Pol es 4
S1-S6 Nm 7.6/9.5	Volt 380	Supply inverter
rpm 24000	kg 26	

EQUIPAGGIAMENTO / EQUIPMENT

Ceramic ball bearings	Liquid cooling	Manual tool changer	Grease lubrication
ER 40DX	Labyrinth with air seal		

LAYOUT ER 40DX

SINGLE SIDE

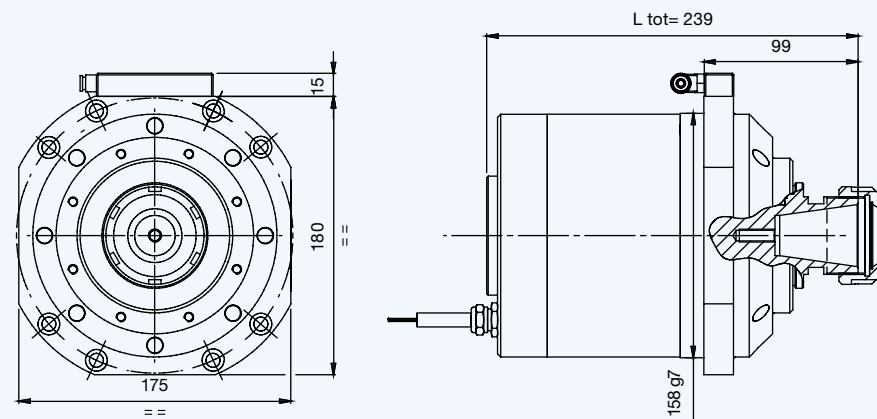

MULTITECH ML

SUITABLE FOR MACHINING LATEST MATERIALS IN DUST ENVIRONMENTS
EASY ASSEMBLING ON 3 AND 5-AXIS MACHINES
AVAILABLE WITH LIQUID COOLING TO FOR HEAVY AND INTENSIVE PROCESSES
AVAILABLE WITH ER 32 AND ER 40



ML-2 9.5/12 24

DOUBLE SIDE

PRESTAZIONI / PERFORMANCES

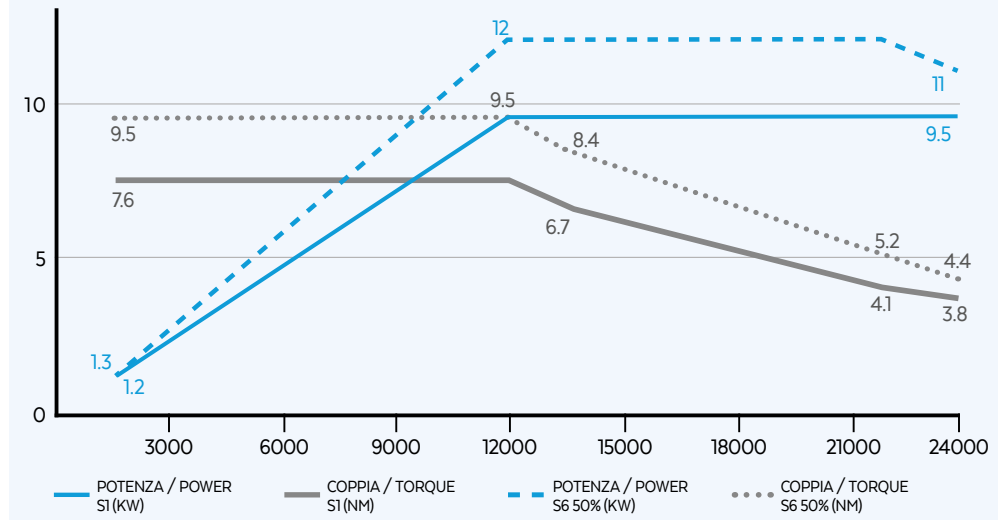

SPECIFICHE TECNICHE / TECHNICAL SPECIFICATIONS

S1-S6 kW 9.5/12	S1-S6 A 22/27	Pol es 4
S1-S6 Nm 7.6/9.5	Volt 380	Supply inverter
rpm 24000	kg 26	

EQUIPAGGIAMENTO / EQUIPMENT

- Ceramic ball bearings
- Liquid cooling
- Manual tool changer
- Grease lubrication
- ER 40 DX-SX
- Labyrinth with air seal

LAYOUT ER 40 DX-SX

DOUBLE SIDE

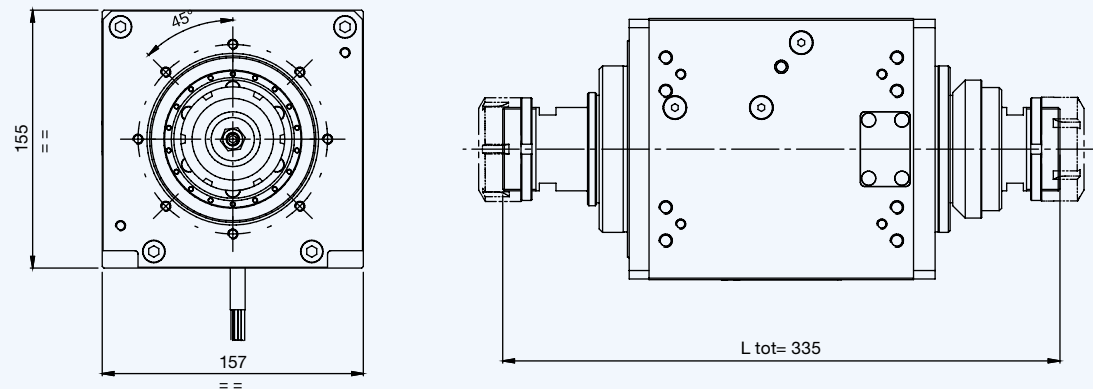

MULTITECH
XS



SUITABLE FOR MACHINING WOOD
EFFICIENT COOLING AND LOW NOISE LEVEL
SHAFT ROTATION SENSOR

LAYOUT D16 L13 - 0.35 KW

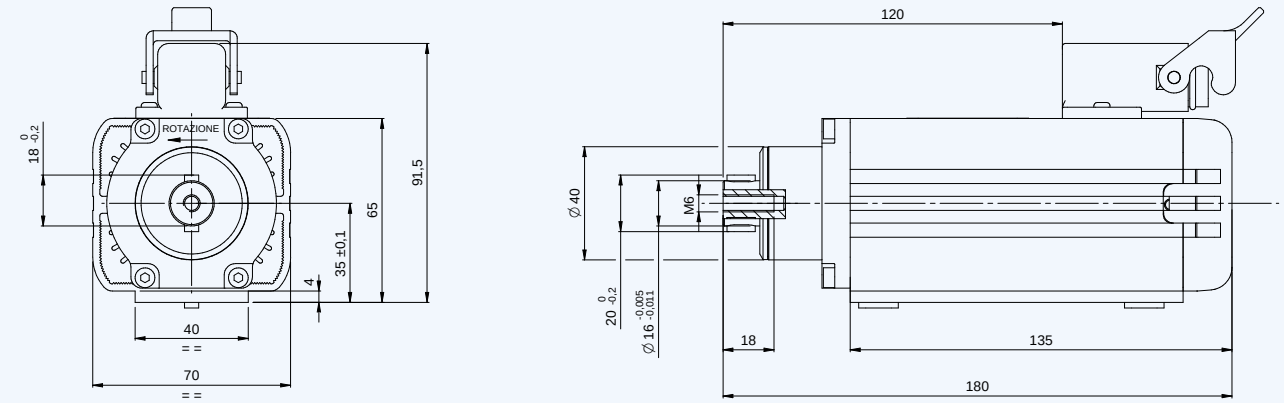

XS-1 0.35/12 12

PRESTAZIONI / PERFORMANCES

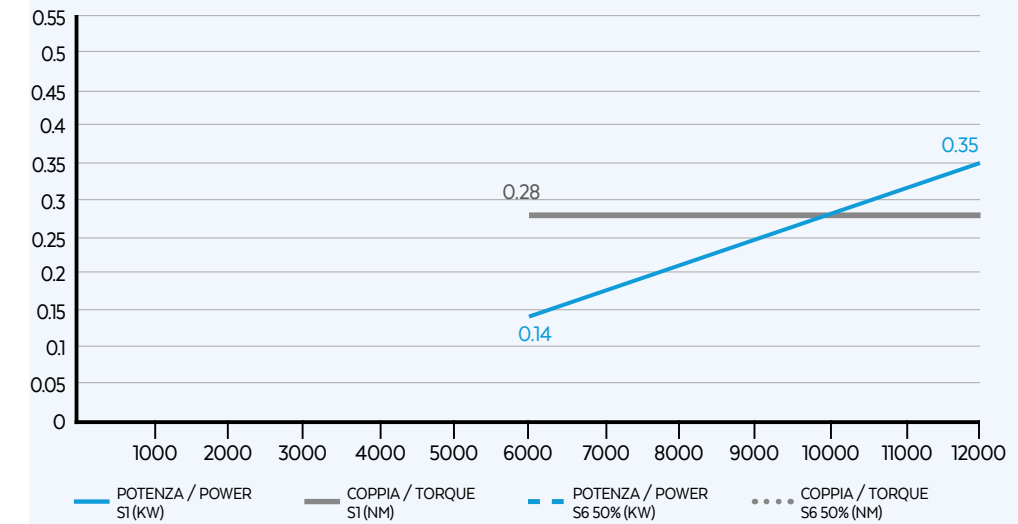

SPECIFICHE TECNICHE / TECHNICAL SPECIFICATIONS

S1 kW 0.35	S1 A 1.8	Pol es 2
S1 Nm 0.28	Volt 220	Sup ply inverter
rpm 12000	kg 2.7	

EQUIPAGGIAMENTO / EQUIPMENT

Shaft D16	Air fan shaft	Manual tool changer
Steel bearings	Grease lubrication	

LAYOUT D16 L13 - 0.55 KW

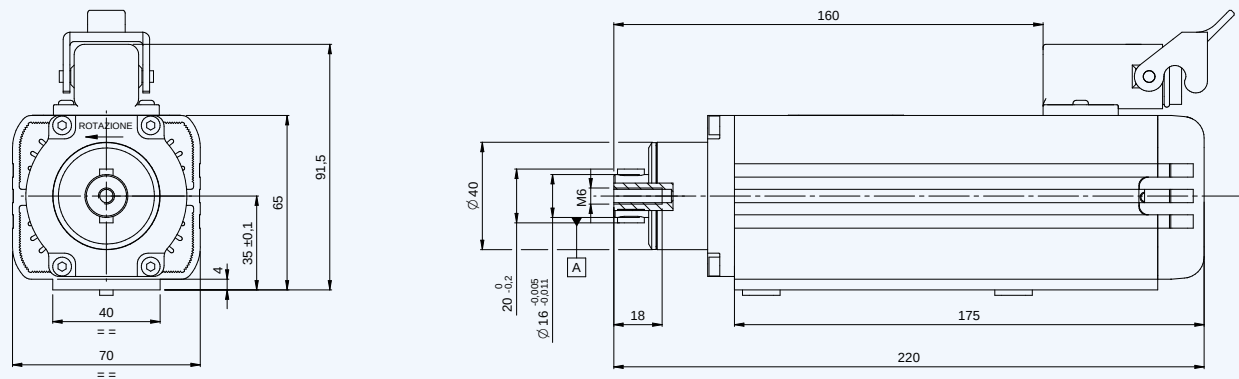

LAYOUT D16 L13 - 0.65 KW

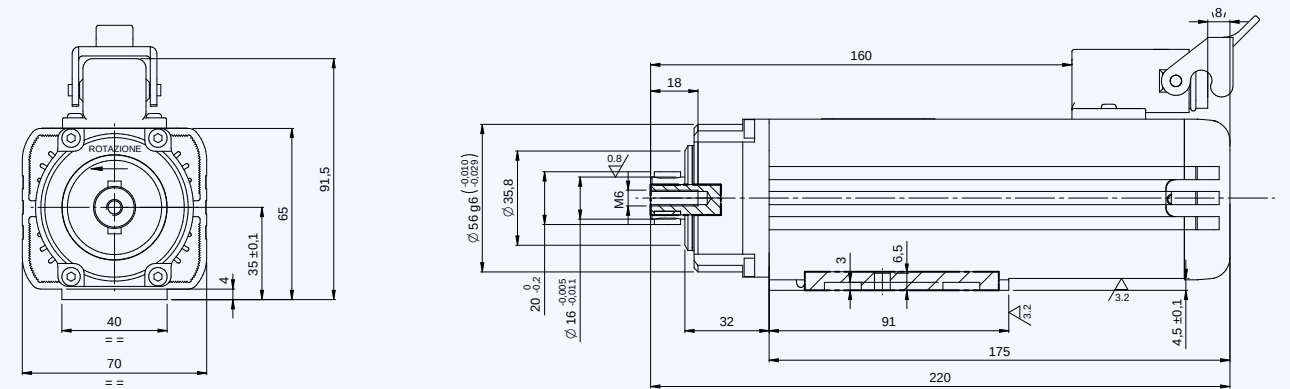

XS-1 0.55/12 12

PRESTAZIONI / PERFORMANCES

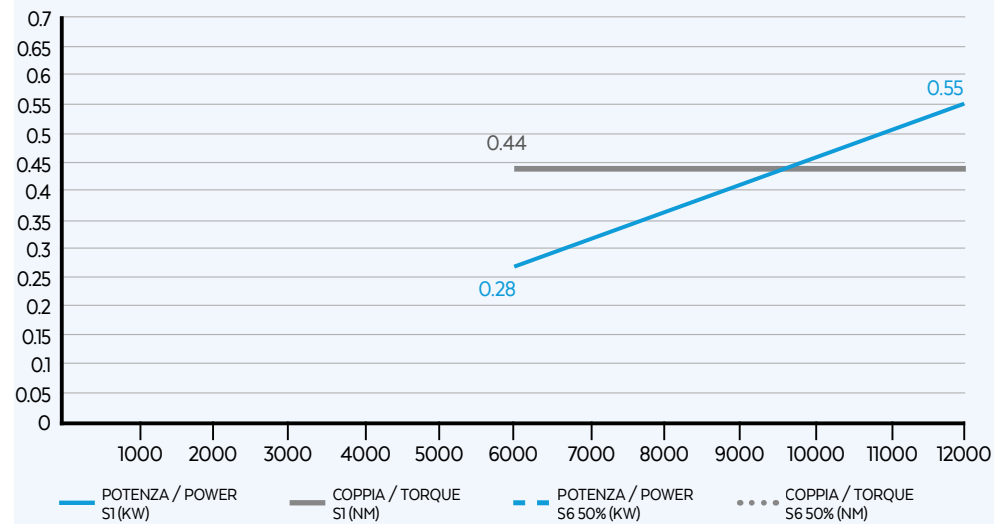

SPECIFICHE TECNICHE / TECHNICAL SPECIFICATIONS

S1 kW 0.55	S1 A 2.7	Pol es 2
S1 Nm 0.44	Volt 220	Sup ply inverter
rpm 12000	kg 3.2	

EQUIPAGGIAMENTO / EQUIPMENT

Shaft D16	Air fan shaft	Manual tool changer
Steel bearings	Grease lubrication	

XS-1 0.65/12 12

PRESTAZIONI / PERFORMANCES

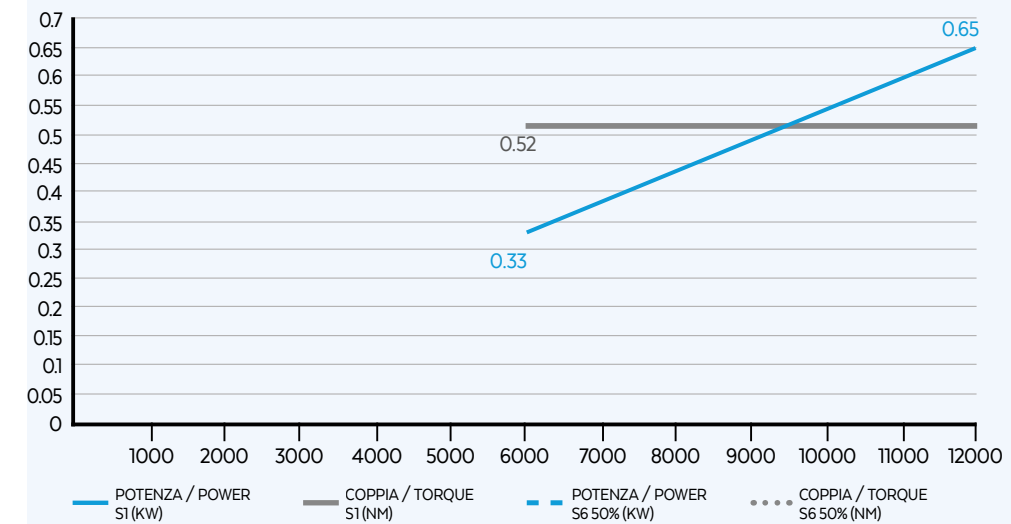

SPECIFICHE TECNICHE / TECHNICAL SPECIFICATIONS

S1 kW 0.65	S1 A 3	Pol es 2
S1 Nm 0.52	Volt 220	Sup ply inverter
rpm 12000	kg 3.3	

EQUIPAGGIAMENTO / EQUIPMENT

Shaft D16	Air fan shaft	Manual tool changer
Steel bearings	Grease lubrication	

MULTITECH
S

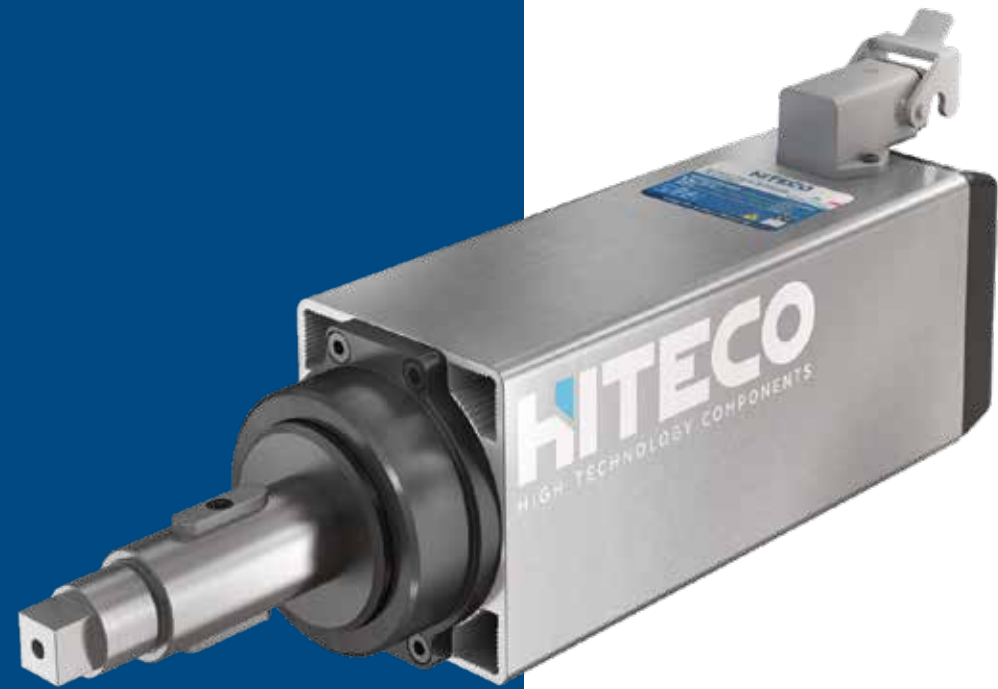

SUITABLE FOR MACHINING WOOD
EFFICIENT COOLING AND LOW NOISE LEVEL
SHAFT ROTATION SENSOR

LAYOUT D12 L 19 - 0.19 KW

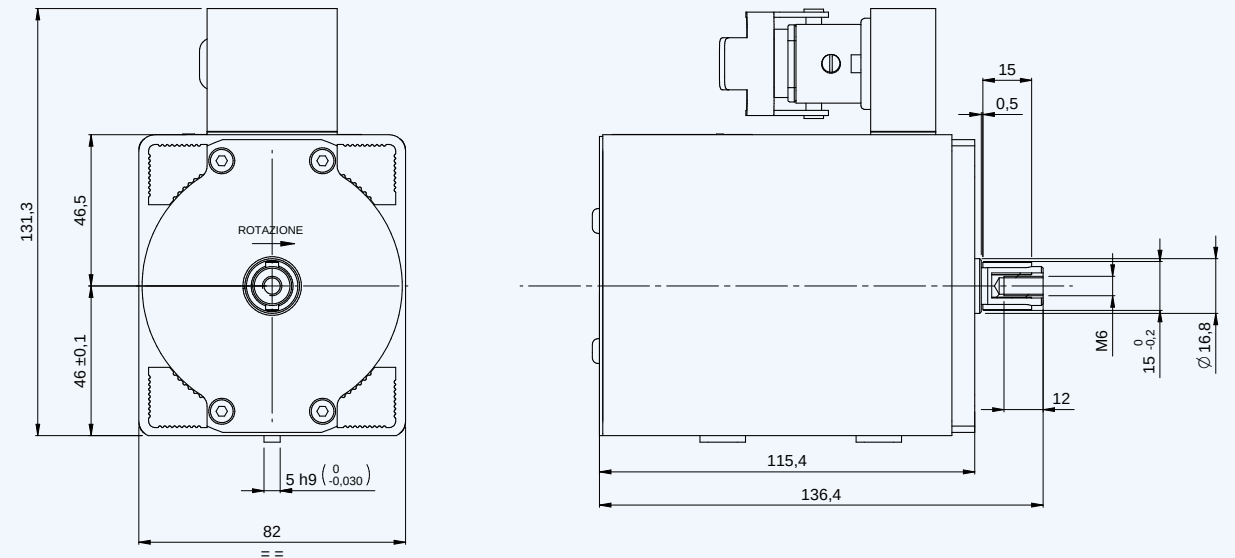

S-1 0.19/12 12

PRESTAZIONI / PERFORMANCES

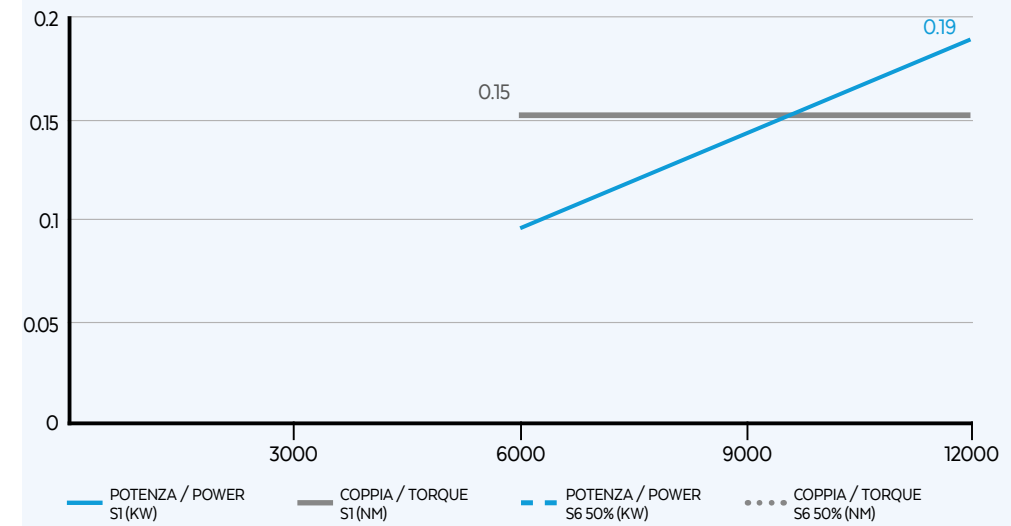

SPECIFICHE TECNICHE / TECHNICAL SPECIFICATIONS

S1 kW 0.19	S1 A 1.4	Pol es 2
S1 Nm 0.15	Volt 220	Sup ply inverter
rpm 12000	kg 2	

EQUIPAGGIAMENTO / EQUIPMENT

Shaft D12	Air fan shaft	Manual tool changer
Steel bearings	Grease lubrication	

LAYOUT D30 L58 - 1.5 KW

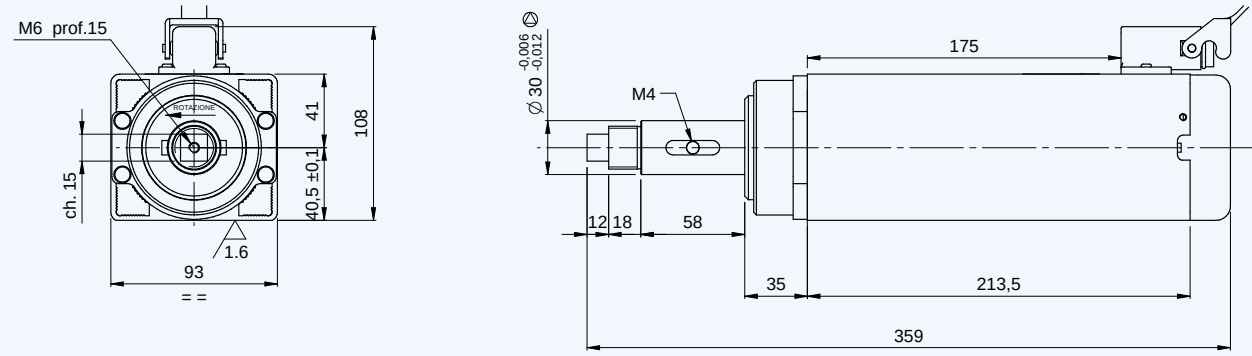

LAYOUT D30 L58 - 1.8 KW

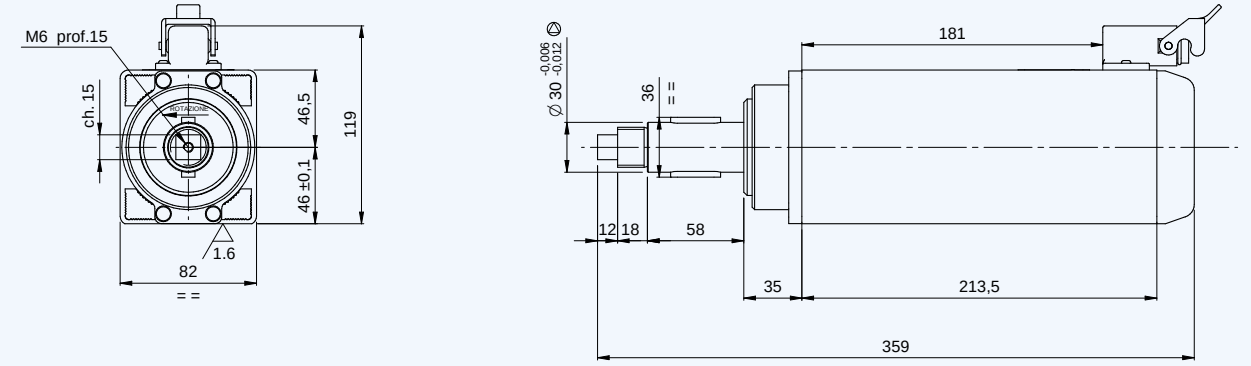

S-11.5/12 12

PRESTAZIONI / PERFORMANCES

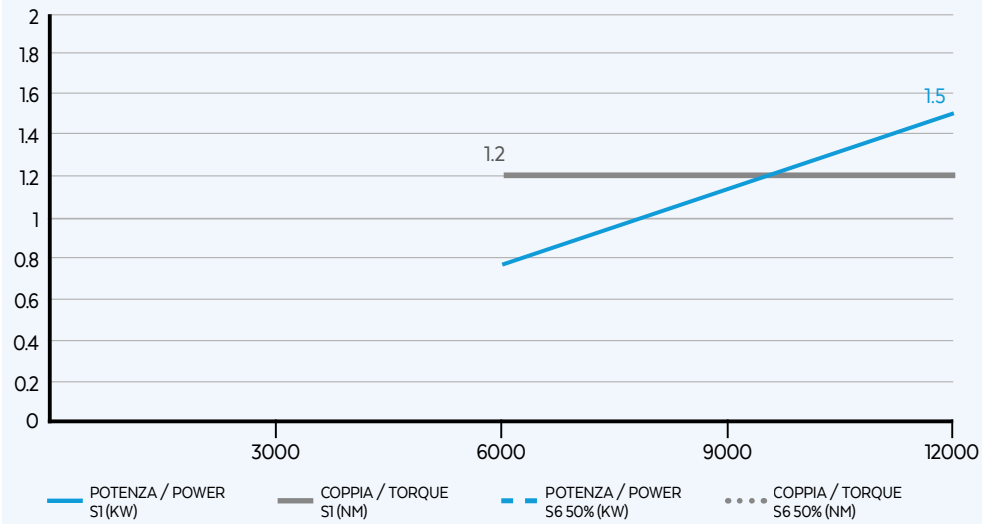

SPECIFICHE TECNICHE / TECHNICAL SPECIFICATIONS

1.5 kW (S1)
1.2 Nm (S1)
12000 rpm
5.7 A (S1)
220 Volt
8 kg
2 (Poles)
inverter (Supply)

EQUIPAGGIAMENTO / EQUIPMENT

Shaft D30
 Steel bearings
 Air fan shaft
 Grease lubrication
 Manual tool changer

S-11.8/12 12

PRESTAZIONI / PERFORMANCES

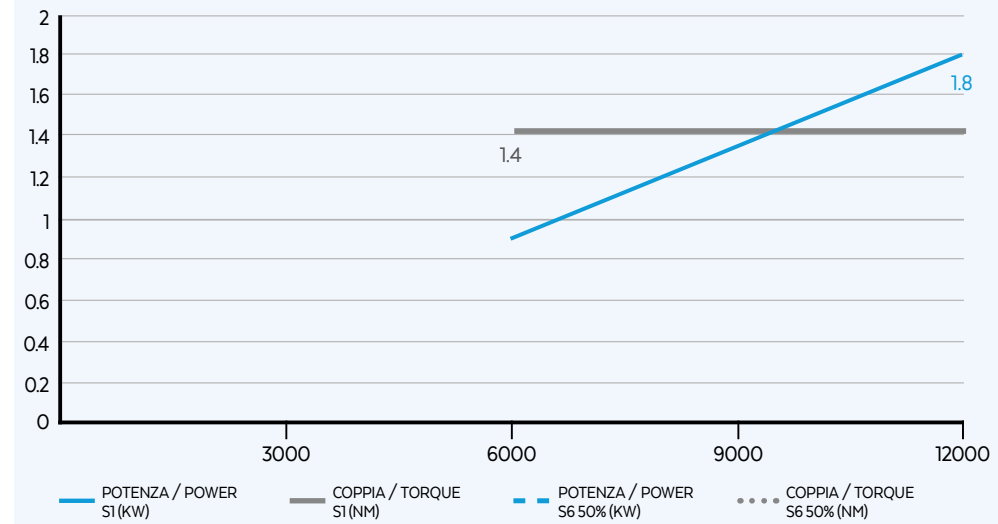

SPECIFICHE TECNICHE / TECHNICAL SPECIFICATIONS

1.8 kW (S1)
1.4 Nm (S1)
12000 rpm
6.5 A (S1)
220 Volt
8 kg
2 (Poles)
inverter (Supply)

EQUIPAGGIAMENTO / EQUIPMENT

Shaft D30
 Steel bearings
 Air fan shaft
 Grease lubrication
 Manual tool changer

MULTITECH QN

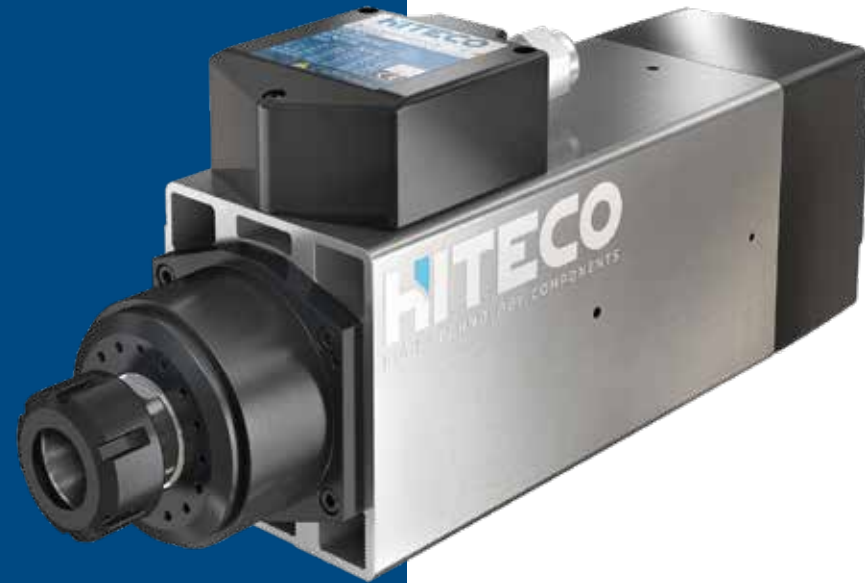

SUITABLE FOR MACHINING WOOD AND ALUMINUM
AVAILABLE WITH ELECTROFAN, COMPRESSED AIR AND SHAFT-POWERED FAN COOLING
AVAILABLE WITH CERAMIC BEARINGS AVAILABLE WITH ER 32 AND HSK 40C

LAYOUT ER 32 DX

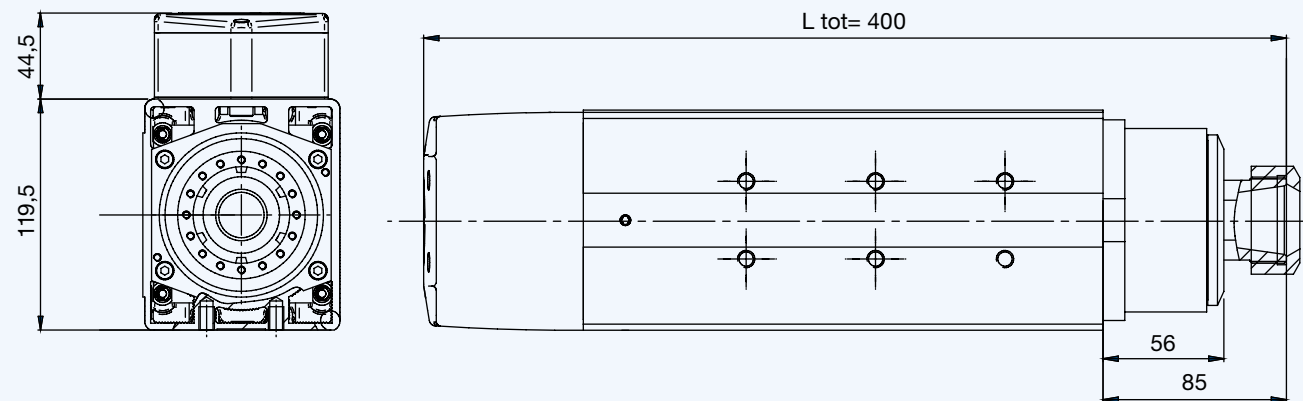

ALTRI LAYOUT / OTHER LAYOUTS

	ΔL	L tot
Aria compressa / Air compressed	-44 mm	356 mm

QN-1F 4.5/18 18

PRESTAZIONI / PERFORMANCES

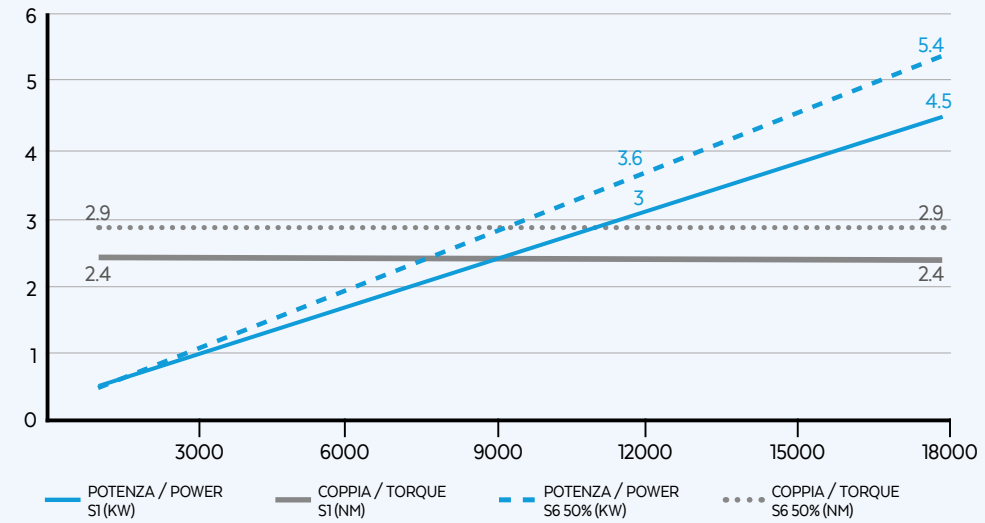

OPZIONALI / OPTIONALS

- HSK 40C
- COM-PRESSED AIR Pressed air cooling

SPECIFICHE TECNICHE / TECHNICAL SPECIFICATIONS

- S1-S6 kW** 4.5/5.4
- S1-S6 A** 9.5/12.8
- Pol es** 2
- S1-S6 Nm** 2.4/2.9
- Volt** 380
- Supply** inverter
- rpm** 18000
- kg** 15
- Dual voltage** 220V-380V

EQUIPAGGIAMENTO / EQUIPMENT

- Steel bearings
- Electrofan cooling
- Manual tool changer
- Grease lubrication
- ER32DX

QN-1F 4.5/18 24

PRESTAZIONI / PERFORMANCES

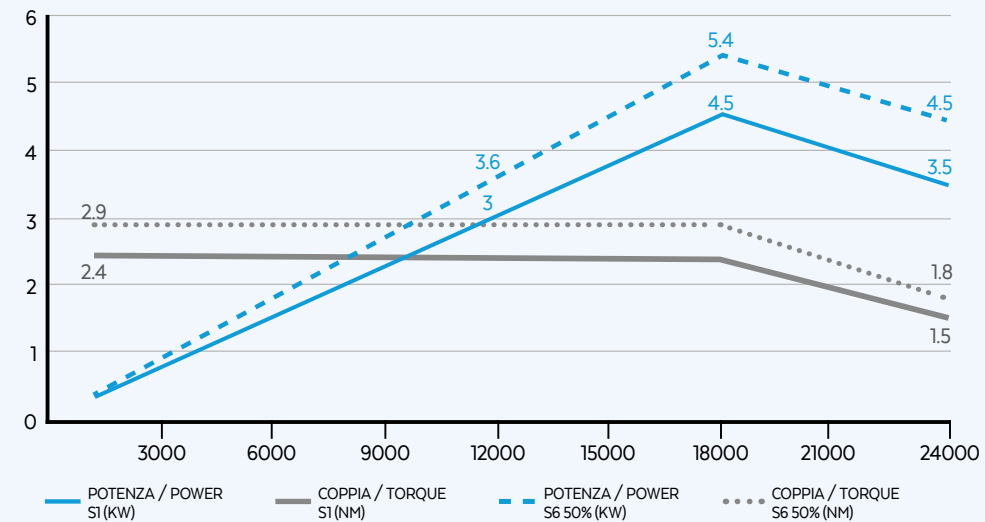

OPZIONALI / OPTIONALS

- HSK 40C
- COM-PRESSED AIR Pressed air cooling

SPECIFICHE TECNICHE / TECHNICAL SPECIFICATIONS

- S1-S6 kW** 4.5/5.4
- S1-S6 A** 9.5/15
- Pol es** 2
- S1-S6 Nm** 2.4/2.9
- Volt** 380
- Supply** inverter
- rpm** 24000
- kg** 15
- Dual voltage** 220V-380V

EQUIPAGGIAMENTO / EQUIPMENT

- Ceramic ball bearings
- Electrofan cooling
- Manual tool changer
- Grease lubrication
- ER32DX

QN-1F 6/18 18

PRESTAZIONI / PERFORMANCES

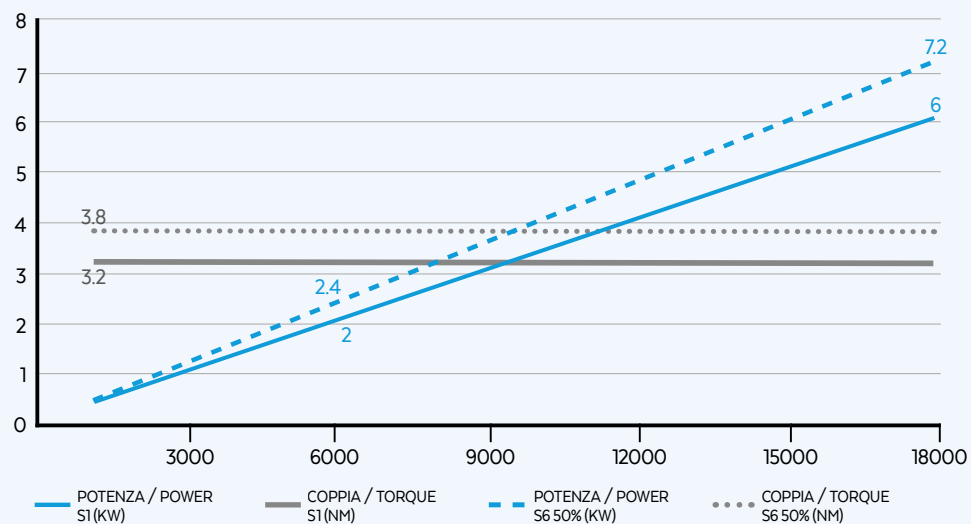

OPZIONALI / OPTIONALS

- COM-PRESSED AIR Pressed air cooling
- HSK 40C

SPECIFICHE TECNICHE / TECHNICAL SPECIFICATIONS

- S1-S6 kW 6/7.2
- S1-S6 A 12.5/15.3
- Pol es 2
- S1-S6 Nm 3.2/3.8
- Volt 380
- Supply inverter
- rpm 18000
- kg 15
- Dual voltage 220V-380V

EQUIPAGGIAMENTO / EQUIPMENT

- Steel bearings
- Electrofan cooling
- Manual tool changer
- Grease lubrication
- ER32DX

QN-1F 6/18 24

PRESTAZIONI / PERFORMANCES

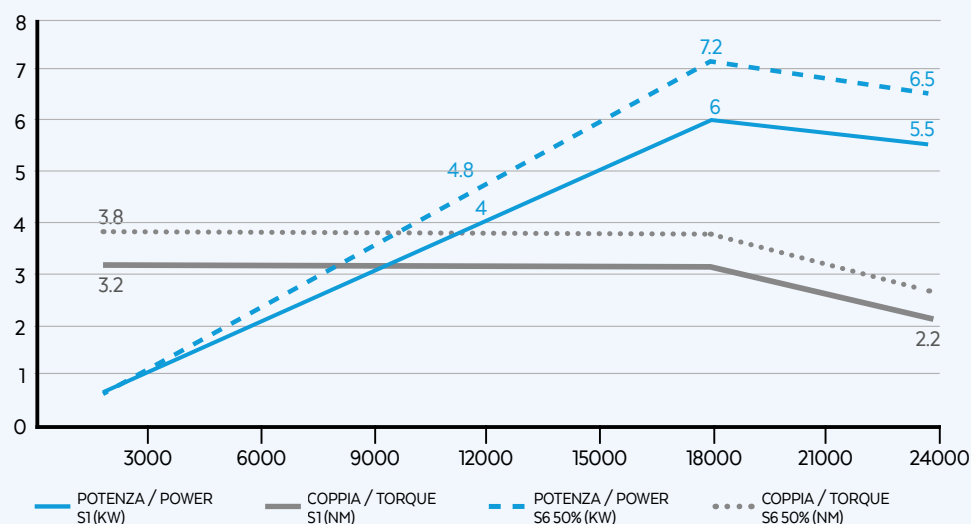

OPZIONALI / OPTIONALS

- COM-PRESSED AIR Pressed air cooling
- HSK 40C

SPECIFICHE TECNICHE / TECHNICAL SPECIFICATIONS

- S1-S6 kW 6/7.2
- S1-S6 A 12.5/15.3
- Pol es 2
- S1-S6 Nm 3.2/3.8
- Volt 380
- Supply inverter
- rpm 24000
- kg 15
- Dual voltage 220V-380V

EQUIPAGGIAMENTO / EQUIPMENT

- Ceramic ball bearings
- Electrofan cooling
- Manual tool changer
- Grease lubrication
- ER32DX

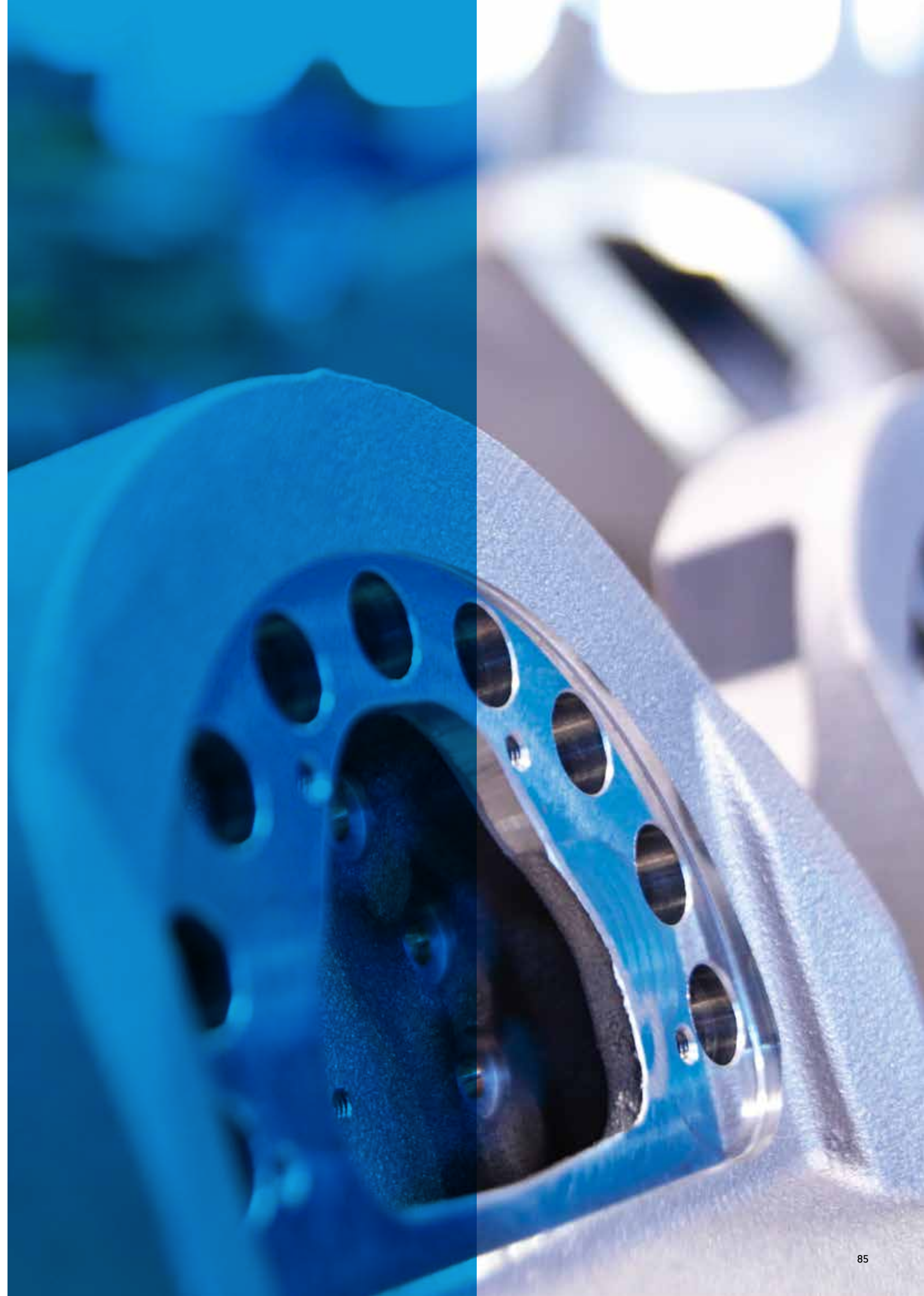

MULTITECH MQH

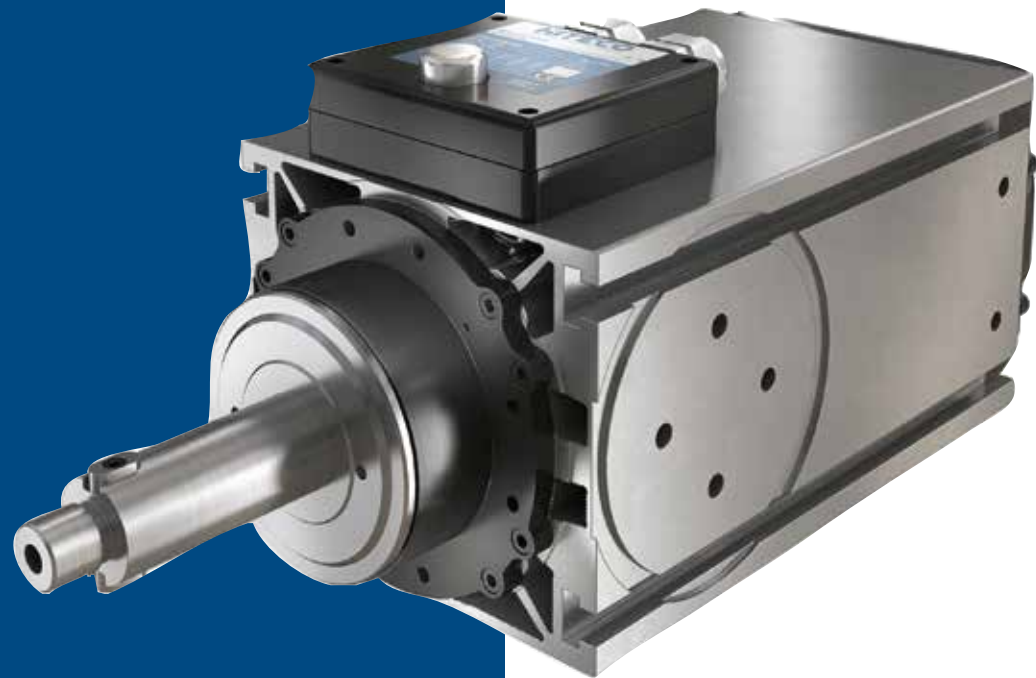

SUITABLE FOR MACHINING WOOD
POWER UP TO 13 KW
SHAFT ROTATION SENSOR

LAYOUT D40

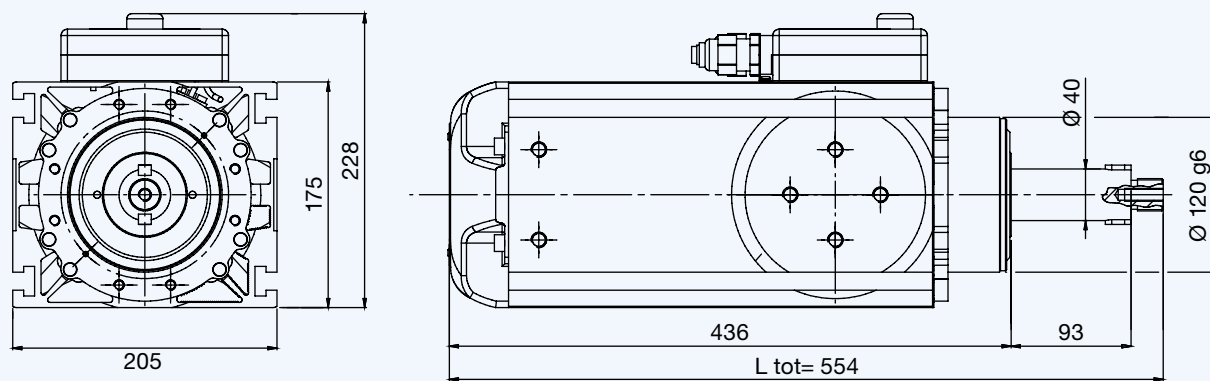

MQH-113/6 9

PRESTAZIONI / PERFORMANCES

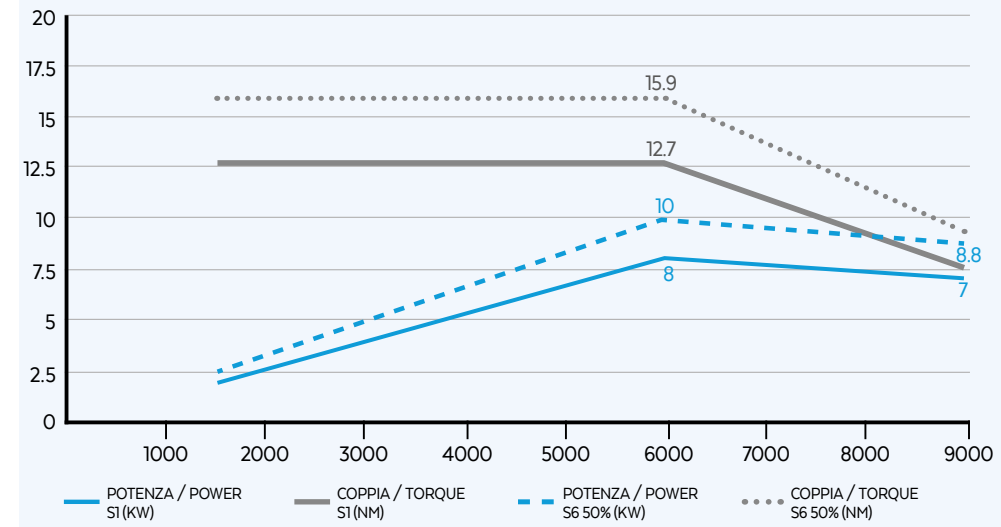

SPECIFICHE TECNICHE / TECHNICAL SPECIFICATIONS

S1-S6 kW 8/10	S1-S6 A 15.8/18.7	Pol es 4
S1-S6 Nm 12.7/15.9	Volt 380	Sup ply inverter
rpm 9000	kg 55	

EQUIPAGGIAMENTO / EQUIPMENT

Shaft D40	Air fan shaft	Manual tool changer	Sensors s3
Steel bearings	Grease lubrication		

MQH-113/6 9

PRESTAZIONI / PERFORMANCES

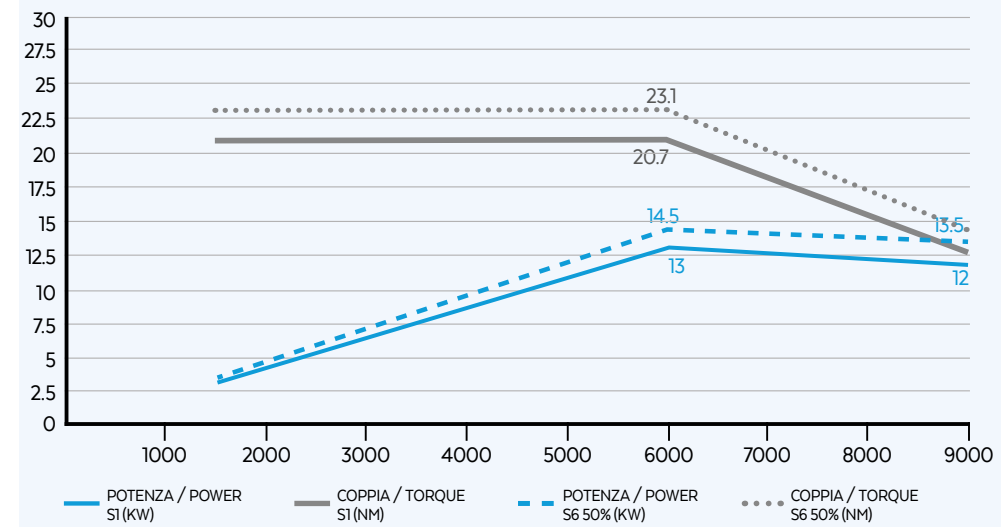

SPECIFICHE TECNICHE / TECHNICAL SPECIFICATIONS

S1-S6 kW 13/14.5	S1-S6 A 25.8/30	Pol es 4
S1-S6 Nm 20.7/22.7	Volt 380	Sup ply inverter
rpm 9000	kg 55	

EQUIPAGGIAMENTO / EQUIPMENT

Shaft D40	Air fan shaft	Manual tool changer	Sensors s3
Steel bearings	Grease lubrication		

C-AXIS FOR POWERTECH 300-400



Compass Naso corto (NC) con 3 utenze pneumatiche, con servomotore Yaskawa
Compass Short Nose (NC) with 3 pneumatic connections With Yaskawa servo-motor

Compass Naso lungo (NL) con 3 utenze pneumatiche, con servomotore Yaskawa
Compass Long Nose (NL) with 3 pneumatic connections With Yaskawa servo-motor

OPZIONALI / OPTIONALS

Disponibile senza servomotore
Available without servomotor

CONO PORTA UTENSILE TOOL HOLDER



Tool holder
Cono porta utensile HSK63F ER 32 M40X1.5_DX

Tool holder
Cono porta utensile ISO30 ER 32 M40X1.5_DX

Per altre tipologie di pinze porta utensile, contatta lo staff Hiteco
For other tool holder types, please contact Hiteco staff

PINZA PORTA UTENSILE TOOL FINGER



Tool finger
Pinza porta utensile HSK 63F

Tool finger
Pinza porta utensile ISO 30

Per altre tipologie di pinze porta utensile, contatta lo staff Hiteco
For other tool finger sizes, please contact Hiteco staff

RIFERIMENTO TESTINE ANTI-ROTATION SLEEVES



Riferimento testine per PT200: 2 posizioni, senza utenze pneumatiche
Anti-rotation sleeve for PT 200: 2 positions Without pneumatic connections

Riferimento testine per PT250: 2 posizioni, con o senza utenze pneumatiche
Anti-rotation sleeves for PT 250: 2 positions With or without pneumatic connections

Riferimento testine per PT300-400: 2 posizioni, disponibile in versione Naso corto e Naso lungo (NC e NL), con e senza utenze pneumatiche
Anti-rotation sleeves for PT 300-400: 2 positions Available with Short and Long Nose (NC and NL) With or without pneumatic connections

Riferimento testine per mandrini 5 assi (con 1 utenza pneumatica)
Anti-rotation sleeves for 5-axis spindles With 1 pneumatic connection

SCAMBIATORE DI CALORE HEAT EXCHANGER

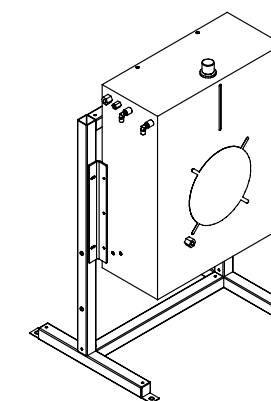

Potenza di raffreddamento
Cooling power 5000 W with liquid temperature +40°, air temperature +20°C

Portata liquido
Liquid flow 4 lt/min at 5,5 bar

Capacità serbatoio
Tank capacity 5 lt

OPZIONALI / OPTIONALS

Disponibile versione senza supporto e tubi flessibili
Available without support and flexible hoses



ITM UNITEC GmbH
Kuchengrund 19
71522 Backnang

Tel. +49 7191 495 265-0
Fax +49 7191 495 265 10
info@itm-unitec.com
www.itm-unitec.com

