

TESTE DI FORATURA
BORING UNITS



Componenti ad **alta tecnologia** per produttori di macchine utensili.

--
High-tech components for machine tool manufacturers.

Hiteco è specializzata nella progettazione e realizzazione di componenti elettromeccanici industriali ad alta tecnologia per le macchine utensili.

Elettromandriani A.T.C., elettromandriani M.T.C., teste birotative, teste di foratura ed aggregati.

--
Hiteco is specialized in design and manufacture of high technology industrial electromechanical components for machine tools. **A.T.C. electrospindles, M.T.C. electrospindles, birotary heads, boring units and aggregates.**



Hiteco si propone sul mercato internazionale con un'ampia gamma di prodotti per la lavorazione di: **legno, plastica, materiali avanzati, vetro, pietra e metallo.**

--
Hiteco offers a wide range of products on international market for **wood, plastic, advanced materials, glass, stone and metal processing.**



Hiteco nasce nel 1977 come divisione interna di **SCM Group**, azienda leader mondiale nella costruzione di macchine utensili per la lavorazione di una vasta gamma di materiali, realizzando un percorso di crescita esponenziale. Diventa nel 2008 **un'unità di profitto per servire il mercato terzi**. Oggi realizza prodotti di riferimento nel mercato dei componenti, diventando uno tra i più importanti player mondiali nel settore.

--
Hiteco founded in 1977 as an internal division of the **SCM Group**, leading company in machine tools construction for processing a wide range of materials, had an increasingly exponential growth. In 2008 it become **a profit unit for external customers**. Today Hiteco offers key products for the components market, becoming one of the most important world players in the sector.



Una **presenza capillare** per un **servizio best-in-class e worldwide.**

--
A capillary presence for a **best-in-class** and **worldwide service.**

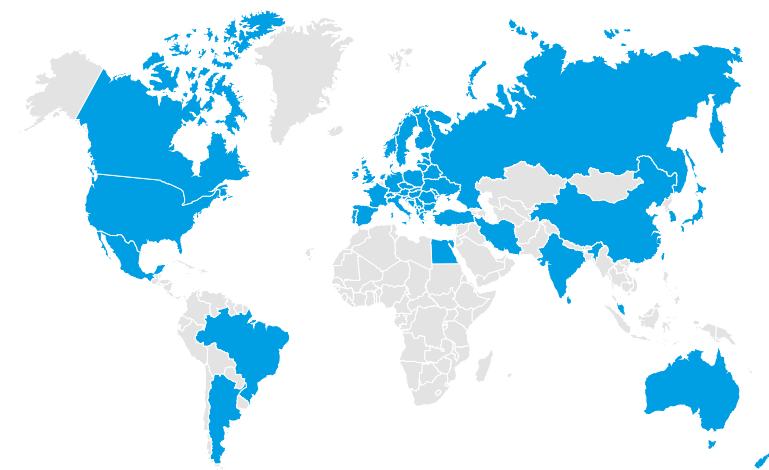

La distribuzione capillare dell'azienda risponde alla volontà di Hiteco di essere vicina al cliente con la presenza sul territorio di **tecnici specializzati** che sono garanzia di una risposta estremamente rapida e professionale: non solo per ridurre fermi macchina e problemi alla produzione, ma anche per creare valore aggiunto con la proposta di soluzioni efficaci ed innovative. Questa attenzione, oltre ai ridotti tempi di consegna, è uno dei motivi che ha portato Hiteco ad avere la più alta **customer satisfaction** nel mercato internazionale.

--
The widespread distribution of the company responds to the desire of Hiteco to be close to the customer with the presence of **specialized technicians** on the territory who guarantee an extremely rapid and professional response: not only to reduce machine downtimes and production problems, but also to create added value with the proposal of effective and innovative solutions. Such care, in addition to reduced delivery times, is one of the reason that led Hiteco to have the highest **customer satisfaction** on the international market.



INDICE INDEX

Dati tecnici e illustrazioni non sono vincolanti e, per il costante sviluppo di prodotti e servizi, HITECO si riserva il diritto di effettuare modifiche senza preavviso.

Technical data and illustrations are not binding and, for the constant development of products and services, HITECO reserves the right to make modifications without prior notice.



WOOD

p.7 SERIE **TF.A**

- p. 7 TF.A.5V.0H.0B.A
- p. 8 TF.A.7V.0H.0B.A
- p. 9 TF.A.9V.0H.0B.A

p.10 SERIE **TF.B**

- p. 10 TF.B.7V.4H.2B.A
- p. 11 TF.B.8V.3H.0B.A
- p. 12 TF.B.9V.3H.1B.A
- p. 13 TF.B.12V.0H.0B.A

p.14 SERIE **TF.C**

- p. 14 TF.C.12V.4H.2B.A
- p. 15 TF.C.12V.6H.0B.A
- p. 16 TF.C.14V.3H.1B.A
- p. 17 TF.C.16V.0H.2B.A

p.18 SERIE **TF.D**

- p. 18 TF.D.9V.3H.1B.A

p.19 SERIE **TF.E**

- p. 19 TF.E.11V.4H.0B.A

p.20 SERIE **TF.F**

- p. 20 TF.F.10V.3H.1B.A

p.21 SERIE **TF.H**

- p. 21 TF.H.9V.0H.0B.A

p.22 SERIE **TF.L**

- p. 22 TF.L.14V.4H.0B.A

CONFIGURA LA TUA FORATRICE
CONFIGURE YOUR BORING UNITS

IDENTIFICAZIONE TESTE DI FORATURE / BORING HEAD IDENTIFICATION KEY

Example: TF.A.5V.OH.1B.A

TF TESTA DI FORATURA / BORING HEAD

A DEFINISCI TIPO CORPO / DEFINE CASE TYPE

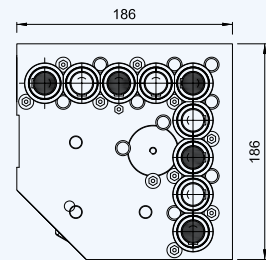

CORPO / CASE A = 186 x 186

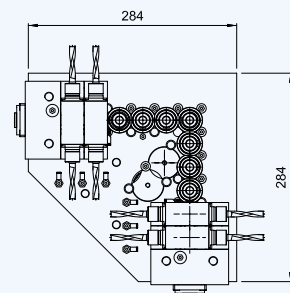

CORPO / CASE B = 284 x 284

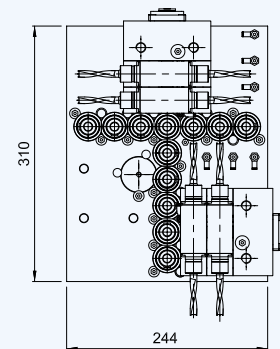

CORPO / CASE C = 244 x 310

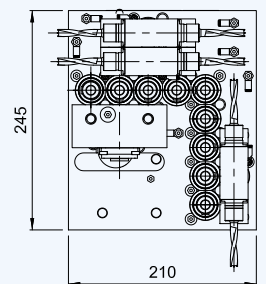

CORPO / CASE D = 210 x 245

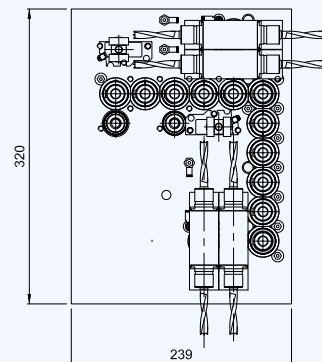

CORPO / CASE E = 239 x 320

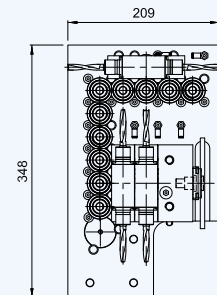

CORPO / CASE F = 209 x 348

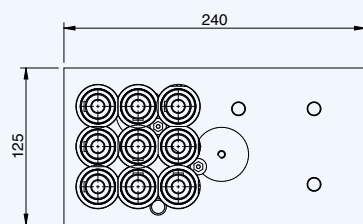

CORPO / CASE H = 240 x 125

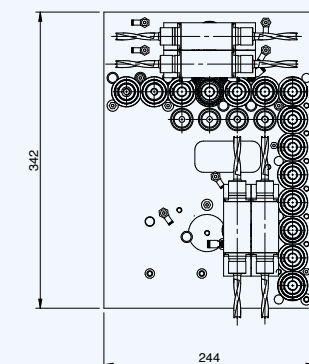

CORPO / CASE L = 244 x 342

5V DEFINISCI N° DI MANDRINI VERTICALI / DEFINE Nr. VERTICAL SPINDLES

OH DEFINISCI N° DI MANDRINI ORIZZONTALI / DEFINE Nr. HORIZONTAL SPINDLES

1B DEFINISCI N° DI GRUPPI LAMA / DEFINE Nr. OF BLADE KIT

A CONFIGURAZIONE / CONFIGURATION

TF.A.5V.OH.0B.A

SPECIFICHE TECNICHE / TECHNICAL SPECIFICATIONS

Attacco punta / Tool connection	10 H7 mm
Interasse punta / Distance between centers	32 mm
Max lunghezza punta / Max boring bits length	70 mm
Corsa mandrini verticali / Vertical spindles stroke	60 mm
Potenza motore / Motor power	1,5 kW
Max rotazione verticali / Max vertical spindles stroke	8.000 RPM
Peso / Weight	25 kg

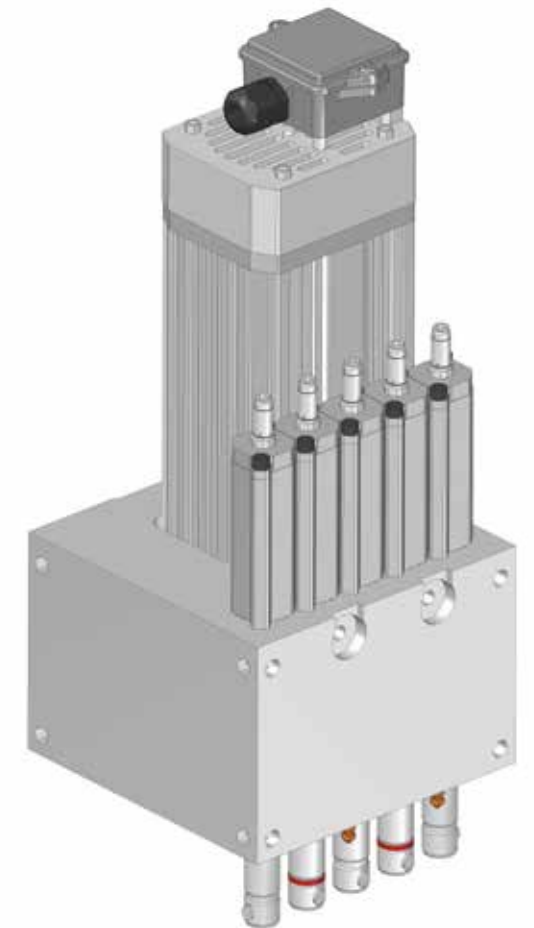

LAYOUT

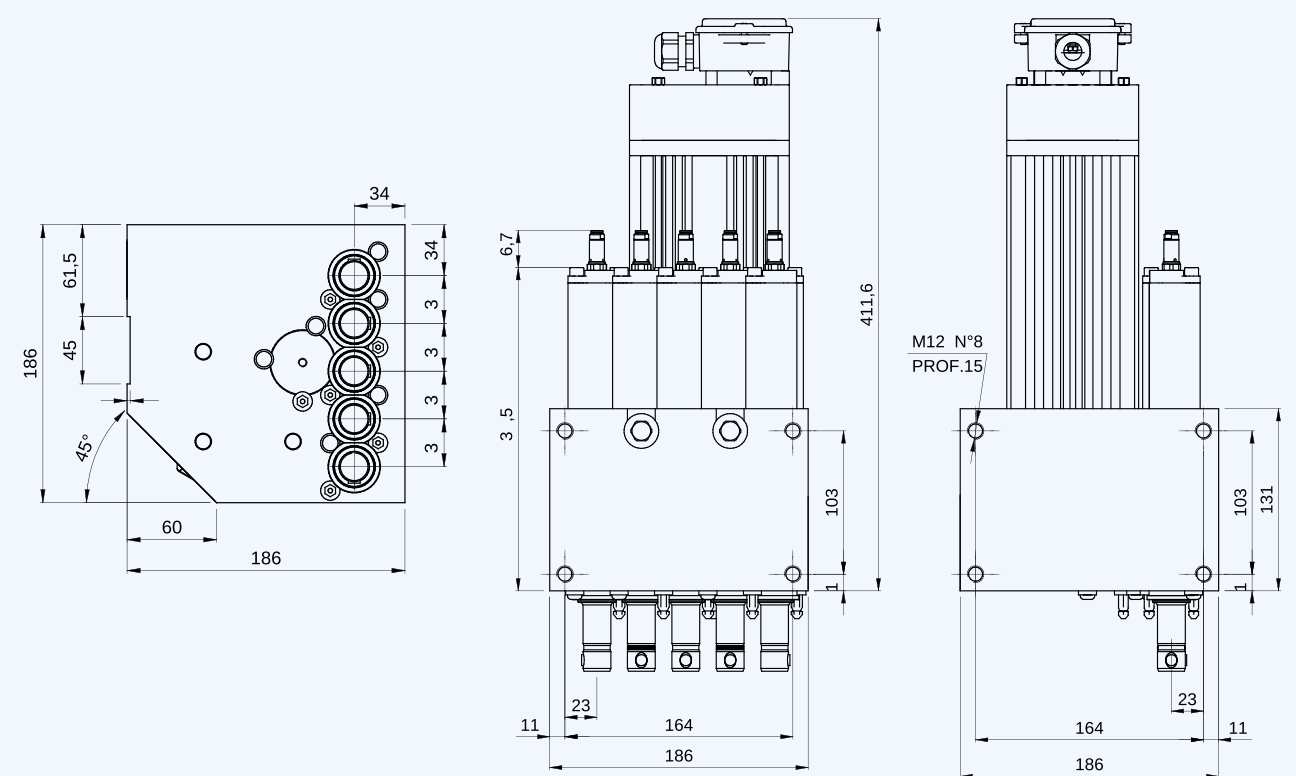

TF.A.7V.0H.0B.A

SPECIFICHE TECNICHE TECHNICAL SPECIFICATIONS

Attacco punte Tool connection	10 H7 mm
Interasse punte Distance between centers	32 mm
Max lunghezza punte Max boring bits lenght	70 mm
Corsa mandrini verticali Vertical spindles stroke	60 mm
Potenza motore Motor power	1,5 kW
Max rotazione verticali Max vertical spindles speed	8.000 RPM
Peso Weight	24 kg

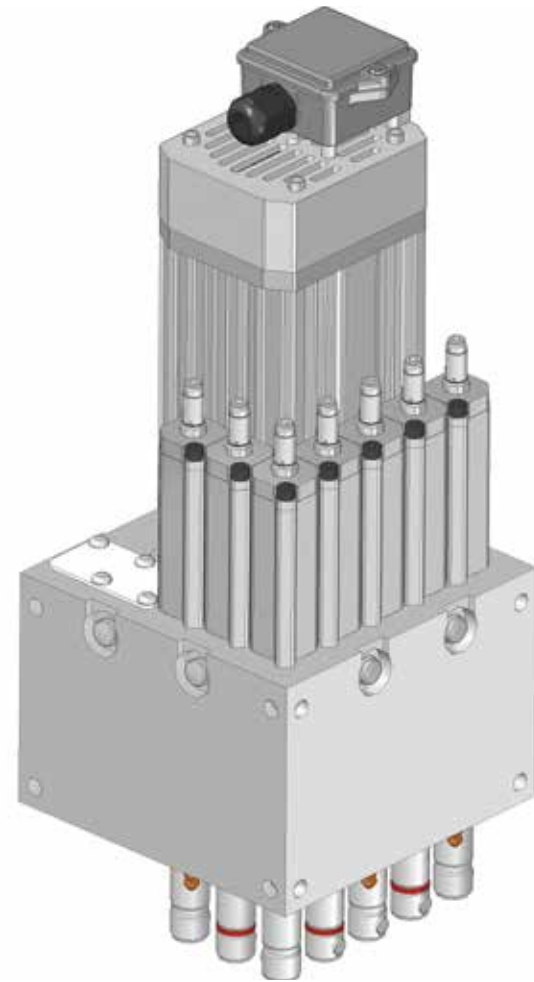

TF.A.9V.0H.0B.A

SPECIFICHE TECNICHE TECHNICAL SPECIFICATIONS

Attacco punte Tool connection	10 H7 mm
Interasse punte Distance between centers	32 mm
Max lunghezza punte Max boring bits lenght	70 mm
Corsa mandrini verticali Vertical spindles stroke	60 mm
Potenza motore Motor power	1,5 kW
Max rotazione verticali Max vertical spindles speed	8.000 RPM
Peso Weight	25 kg

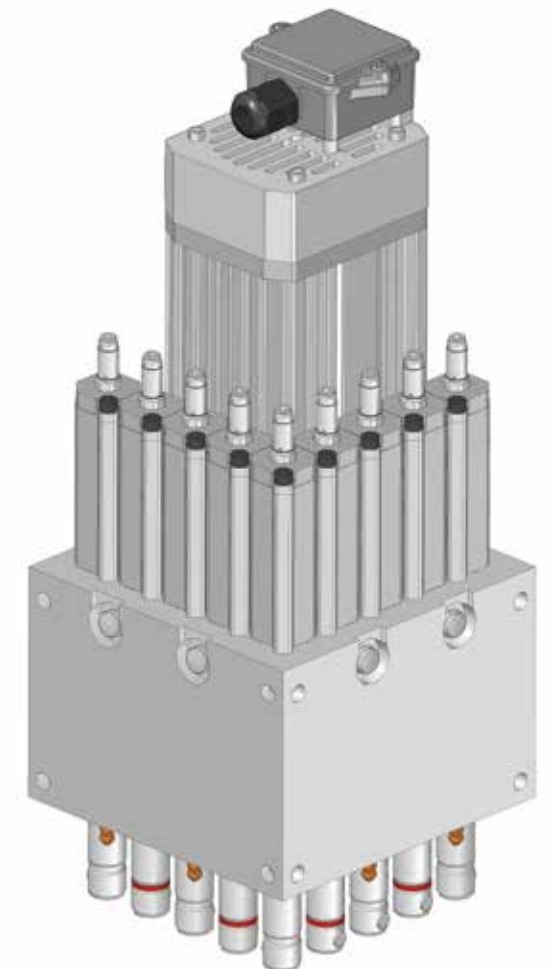

LAYOUT

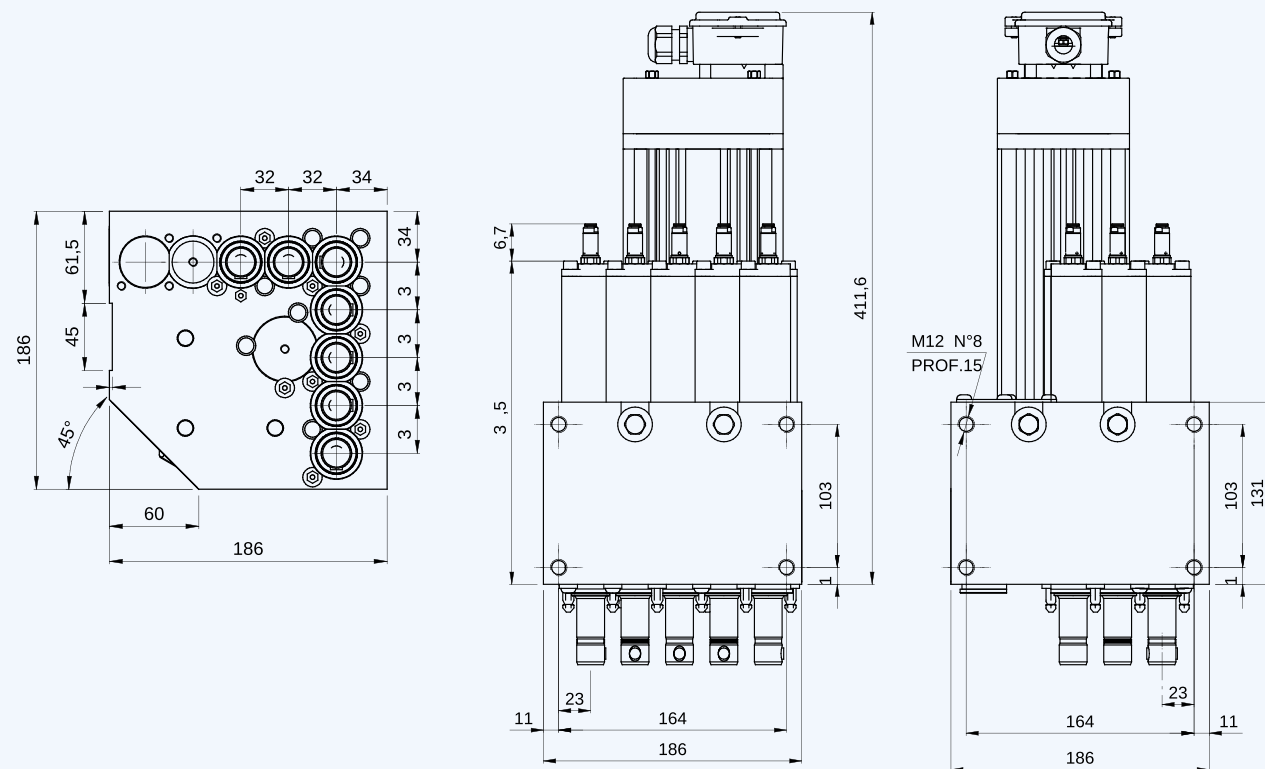

LAYOUT

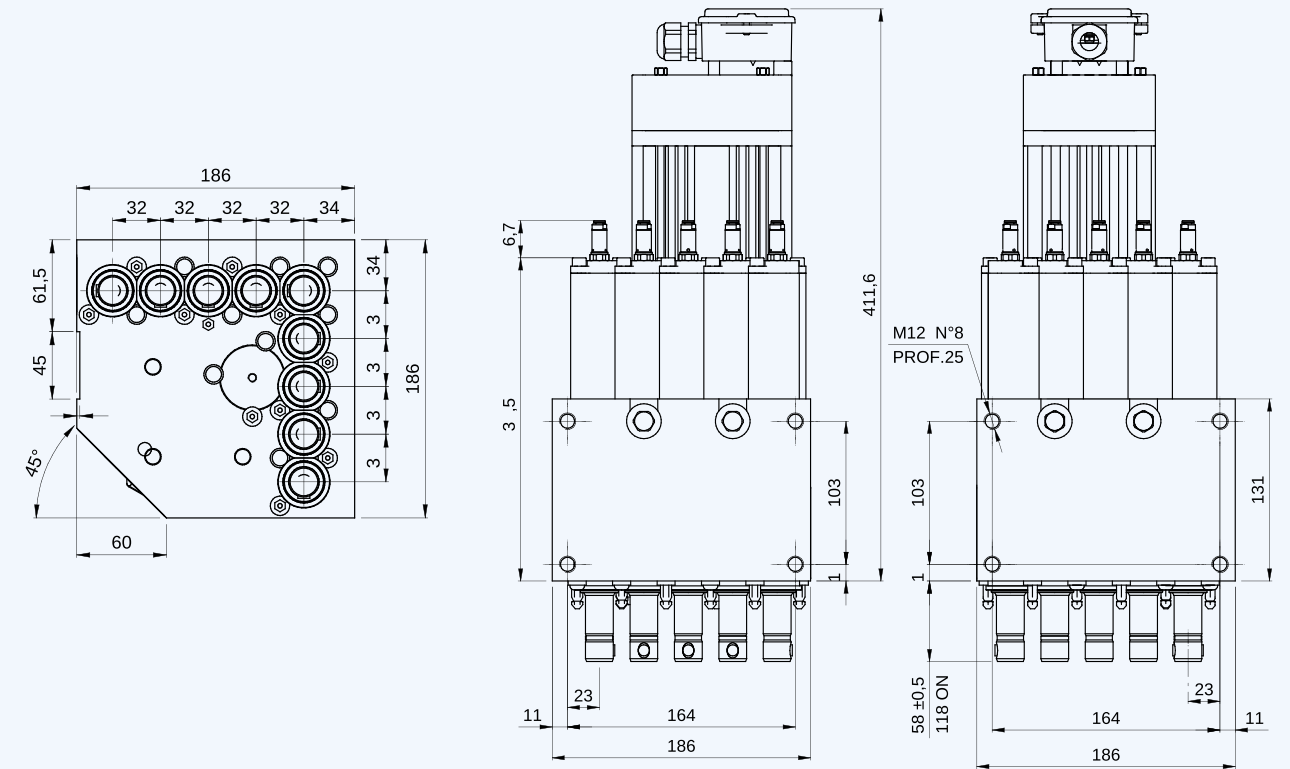

TF.B.7V.4H.2B.A

SPECIFICHE TECNICHE TECHNICAL SPECIFICATIONS

Attacco punte Tool connection	10 H7 mm
Interasse punte Distance between centers	32 mm
Max lunghezza punte Max boring bits length	70 mm
Corsa mandrini verticali Vertical spindles stroke	60 mm
Corsa mandrini orizzontali Horizontal spindles stroke	75 mm
Corsa gruppo lama Blade stroke	60 mm
Potenza motore Motor power	1,7 kW
Max rotazione verticali Max vertical spindles speed	8.000 RPM
Max rotazione orizzontali Max horizontal spindles speed	8.000 RPM
Max rotazione lama Max blade speed	10.000 RPM
Peso Weight	60 kg

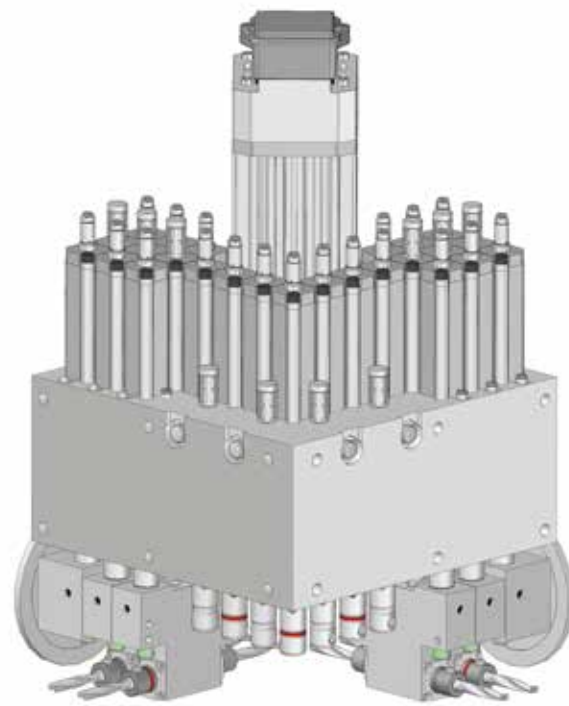

TF.B.8V.3H.0B.A

SPECIFICHE TECNICHE TECHNICAL SPECIFICATIONS

Attacco punte Tool connection	10 H7 mm
Interasse punte Distance between centers	32 mm
Max lunghezza punte Max boring bits length	70 mm
Corsa mandrini verticali Vertical spindles stroke	60 mm
Corsa mandrini orizzontali Horizontal spindles stroke	75 mm
Potenza motore Motor power	1,5 kW
Max rotazione verticali Max vertical spindles speed	8.000 RPM
Max rotazione orizzontali Max horizontal spindles speed	8.000 RPM
Peso Weight	50 kg

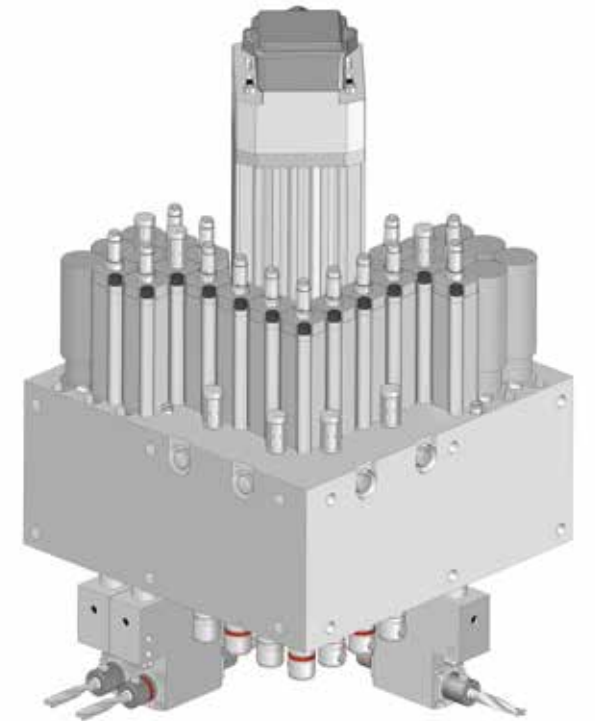

LAYOUT

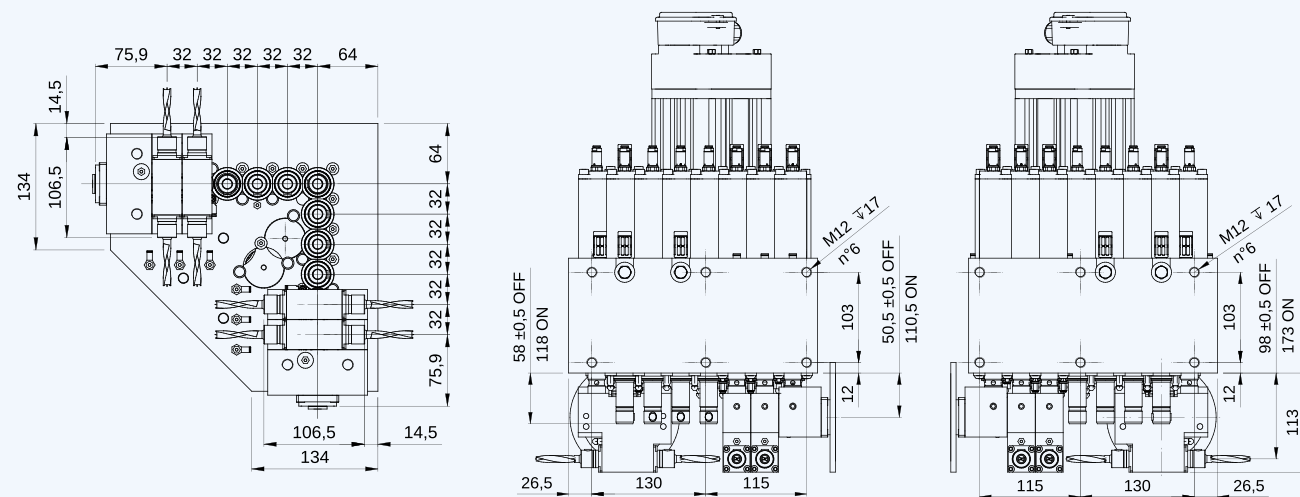

LAYOUT

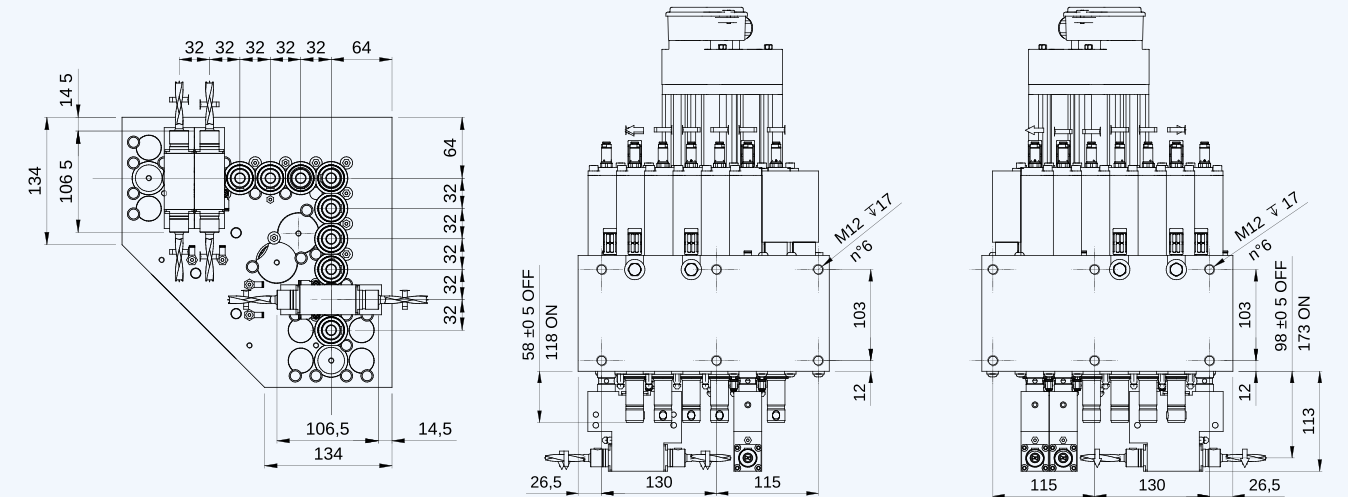

TF.B.9V.3H.1B.A

SPECIFICHE TECNICHE TECHNICAL SPECIFICATIONS

Attacco punte Tool connection	10 H7 mm
Interasse punte Distance between centers	32 mm
Max lunghezza punte Max boring bits lenght	70 mm vertical
Corsa mandrini verticali Vertical spindles stroke	60 mm single effect cylinder
Corsa mandrini orizzontali Horizontal spindles stroke	75 mm double effect cylinders
Corsa gruppo lama BDE stroke	60 mm double effect cylinders
Potenza motore Motor power	1,7 kW
Max rotazione verticali Max vertical spindles speed	8.000 RPM
Max rotazione orizzontali Max horizontal spindles speed	8.000 RPM
Max rotazione lama Max blade speed	10.000 RPM
Peso Weight	60 kg

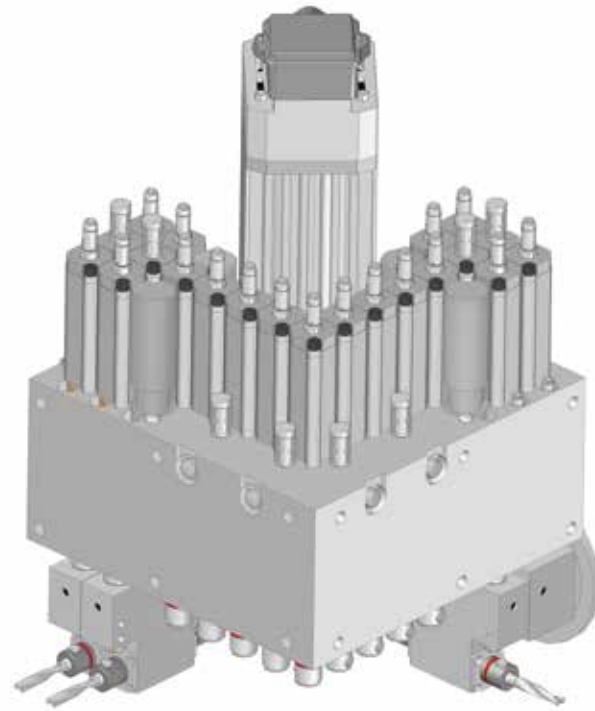

TF.B.12V.0H.0B.A

SPECIFICHE TECNICHE TECHNICAL SPECIFICATIONS

Attacco punte Tool connection	10 H7 mm
Interasse punte Distance between centers	32 mm
Max lunghezza punte Max boring bits lenght	70 mm vertical
Corsa mandrini verticali Vertical spindles stroke	60 mm single effect cylinder
Potenza motore Motor power	1,7 kW
Max rotazione verticali Max vertical spindles speed	8.000 RPM
Peso Weight	55 kg

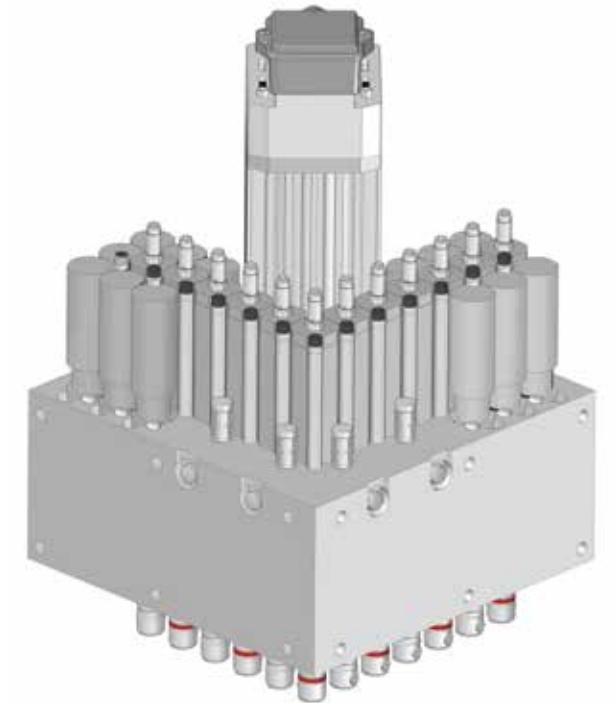

LAYOUT

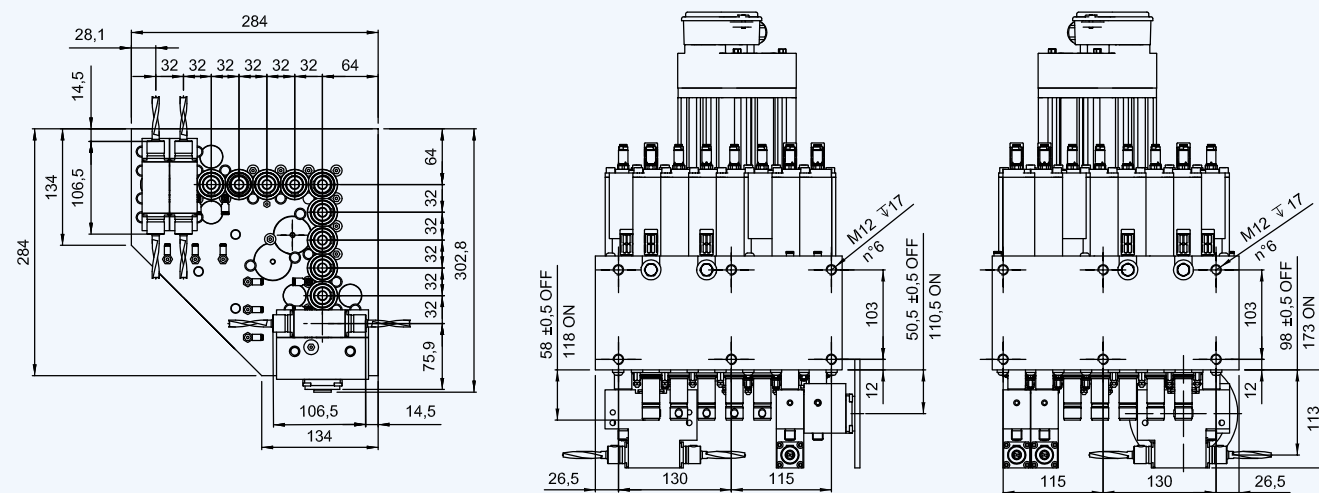

LAYOUT

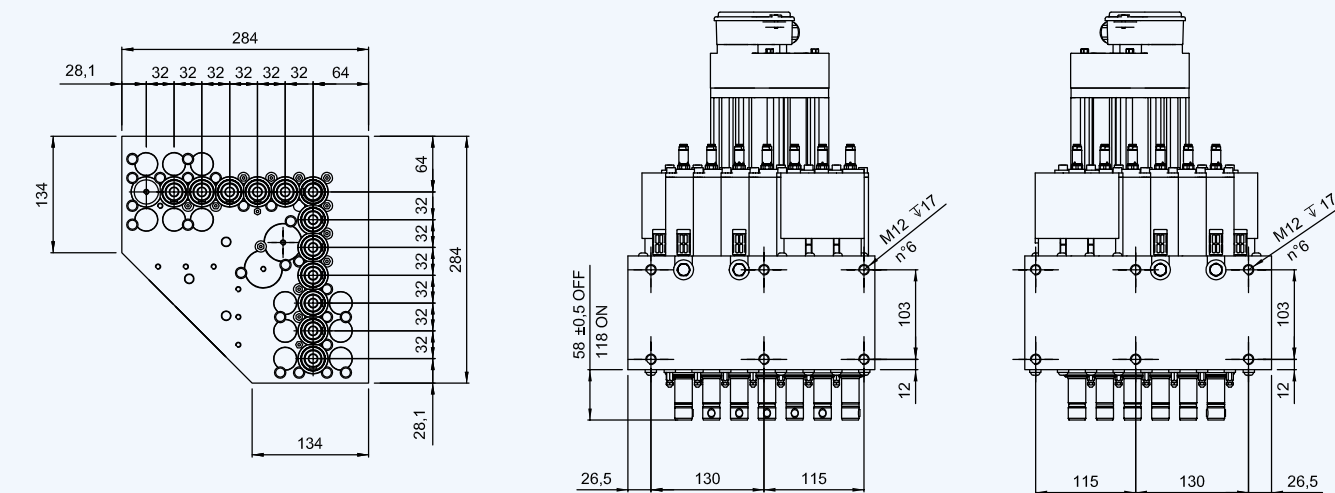

TF.C.12V.4H.2B.A

SPECIFICHE TECNICHE TECHNICAL SPECIFICATIONS

Attacco punta Tool connection	10 H7 mm
Interasse punta Distance between centers	32 mm
Max lunghezza punta Max boring bits lenght	70 mm
Corsa mandrini verticali Vertical spindles stroke	60 mm
Corsa mandrini orizzontali Horizontal spindles stroke	75 mm
Corsa gruppo lama Blade stroke	60 mm
Potenza motore Motor power	1,7 kW
Max rotazione verticali Max vertical spindles speed	8.000 RPM
Max rotazione orizzontali Max horizontal spindles speed	8.000 RPM
Max rotazione lama Max blade speed	10.000 RPM
Peso Weight	60 kg

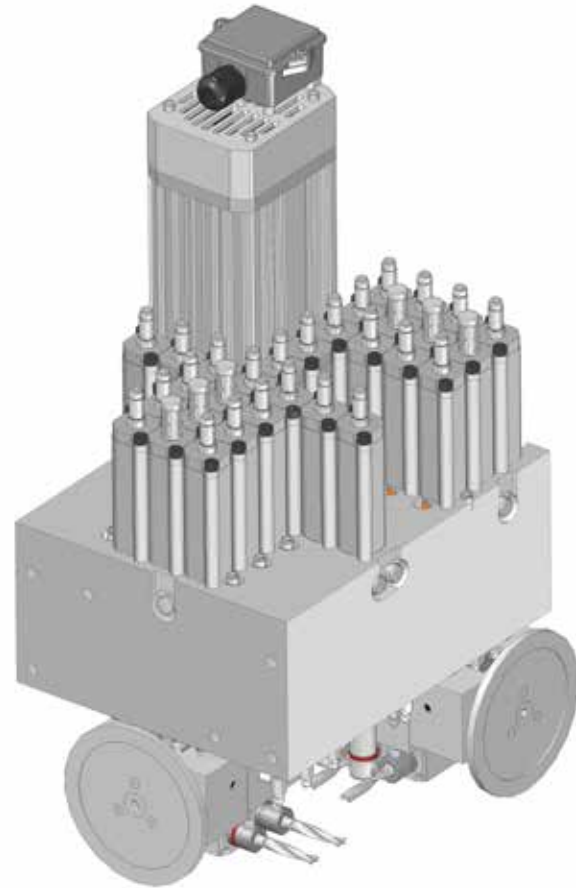

TF.C.12V.6H.0B.A

SPECIFICHE TECNICHE TECHNICAL SPECIFICATIONS

Attacco punta Tool connection	10 H7 mm
Interasse punta Distance between centers	32 mm
Max lunghezza punta Max boring bits lenght	70 mm
Corsa mandrini verticali Vertical spindles stroke	60 mm
Corsa mandrini orizzontali Horizontal spindles stroke	75 mm
Potenza motore Motor power	1,7 kW
Max rotazione verticali Max vertical spindles speed	8.000 RPM
Max rotazione orizzontali Max horizontal spindles speed	8.000 RPM
Peso Weight	60 kg

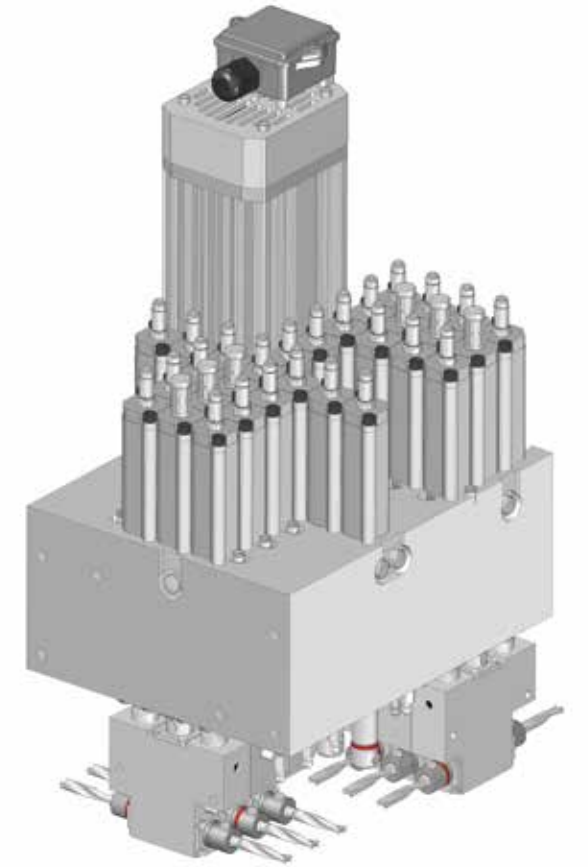

LAYOUT

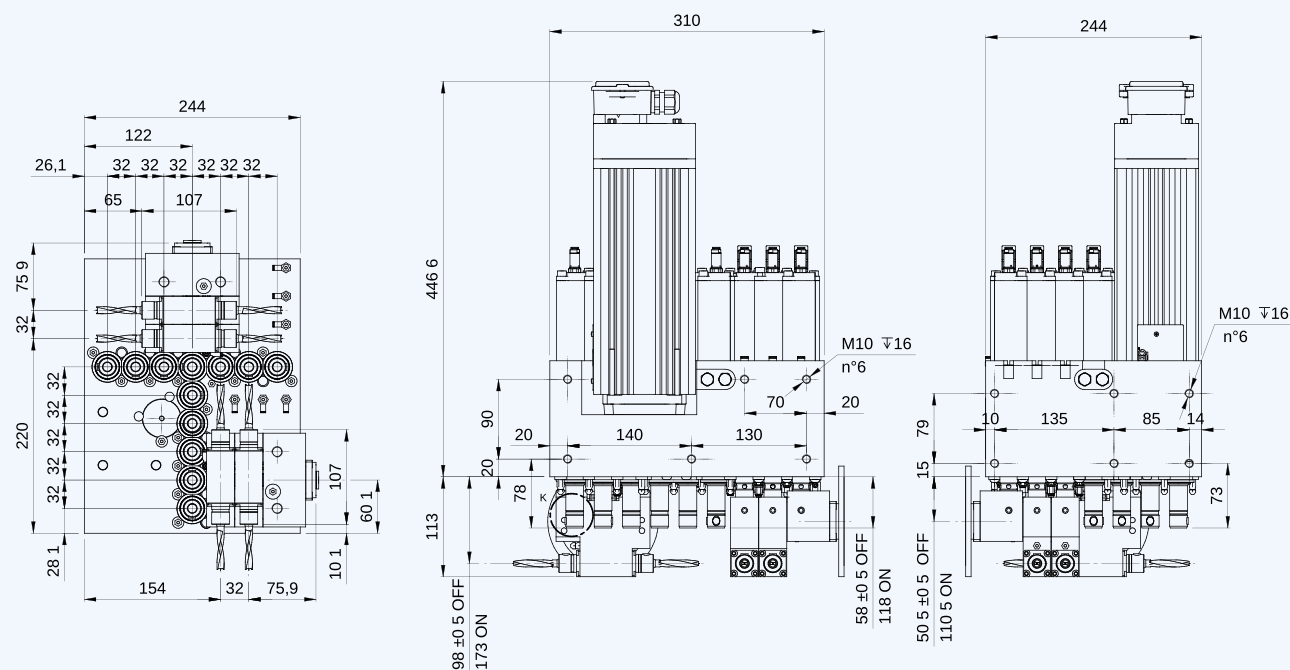

LAYOUT

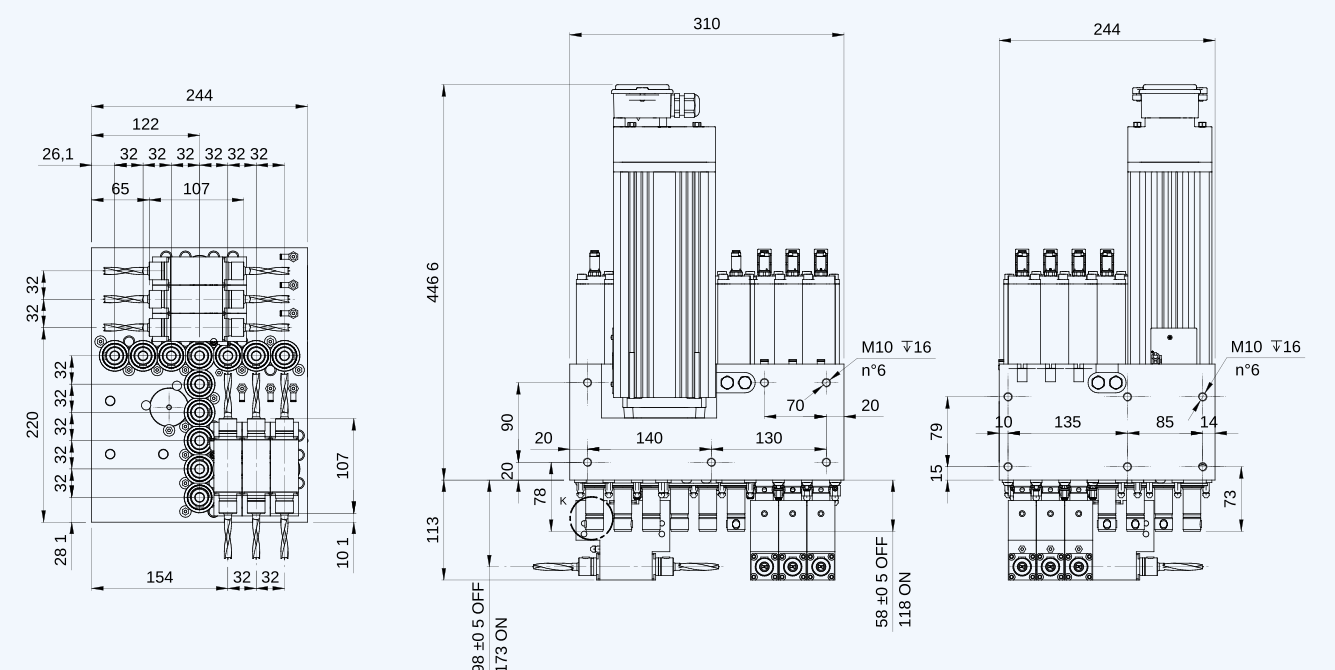

TF.C.14V.3H.1B.A

SPECIFICHE TECNICHE TECHNICAL SPECIFICATIONS

Attacco punte Tool connection	10 H7 mm
Interasse punte Distance between centers	32 mm
Max lunghezza punte Max boring bits lenght	70 mm
Corsa mandrini verticali Vertical spindles stroke	60 mm
Corsa mandrini orizzontali Horizontal spindles stroke	75 mm
Corsa gruppo lama Blade stroke	60 mm
Potenza motore Motor power	1,7 kW
Max rotazione verticali Max vertical spindles speed	8.000 RPM
Max rotazione orizzontali Max horizontal spindles speed	8.000 RPM
Max rotazione lama Max blade speed	10.000 RPM
Peso Weight	50 kg

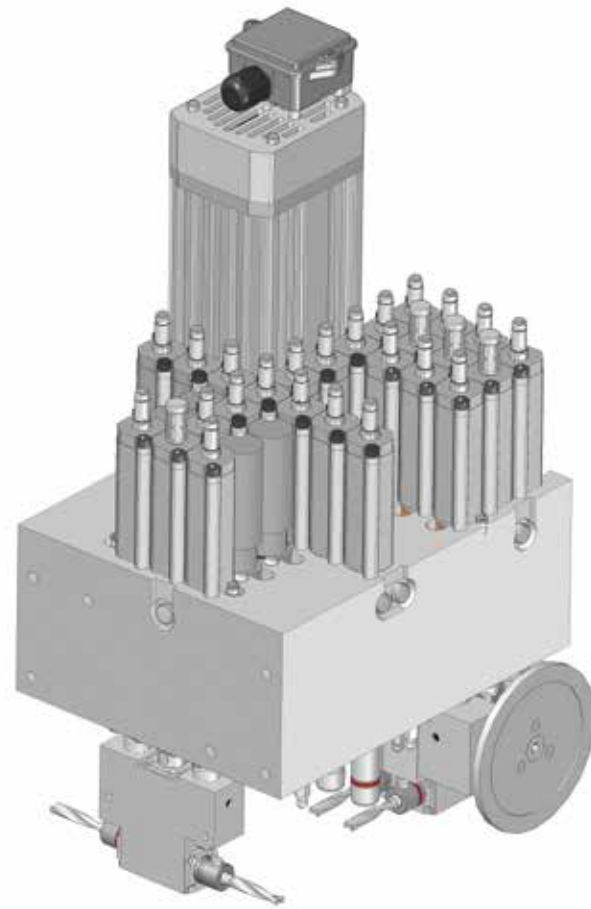

TF.C.16V.0H.2B.A

SPECIFICHE TECNICHE TECHNICAL SPECIFICATIONS

Attacco punte Tool connection	10 H7 mm
Interasse punte Distance between centers	32 mm
Max lunghezza punte Max boring bits lenght	70 mm vertical
Corsa mandrini verticali Vertical spindles stroke	60 mm single effect cylinder
Corsa gruppo gama BDE stroke	60 mm double effect cylinders
Potenza motore Motor power	1,7 kW
Max rotazione verticali Max vertical spindles speed	8.000 RPM
Max rotazione orizzontali Max horizontal spindles speed	8.000 RPM
Max rotazione lama Max blade speed	10.000 RPM
Peso Weight	60 kg

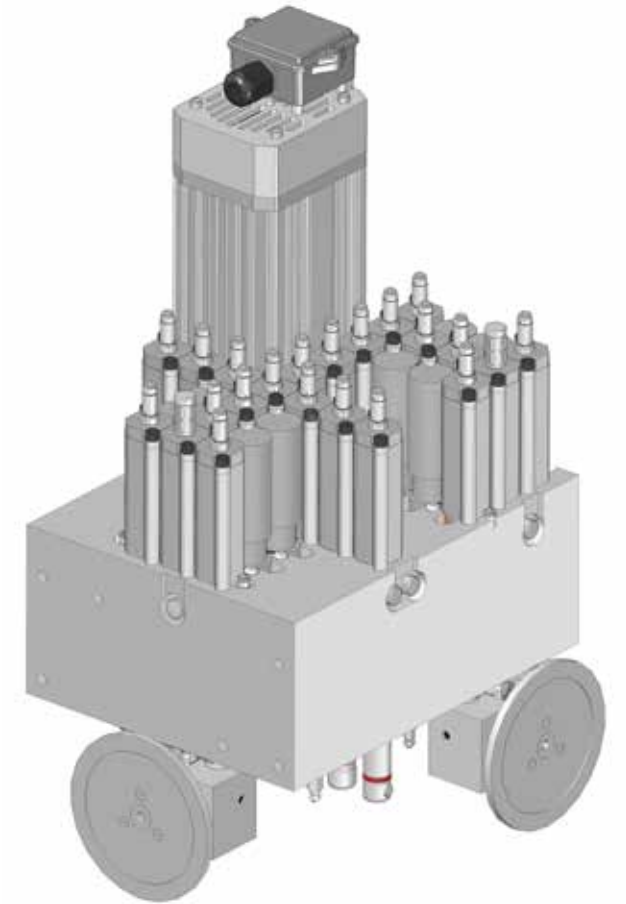

LAYOUT

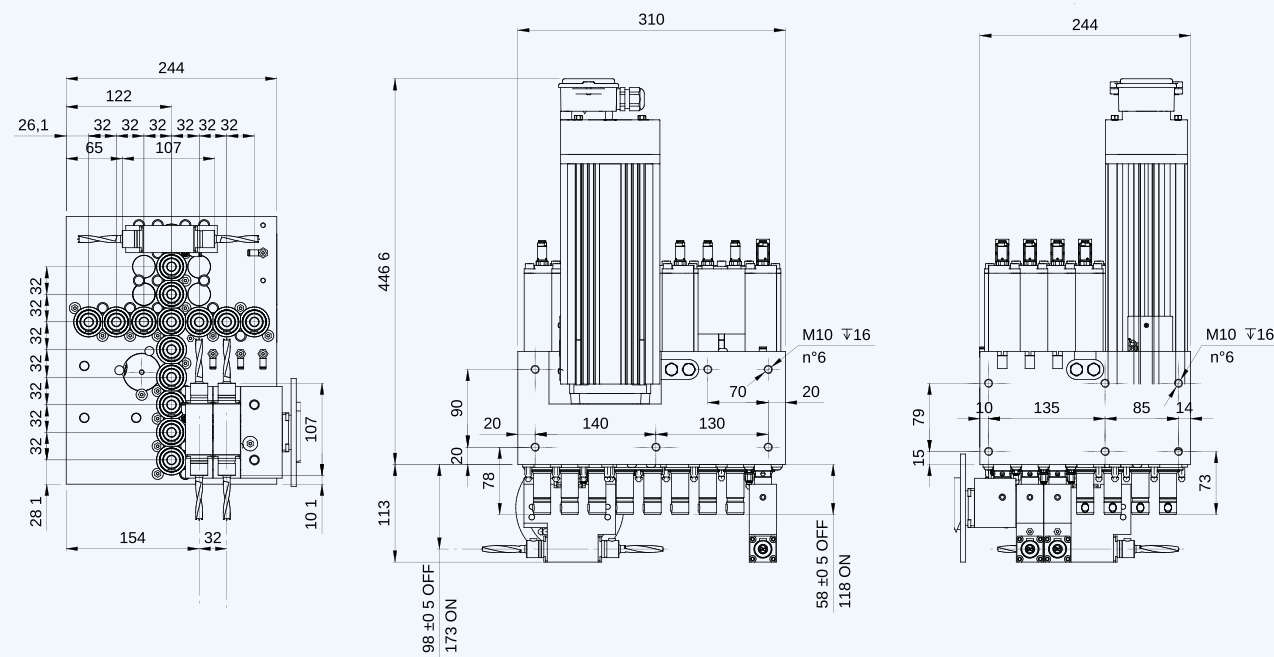

LAYOUT

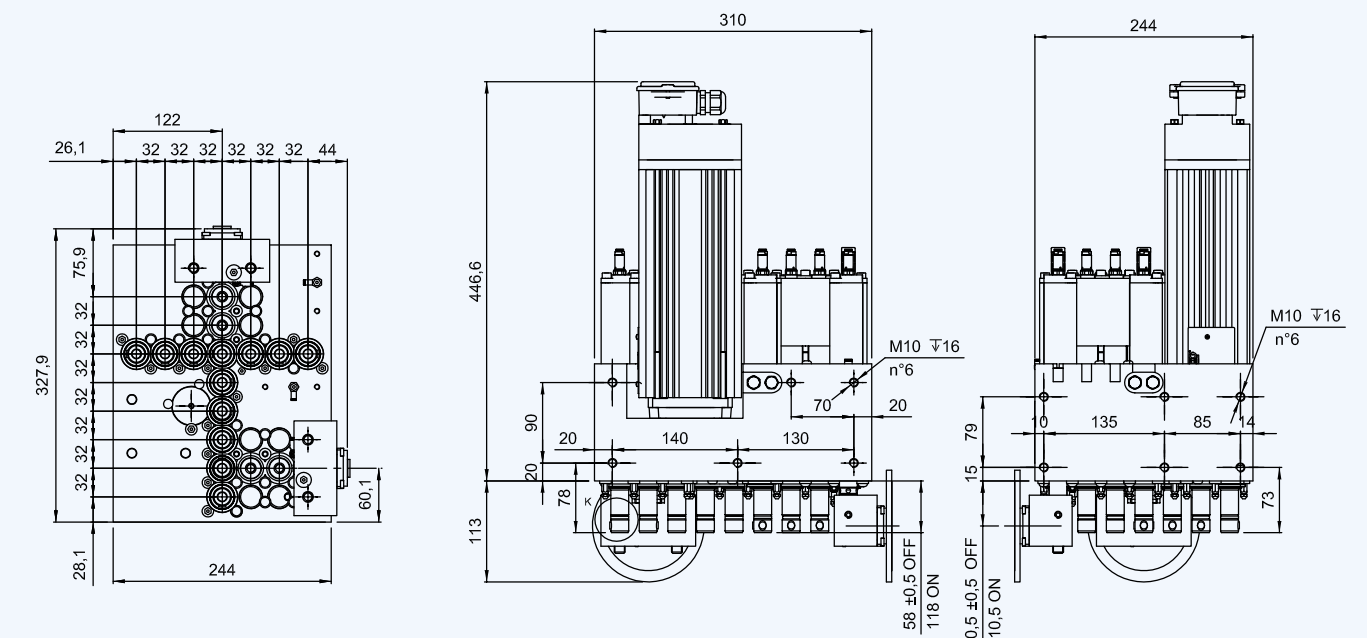

TF.D.9V.3H.1B.A

SPECIFICHE TECNICHE TECHNICAL SPECIFICATIONS

Attacco punte Tool connection	10 H7 mm
Interasse punte Distance between centers	32 mm
Max lunghezza punte Max boring bits lenght	70 mm
Corsa mandrini verticali Vertical spindles stroke	60 mm
Corsa mandrini orizzontali Horizontal spindles stroke	75 mm
Corsa gruppo lama Blade stroke	60 mm
Potenza motore Motor power	1,7 kW
Max rotazione verticali Max vertical spindles speed	8.000 RPM
Max rotazione orizzontali Max horizontal spindles speed	8.000 RPM
Max rotazione lama Max blade speed	10.000 RPM
Peso Weight	50 kg

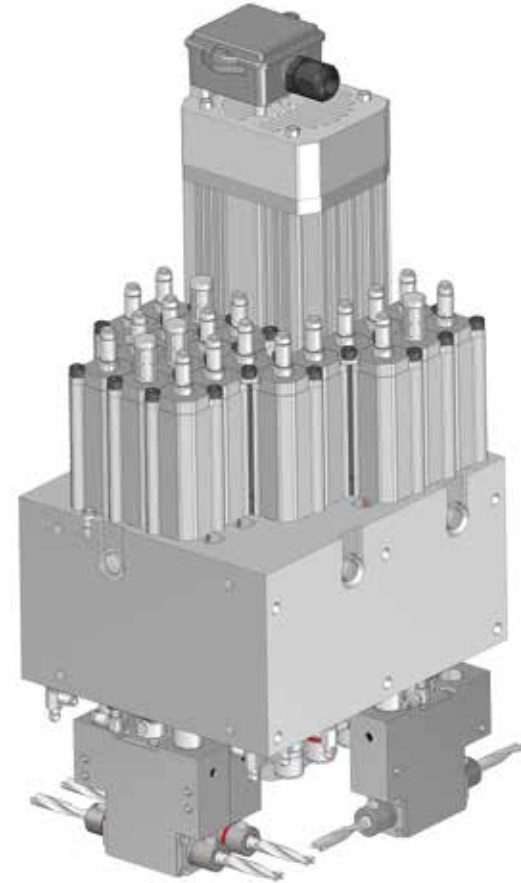

TF.E.11V.4H.0B.A

SPECIFICHE TECNICHE TECHNICAL SPECIFICATIONS

Attacco punte Tool connection	10 H7 mm
Interasse punte Distance between centers	32 mm
Max lunghezza punte Max boring bits lenght	70 mm vertical
Corsa mandrini verticali Vertical spindles stroke	60 mm single effect cylinder
Corsa mandrini orizzontali Horizontal spindles stroke	75 mm double effect cylinders
Potenza motore Motor power	1,7 kW
Max rotazione verticali Max vertical spindles speed	8.000 RPM
Max rotazione orizzontali Max horizontal spindles speed	8.000 RPM
Peso Weight	65 kg

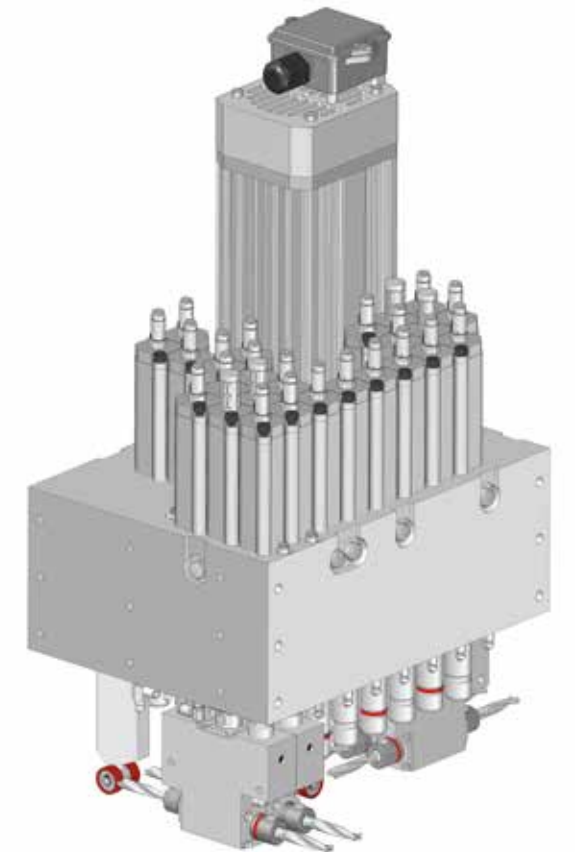

LAYOUT

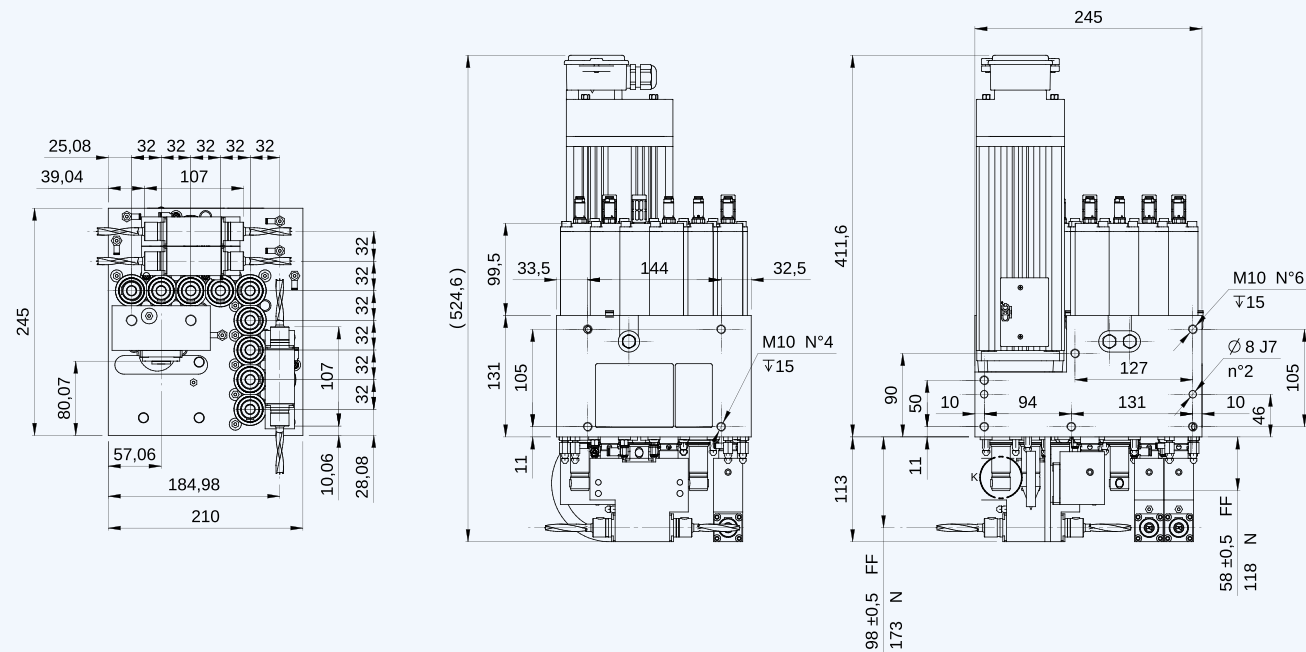

LAYOUT

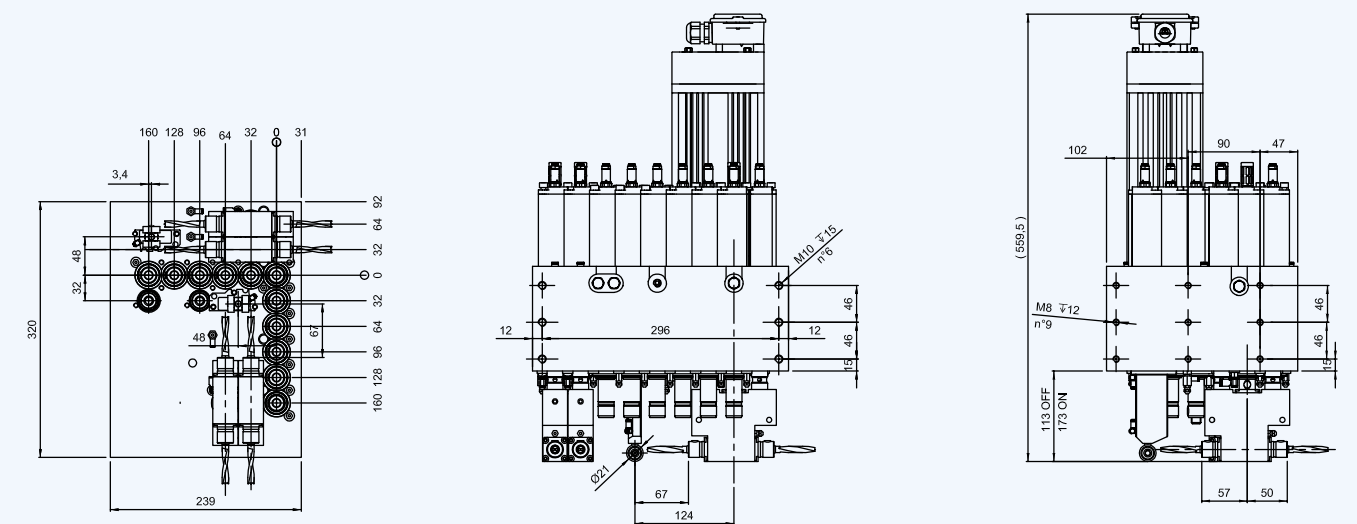

TF.F.10V.3H.1B.A

SPECIFICHE TECNICHE TECHNICAL SPECIFICATIONS

Attacco punta Tool connection	10 H7 mm
Interasse punte Distance between centers	32 mm
Max lunghezza punta Max boring bits lenght	70 mm
Corsa mandrini verticali Vertical spindles stroke	60 mm
Corsa mandrini orizzontali Horizontal spindles stroke	75 mm
Corsa gruppo lama Blade stroke	60 mm
Potenza motore Motor power	1,7 kW
Max rotazione verticali Max vertical spindles speed	8.000 RPM
Max rotazione orizzontali Max horizontal spindles speed	8.000 RPM
Max rotazione lama Max blade speed	10.000 RPM
Peso Weight	50 kg

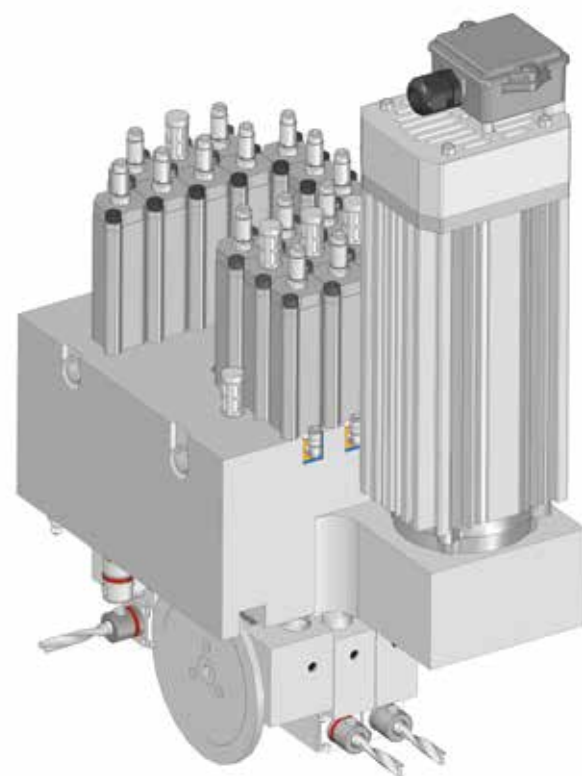

TF.H.9V.0H.0B.A

SPECIFICHE TECNICHE TECHNICAL SPECIFICATIONS

Attacco punta Tool connection	10 H7 mm
Interasse punte Distance between centers	32 mm
Max lunghezza punta Max boring bits lenght	70 mm
Corsa mandrini verticali Vertical spindles stroke	60 mm
Potenza motore Motor power	1,5 kW
Max rotazione verticali Max vertical spindles speed	8.000 RPM
Peso Weight	30 kg

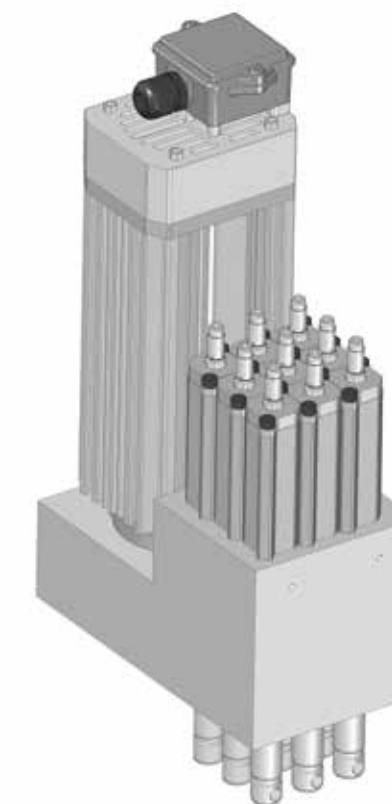

LAYOUT

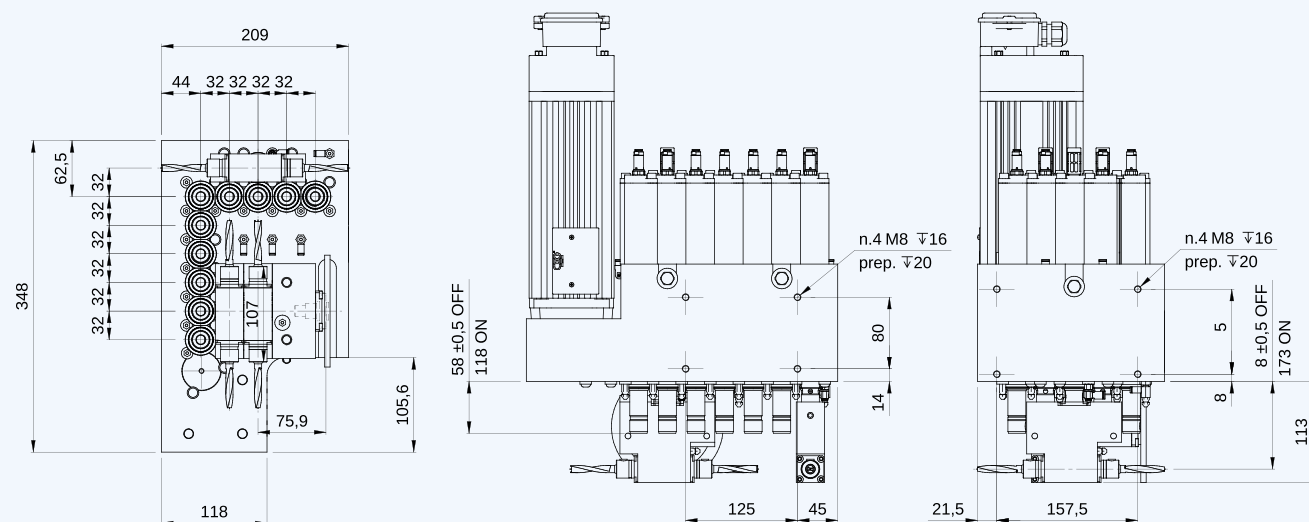

LAYOUT

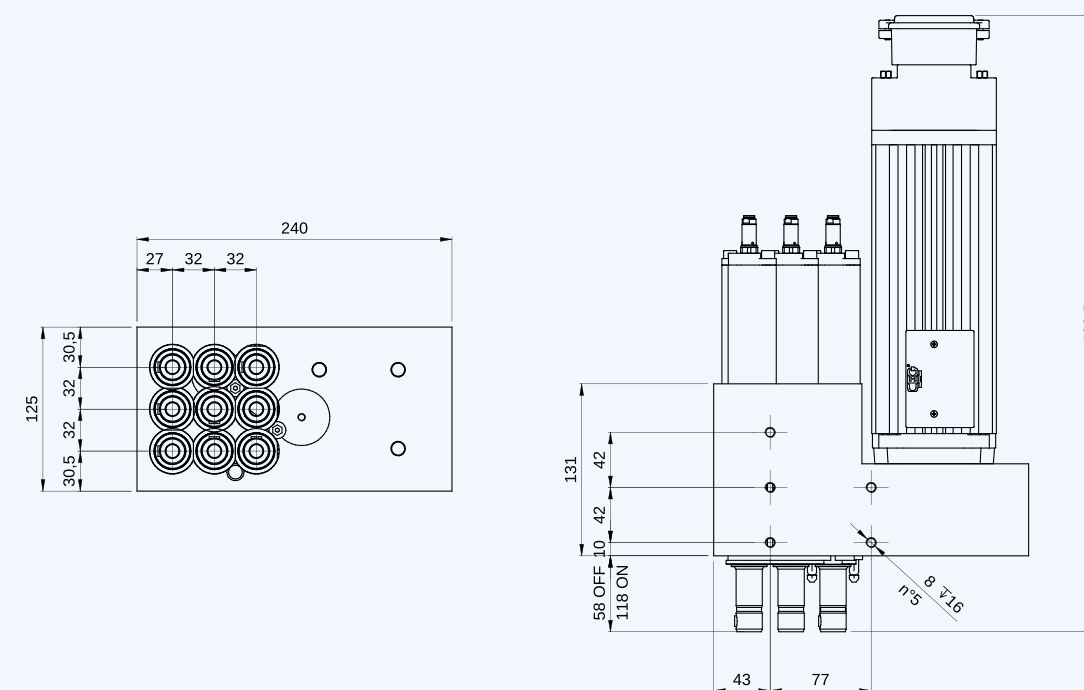

TF.L.14V.4H.OB.A

SPECIFICHE TECNICHE
TECHNICAL SPECIFICATIONS

Attacco punta Tool connection	10 H7 mm
Interasse punte Distance between centers	32 mm
Max lunghezza punta Max boring bits lenght	70 mm
Corsa mandrini verticali Vertical spindles stroke	60 mm
Corsa mandrini orizzontali Horizontal spindles stroke	75 mm
Potenza motore Motor power	1,7 kW
Max rotazione verticali Max vertical spindles stroke	8.000 RPM
Max rotazione orizzontali Max horizontal spindles speed	8.000 RPM
Peso Weight	70 kg

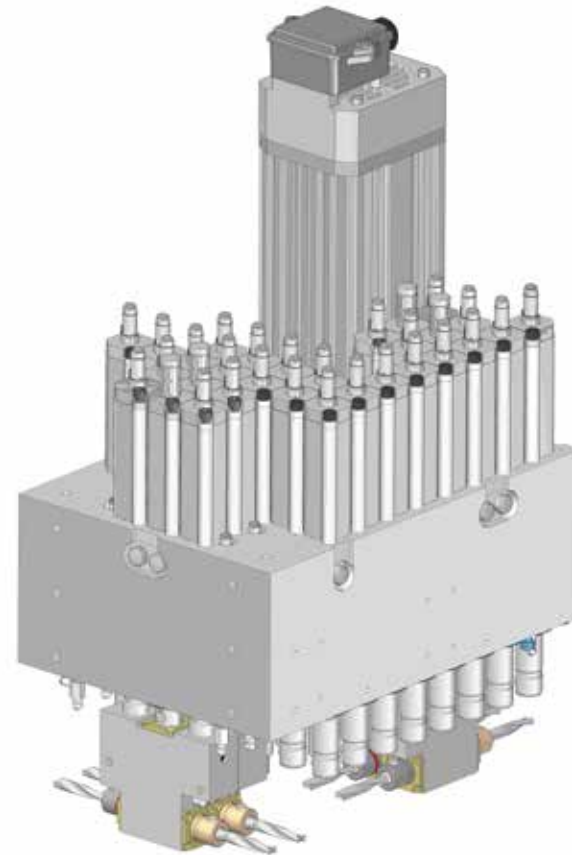

LAYOUT

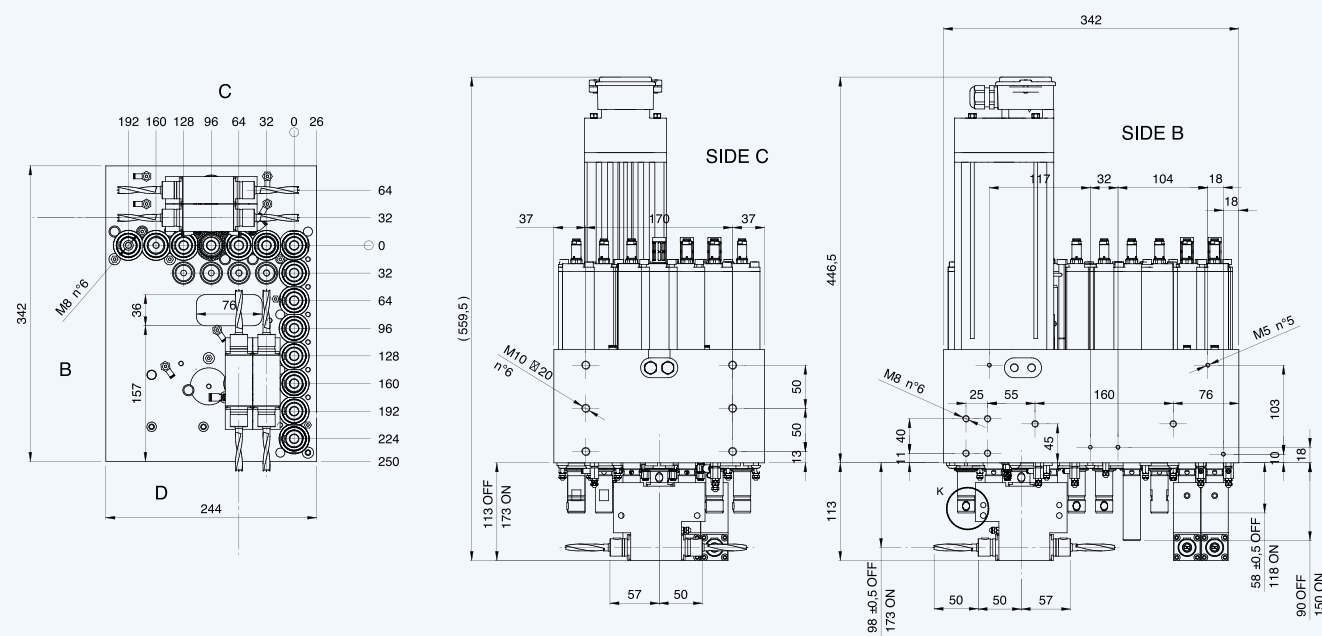

CONFIGURAZIONE A
A CONFIGURATION

TF.A_V.0H.0B

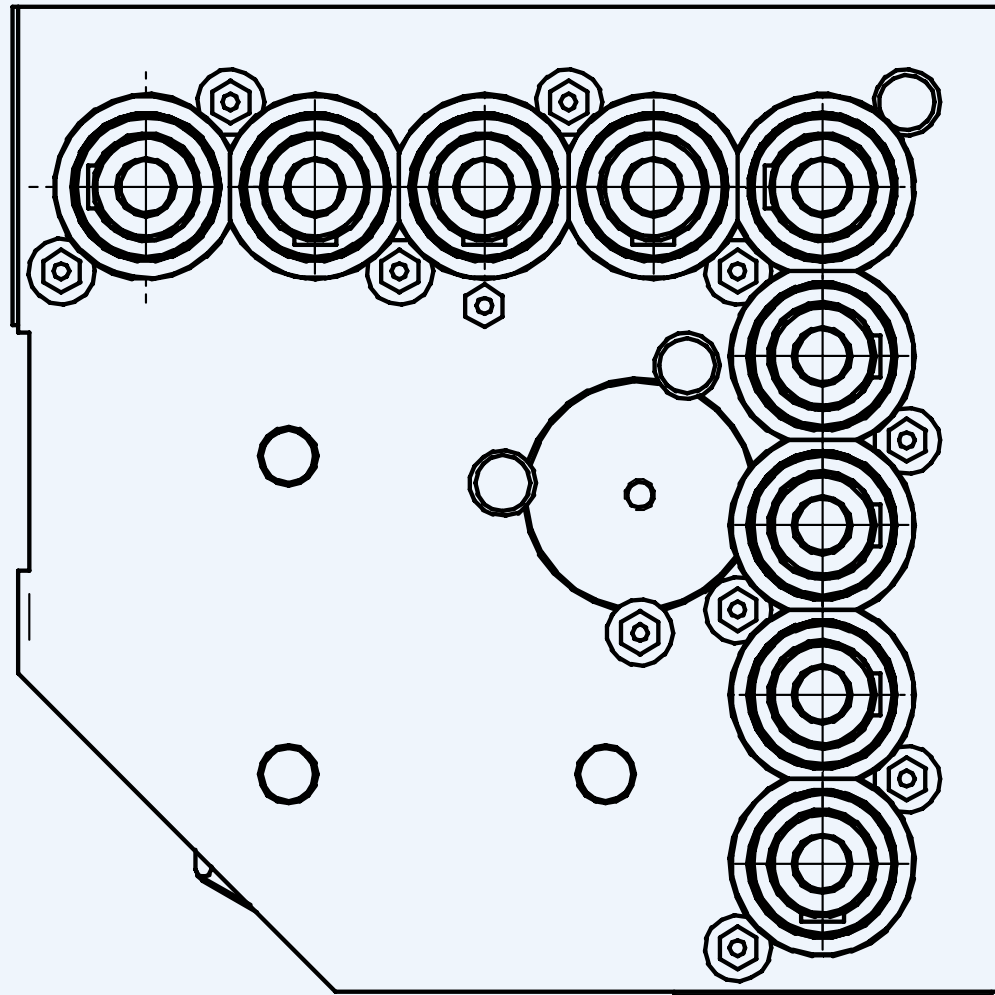

V: Vertical spindle

BORING UNIT IDENTIFICATION KEY

Model	Body Type	Vertical spindles	Horizontal spindles	Blade
TF	A	0	0

CONFIGURAZIONE B
B CONFIGURATION

TF.B_V_H_B

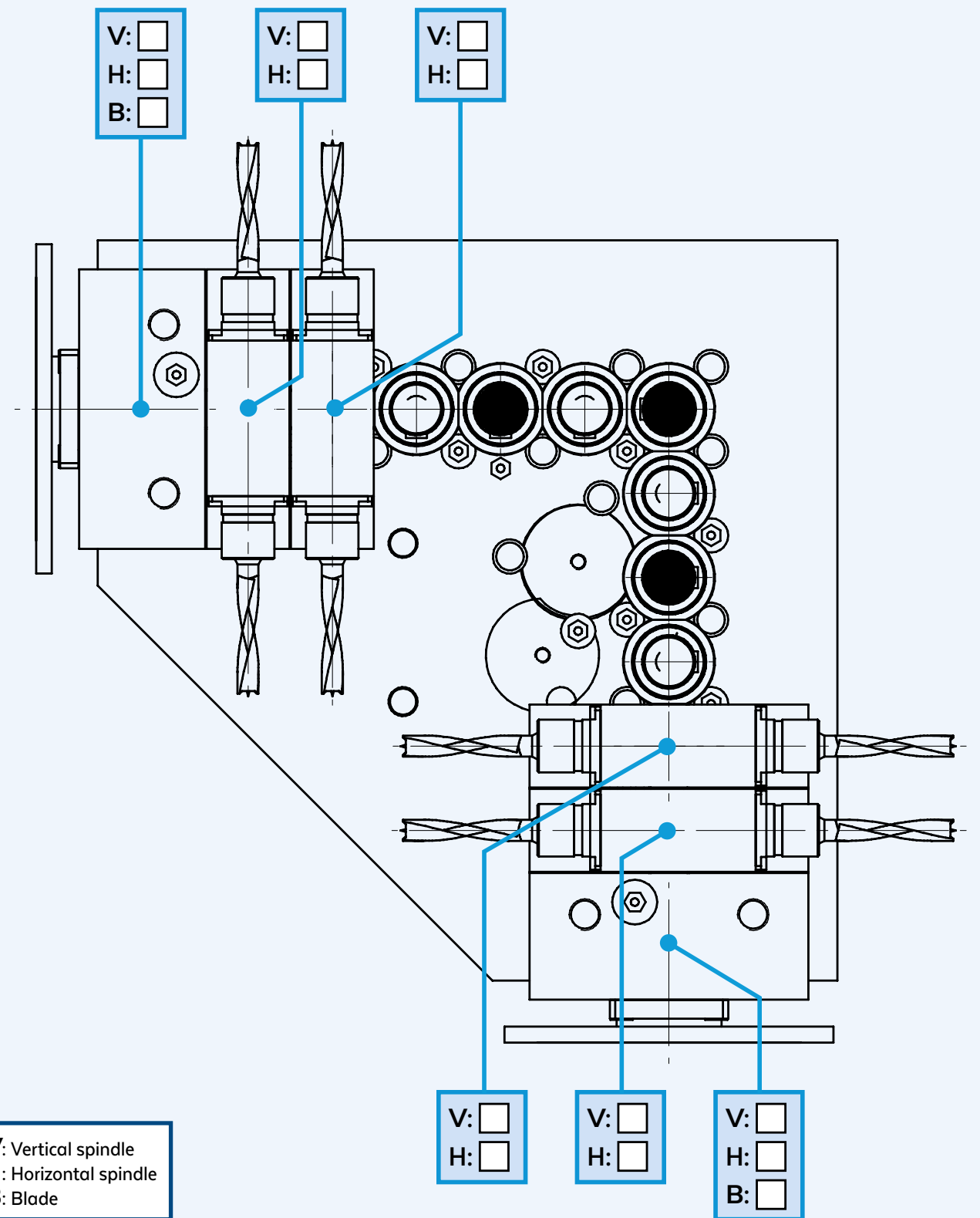

V: Vertical spindle
H: Horizontal spindle
B: Blade

BORING UNIT IDENTIFICATION KEY

Model	Body Type	Vertical spindles	Horizontal spindles	Blade
TF	B

CONFIGURAZIONE C
C CONFIGURATION

TF.C._V._H._B

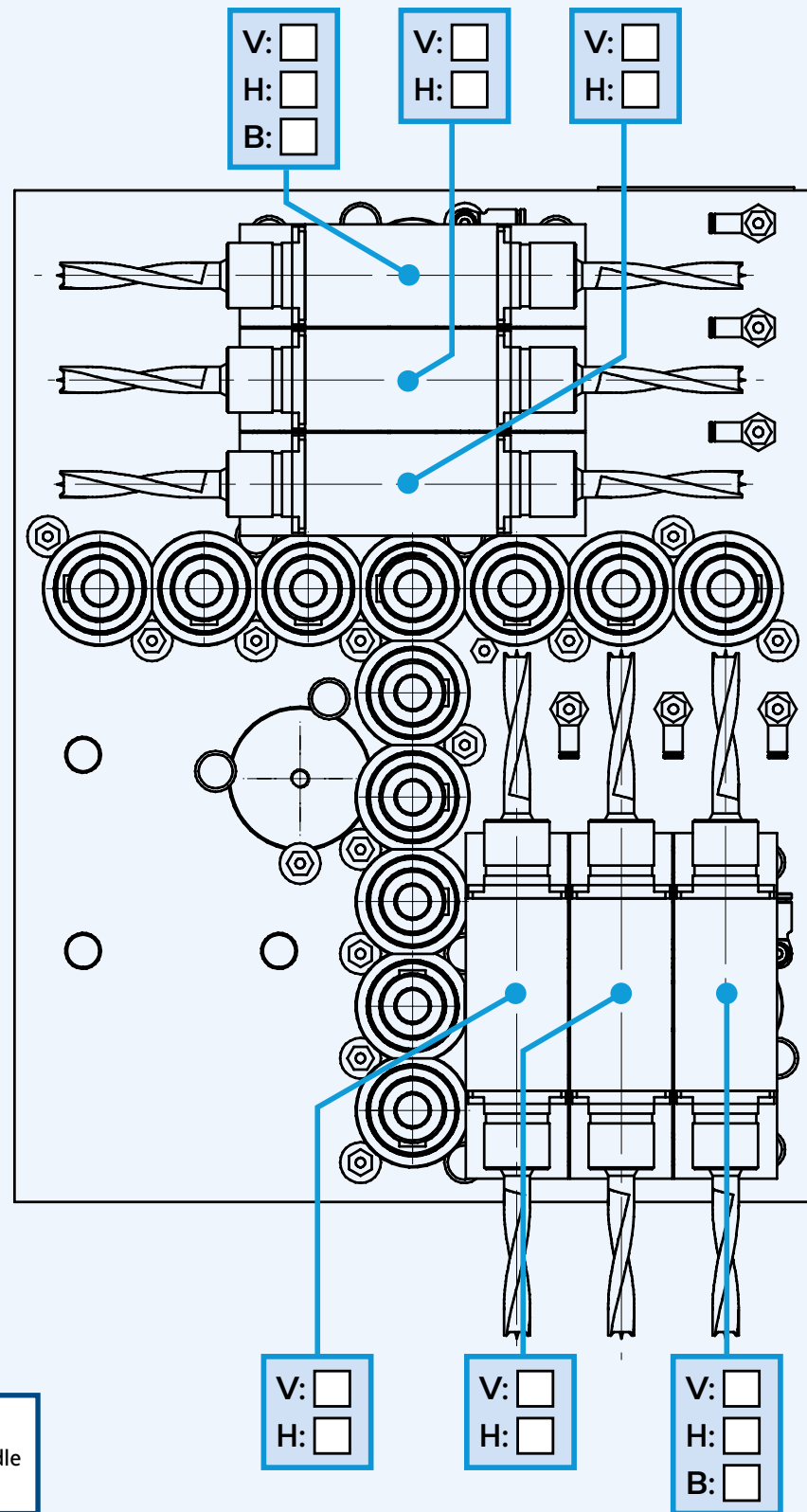

V: Vertical spindle
H: Horizontal spindle
B: Blade

BORING UNIT IDENTIFICATION KEY

Model	Body Type	Vertical spindles	Horizontal spindles	Blade
TF	C

CONFIGURAZIONE D
D CONFIGURATION

TF.D._V._H._B

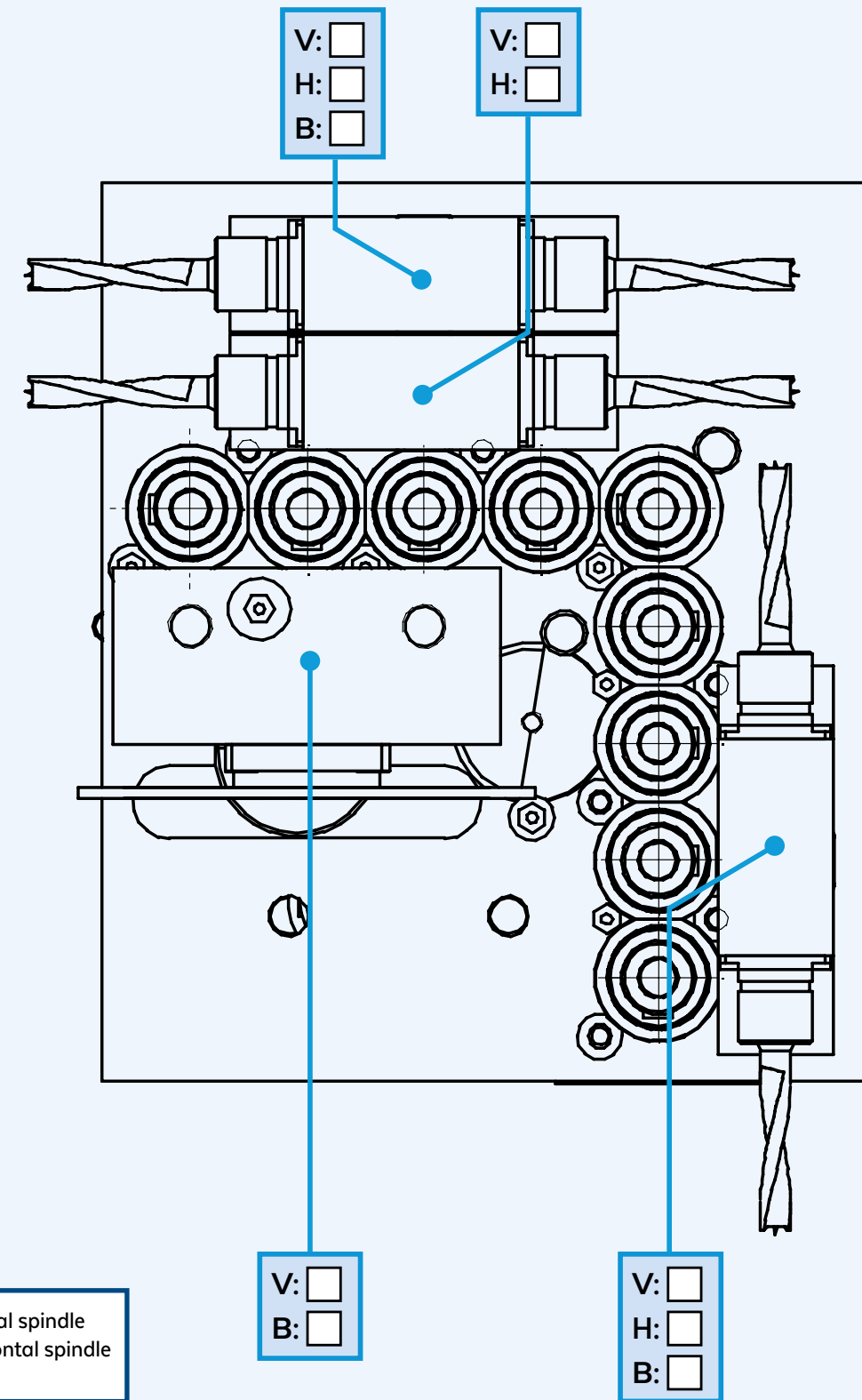

V: Vertical spindle
H: Horizontal spindle
B: Blade

BORING UNIT IDENTIFICATION KEY

Model	Body Type	Vertical spindles	Horizontal spindles	Blade
TF	D

ITM UNITEC GmbH
Kuchengrund 19
71522 Backnang

Tel. +49 7191 495 265-0
Fax +49 7191 495 265 10
info@itm-unitec.com
www.itm-unitec.com

